



Land Use Services Department

# Minneola Solar Project Appeal

Appellant: Newberry Springs Community Services District

Mark Wardlaw, Director  
Land Use Services Department  
August 20, 2024

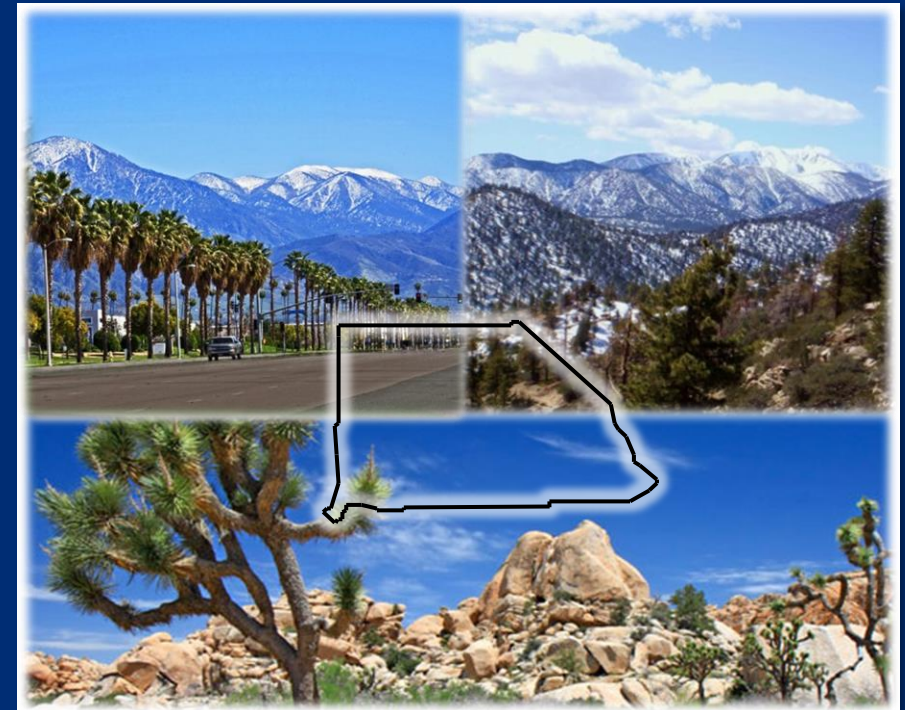

The BMT Minneola Solar Project (Project) is a proposed community-oriented solar facility in the Daggett area, located adjacent to the Barstow-Daggett Airport.

The Project was reviewed and approved by the Planning Commission (Commission) on May 9, 2024, and consists of the following actions:

- Tentative Parcel Map (TPM) to subdivide 91.9 acres into two parcels:
  - Parcel 1 – 62.6 acres (remain vacant and unimproved).
  - Parcel 2 – 27.2 acres.
- Conditional Use Permit (CUP) to develop a 3-megawatt solar facility on Parcel 2.

The Commission action is being appealed by the Newberry Springs Community Services District.

# Project Location Map

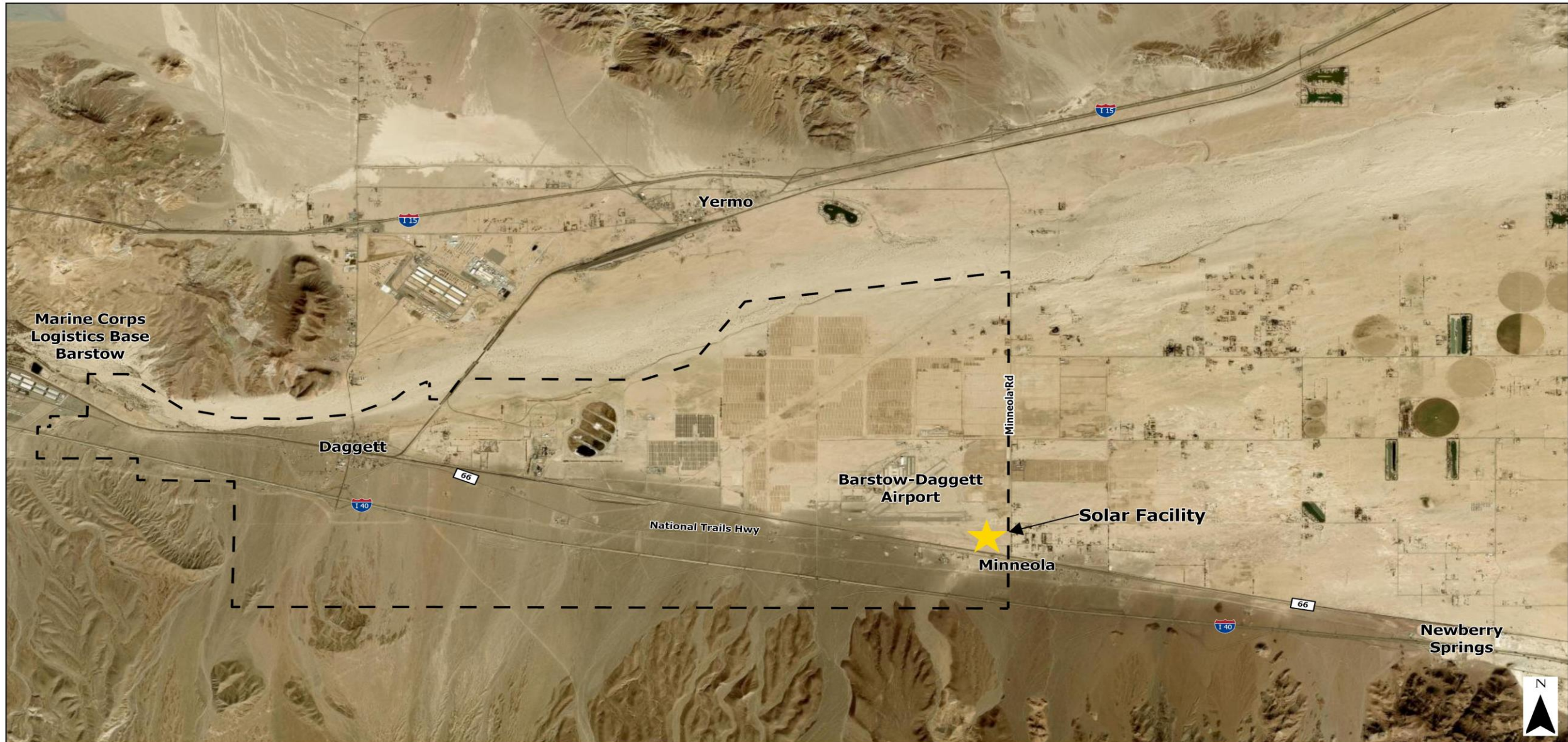

Marine Corps  
Logistics Base  
Barstow

Yermo

Daggett

Barstow-Daggett  
Airport

Solar Facility

Minneola

Newberry  
Springs



# Land Use Category Map

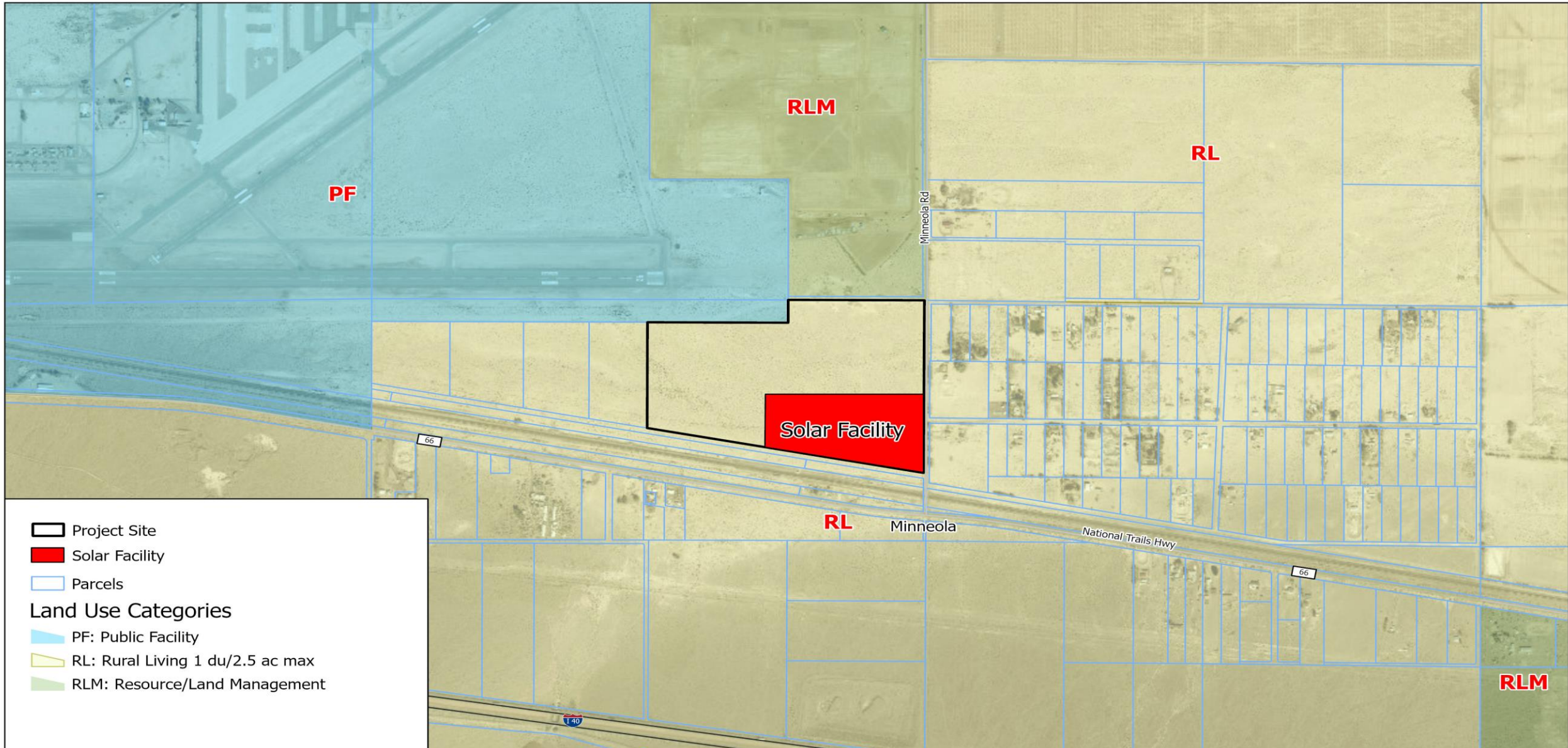

# Land Use Zoning Map

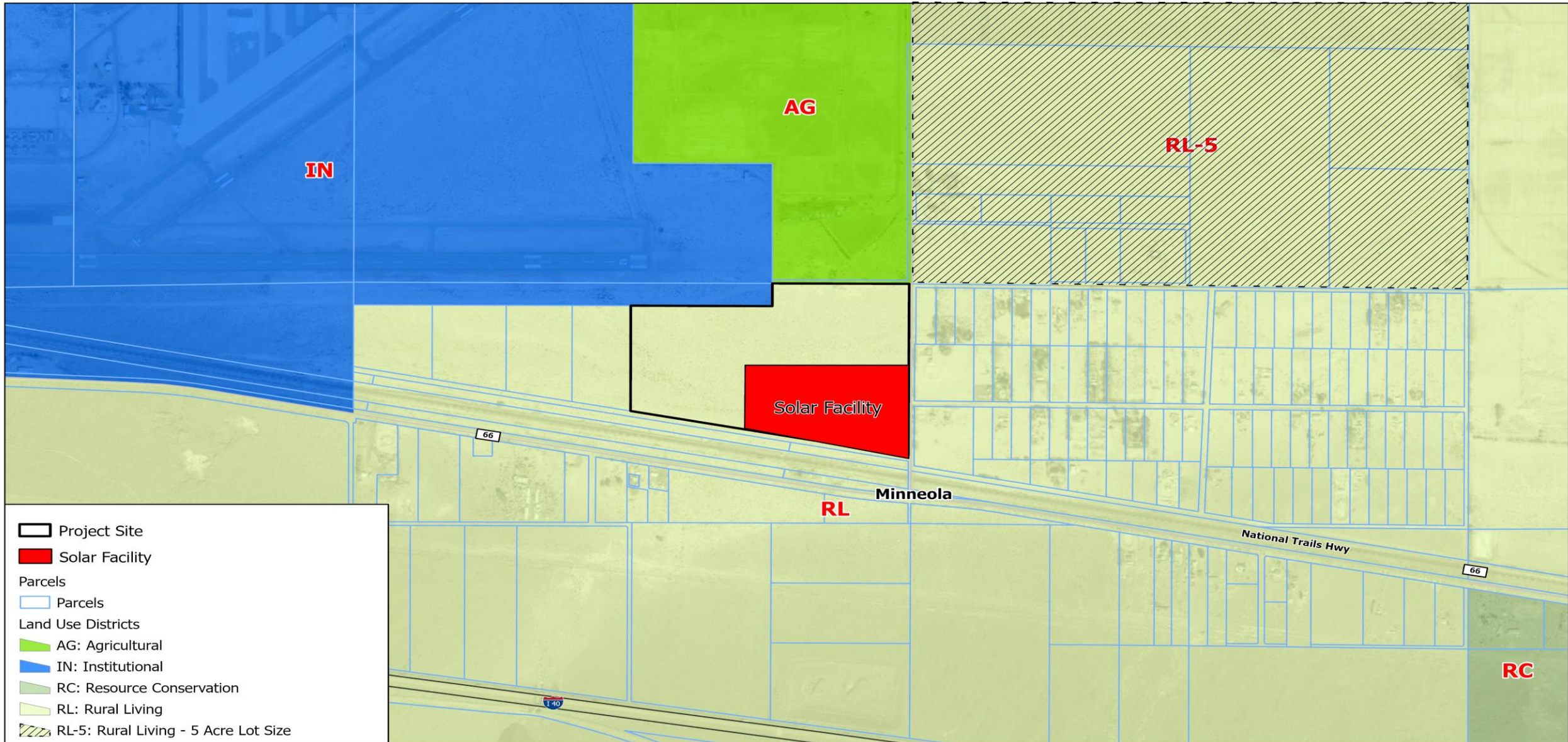

# Solar Projects in the Vicinity

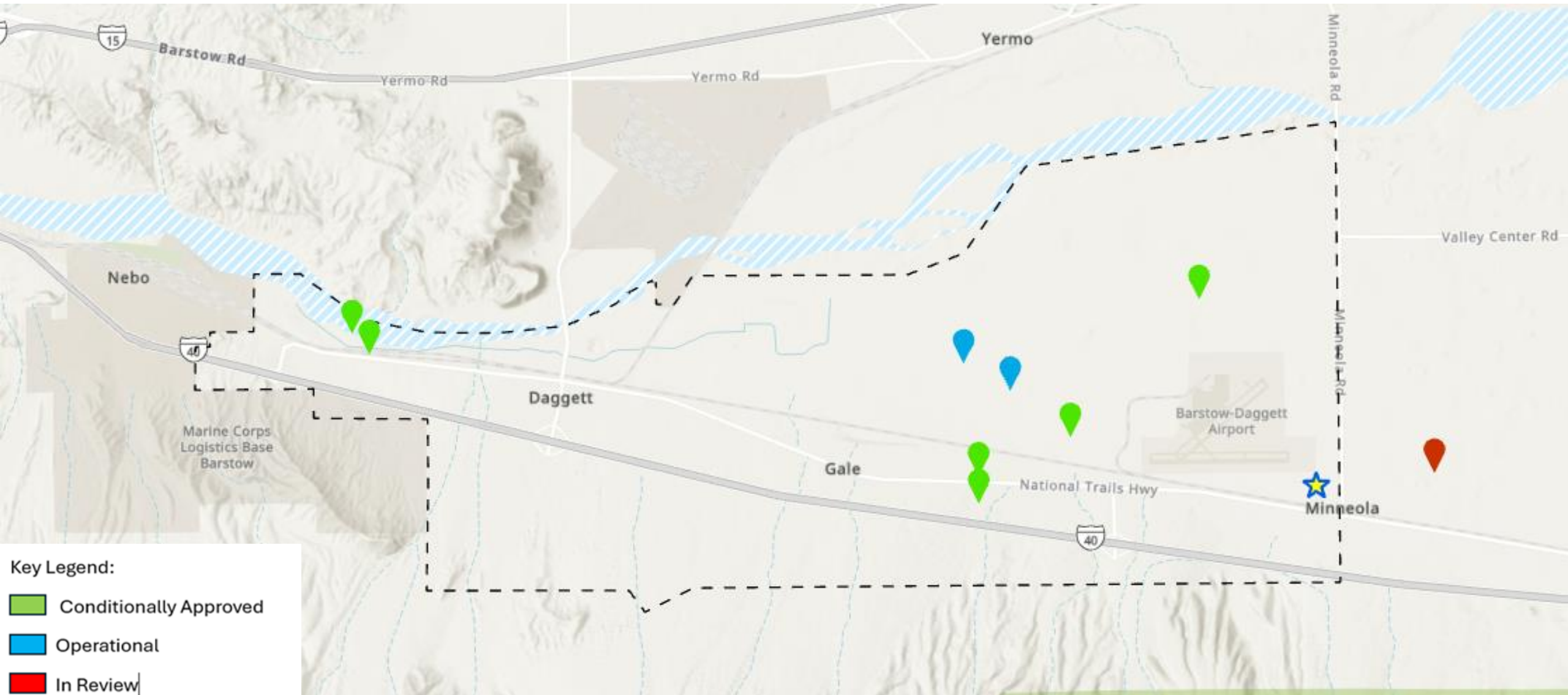

# Site Plan and Parcel Map

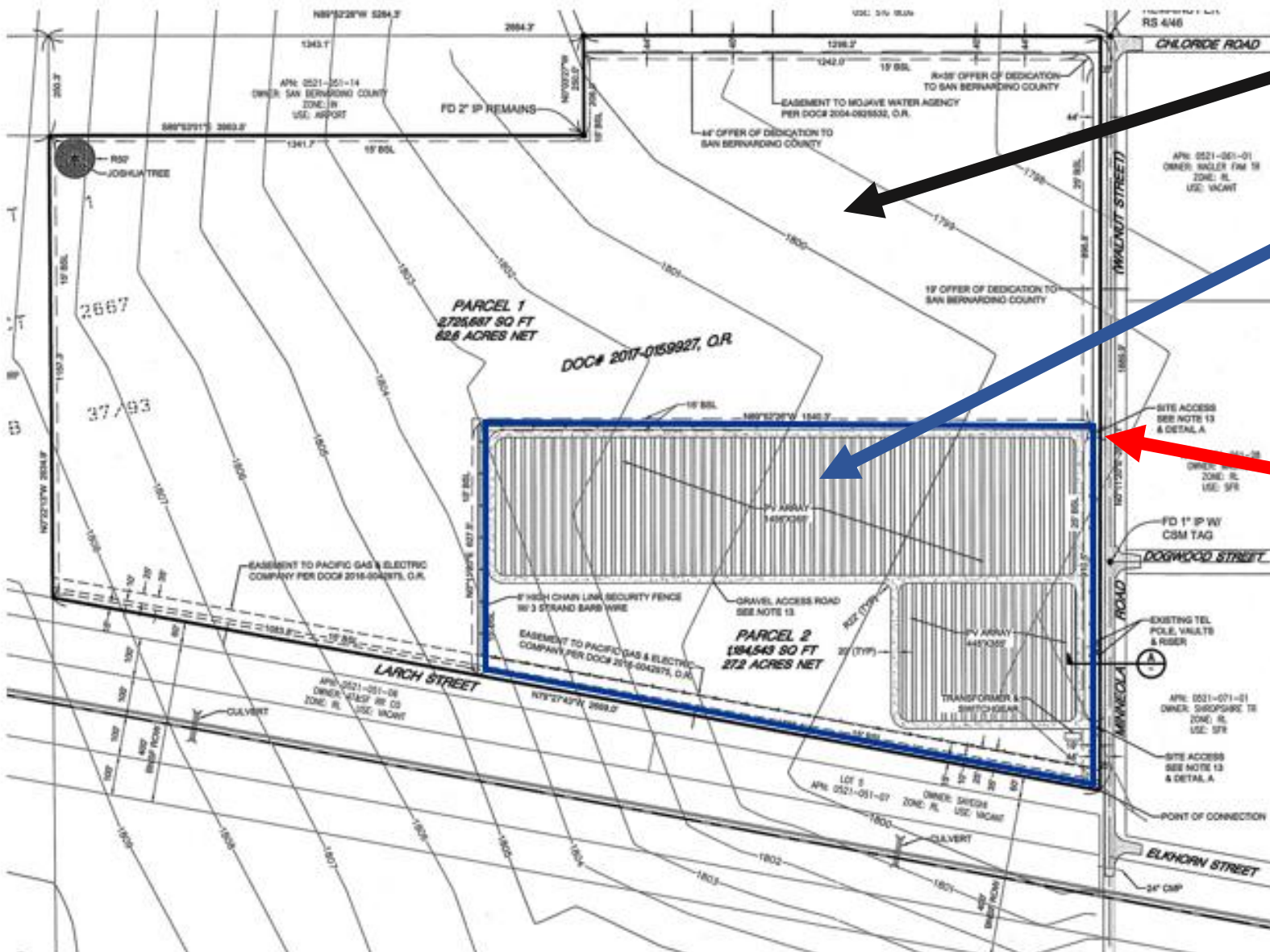

- Parcel 1 (62.6 acres) is to remain vacant.
- Parcel 2 (27.2 acres) is to contain the solar facility comprised of 15,000 solar panels.
- Site access to the solar facility is from Minneola Road.
- The Project is consistent with Development Code requirements.

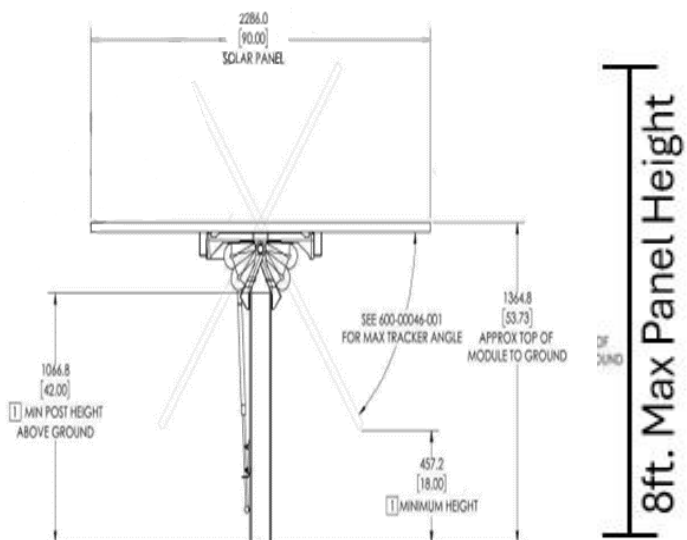

Eight-foot-high tubular steel fencing with slats along the eastern boundary is required.







Looking Northwest from the corner of Minneola Rd. and National Trails Hwy.

## Existing Site Conditions



Looking South from Chloride Road



Looking West from Minneola Road

The Project was determined to be consistent with the Countywide Policy Plan:

## **Community-Oriented solar facility:**

- Up to 60 acres in size.
- Up to 10-megawatt power generation.

## **Daggett Community Action Guide:**

- The Daggett Community Action Guide identifies in the Values Statement, that Daggett residents value its people and heritage, quality education, and its relationship with the military.

## **Renewable Energy (RE) & Conservation Element Policies:**

- Policy RE-4.7: Site selection and site design shall be guided by priorities relative to habitat conservation and mitigation.
- Policy RE-5.1.1: Community-oriented RE generation facility sites may be less disturbed or degraded but should contribute direct benefits to the communities they are intended to serve.
- Policy RE-5.1.2: Siting of RE generation facilities will conform to the Development Code.

## **Transportation and Mobility Element (TM):**

- Policy TM-6.4: Airport Land Use Compatibility – We require proposed developments to be consistent with applicable airport master plans and airport safety review areas.

## **Hazards Element (HZ), Environmental Justice Policies:**

- Policy HZ-3.1: Health Risk Assessment – We require an assessment when a Project could potentially increase cancer risk.
- Policy HZ-3.16: Notification – We require notification through the County website and by mail in the predominant language spoken.
- Policy HZ-3.17: Community Stakeholders – We require coordination with stakeholders to increase public awareness on development applications and potential funding opportunities.
- Policy HZ-3.18: Application Requirements – We require applicants to indicate how their Project will address potential environmental justice concerns.

# Environmental Justice Focus Area (EJFA)



 = EJ Focus Area

The Initial Study/Mitigated Negative Declaration (IS/MND) prepared and circulated for CEQA-mandated 30-day public review and comment period found the following as less than significant impact and no mitigation is required for:

- Air Quality
- Geology and Soils
- Greenhouse Gas Emissions
- Hazards and Hazardous Materials

The Mitigation Monitoring and Reporting Program includes measures to reduce the potential impacts to a level below significance for the following:

- Biological Resources
- Cultural Resources
- Tribal Resources

Standard conditions of approval are imposed on the Project, as well as mitigation measures identified in the IS/MND document, to reduce potential impacts to levels less than significant, including:

- Compliance with Regulation 403, Fugitive Dust Control, as adopted by the Mojave Desert Air Quality Management District.
- Valley Fever Management Plan.
- Pre-Construction nesting bird surveys and biological surveys.
- Mitigation to protect Desert Tortoises.
- Oversight by archaeologist for potential cultural resources and tribal cultural resources.
- Installation of eight-foot-high fencing with slats along easterly property boundary for screening purposes.
- Avigation Easement.

## **Project Notice/Notice of Hearing**

- Public notifications for the Project comply with Section 85.03.080 of the Development Code, and EJFA policies.
- Public Hearing Notices were sent to surrounding properties within 700 feet of the project boundaries.
- Staff received 21 e-mails of concern related to the amount of dust circulated during construction and the ongoing dust resulting from disturbed soil.

## **CEQA Public Comments**

- A Notice of Availability/Notice of Intent to adopt a MND was advertised and distributed for a 30-day public comment period, which concluded on December 18, 2023.
- Staff received six environmental comments during the public comment period relating to federal species of concern, potential impacts to air quality, health, viewsheds, and public safety.



The Project site is located within the Safety Review Area 3 of the Barstow-Daggett Airport.

Pursuant to the County Code, two members of the County Airports Commission augmented the Planning Commission to serve as the Airport Land Use Commission on this matter.

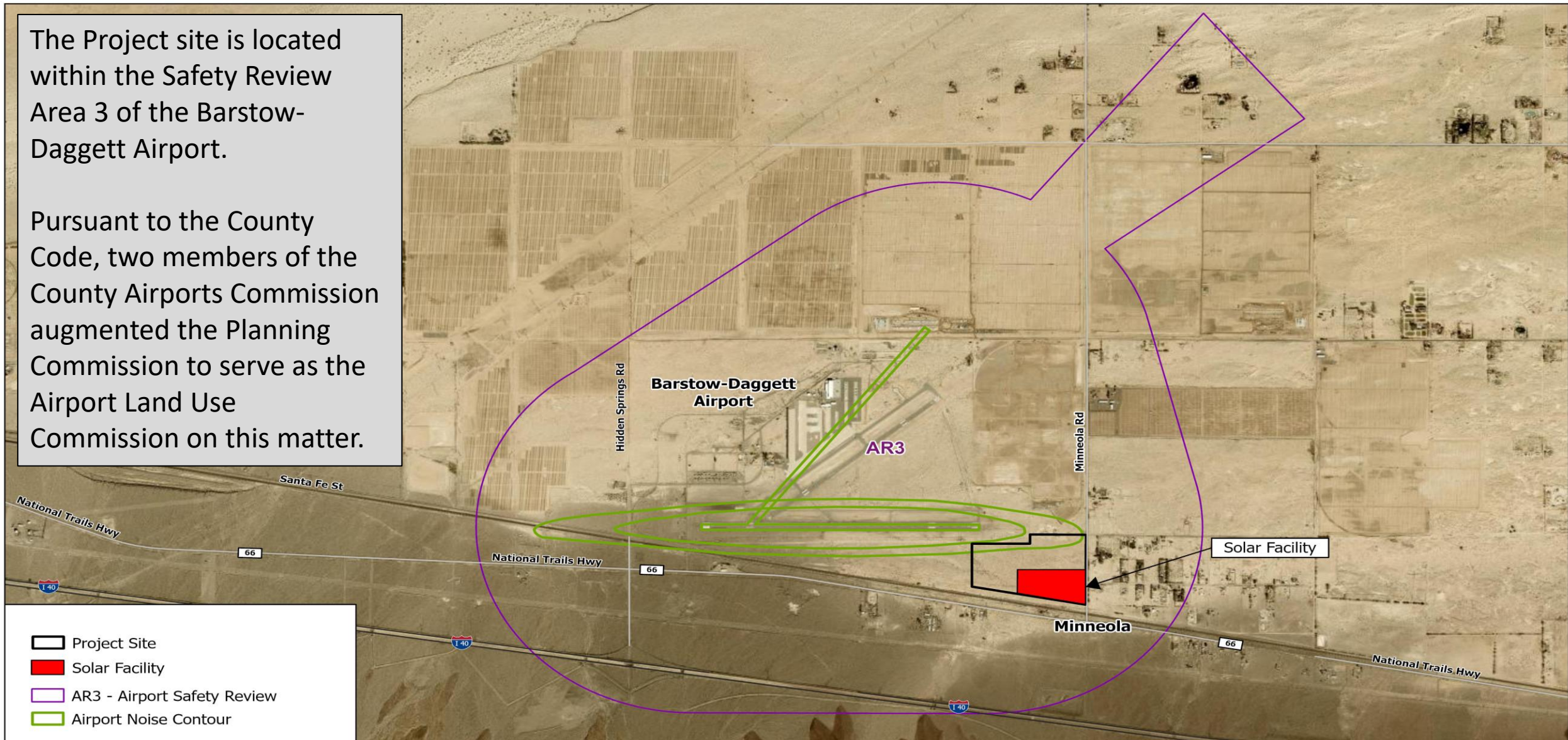

- Project Site
- Solar Facility
- AR3 - Airport Safety Review
- Airport Noise Contour

The Commission, augmented with two members of the County Airports Commission, conducted a public hearing on May 9, 2024, to consider the Project.

- One member from the public provided comments pertaining to microscopic silica and environmental justice policy concerns.
- The Project has been designed to be consistent with the Countywide Plan and Development Code for the approval of the TPM and CUP.
- With a vote of 5-0-2, with two Commissioners absent, the Commission approved the Project as proposed, including the TPM, CUP, Project Findings, MND, and the Mitigation Monitoring and Reporting Program.

On May 17, 2024, the Newberry Springs Community Services District filed a timely appeal of the Commission's action on the Project. The primary appeal points are as follows:

- Request to incorporate by reference prior opposition to this Project as well as another project.
- The Project would disturb the soil and generate hazardous silica dust.
- County has a fiduciary duty to protect residents.

The Appellant requests incorporation by reference of all written and oral testimony previously submitted regarding the Project as well as that for another project, the Daggett Solar project by Clearway Energy.

## **Response to Issue:**

- The request is generalized and does not identify specific documents and/or arguments relevant to the appeal.
- The appeal does not clarify how the County violated its obligations under CEQA for purposes of the Project.
- Without specifics, staff is unable to identify the comments that concern the Appellant. However, staff has included responses to comments to the MND for consideration by the Board of Supervisors (Board).

The Appellant asserts that the Project would expose residents to additional hazardous silica dust. The Appellant claims that the soil disturbance and emissions of carcinogenic silica dust directly violates California Environmental Justice laws. The Appellant also asserts social and economic concerns, and other negative impacts.

## **Response to Issue:**

- Potential risks related to air quality and health were analyzed in the Project’s MND. The analysis included mitigation to minimize potential risk during construction and concluded that operations would not result in any tangible effects.
- Social and economic concerns do not fall under CEQA. CEQA evaluates physical changes to the environment. In addition, Environmental Justice concerns are incorporated into the County’s review of the Project pursuant to the Government Code.
- Regarding other areas of concern, the MND analyzed potential impacts to Aesthetics, Biological Resources, Population and Housing and included mitigation measures, as appropriate.

The Appellant asserts that the Board has a fiduciary duty to protect County residents.

## **Response to Issue:**

- The Appellant's concern is generalized and does not identify any specifics relating to the Project.
- The Project has been processed and reviewed for compliance with the Countywide Plan and Development Code.
- The Project is located within an EJFA and County policies pertaining to EJFA were observed.
- The entitlement process is publicly noticed and has allowed for opportunities for stakeholders and community members to participate in the process.

1. Deny the Appeal.
2. Adopt the Mitigated Negative Declaration and Mitigation Monitoring and Reporting Program.
3. Adopt the Findings for approval of the BMT Minneola Solar Project.
4. Approve Tentative Parcel Map No. 20538 to subdivide approximately 91 acres into two parcels and a Conditional Use Permit to construct and operate a 3-megawatt community-oriented solar array facility on approximately 28 acres, subject to the Conditions of Approval.
5. Direct Staff to file the Notice of Determination in accordance with the California Environmental Quality Act.