

- B. THE OUTSIDE DIAMETER OF THE LATERAL MUST BE LESS THAN OR EQUAL TO 1/2 THE INSIDE DIAMETER OF THE MAIN LINE. IF THE UPSTREAM AND DOWNSTREAM DIAMETERS OF THE MANHOLE ARE NOT THE SAME, THE GOVERNING INSIDE DIAMETER OF THE MAIN LINE SHALL BE CONSIDERED TO BE THAT WHERE THE EXTENDED CENTERLINE OF THE LATERAL ENTERS THE MANHOLE.
- C. IN NO INSTANCE SHALL THE INSIDE DIAMETER OF THE LATERAL TO THE MANHOLE BE GREATER THAN 30" (750 mm).

- 13. MANHOLE FRAME AND COVER SHALL CONFORM TO SPPWC 633 UNLESS OTHERWISE SHOWN.
- 14. MANHOLE SHAFT SHALL CONFORM TO SPPWC 324 UNLESS OTHERWISE SHOWN.
- 15. WHERE A MANHOLE SHAFT - 36" (900 mm) WITHOUT REDUCER IS SPECIFIED REFER TO SPPWC 326.
- 16. WHERE A PRESSURE MANHOLE SHAFT - WITH ECCENTRIC REDUCER IS SPECIFIED REFER TO SPPWC 328.
- 17. WHERE A PRESSURE MANHOLE SHAFT - 914 mm (36") WITHOUT REDUCER IS SPECIFIED REFER TO SPPWC 329.
- 18. THE FOLLOWING SPPWC ARE INCORPORATED HEREIN:
 - 324 MANHOLE SHAFT - WITH ECCENTRIC REDUCER
 - 326 MANHOLE SHAFT - 36" (900 mm) WITHOUT REDUCER
 - 328 PRESSURE MANHOLE SHAFT - WITH ECCENTRIC
 - 329 PRESSURE MANHOLE SHAFT 36" (914 mm) WITHOUT REDUCER
 - 630 24" (610 mm) MANHOLE FRAME AND COVER
 - 633 36" (914 mm) MANHOLE FRAME AND COVER
 - 635 STEEL STEP
 - 636 POLYPROPYLENE PLASTIC STEP

NOT FOR BID

STANDARD PLANS FOR PUBLIC WORKS CONSTRUCTION	STANDARD PLAN
MANHOLE PIPE-TO-PIPE	320-2
MAIN LINE ID = 36" (900 mm) OR LARGER	SHEET 4 OF 4

(Modified)

SIZE AND SPACING OF STEEL AS SHOWN ON PROJECT DRAWINGS, EXCEPT THAT 5 BARS ON EACH SIDE OF SHAFT SHALL BE NOT SMALLER THAN #5 @ 4" (#16M @ 100 mm) OC OR EQUIVALENT

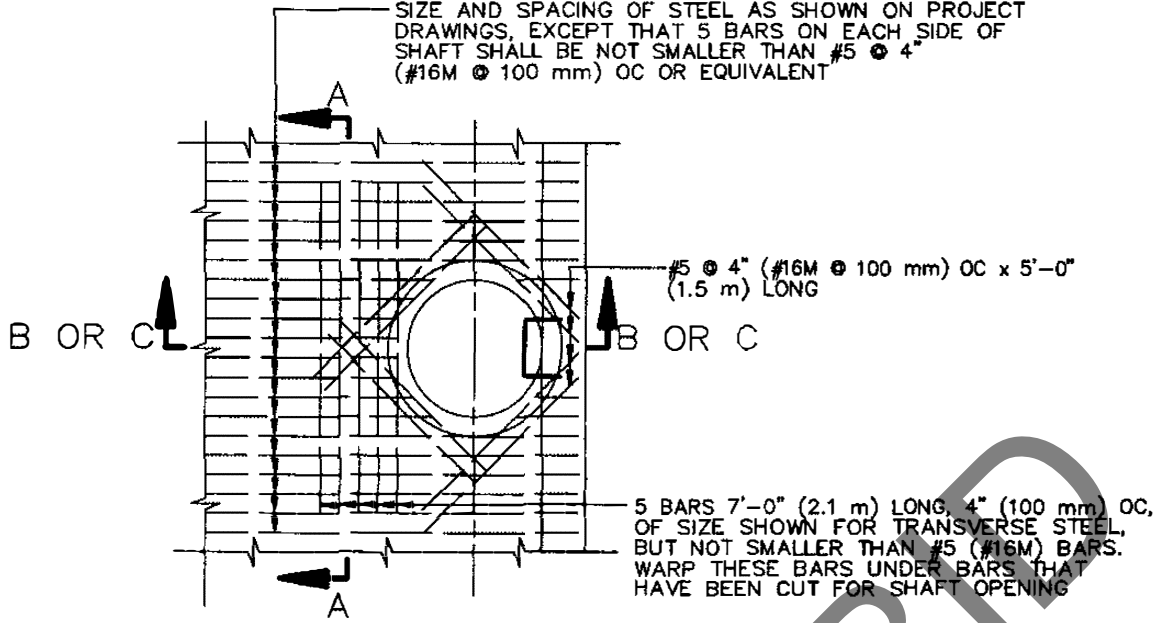

PLAN

(SHAFT NOT SHOWN)

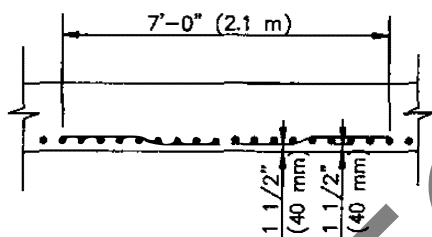

SECTION A - A

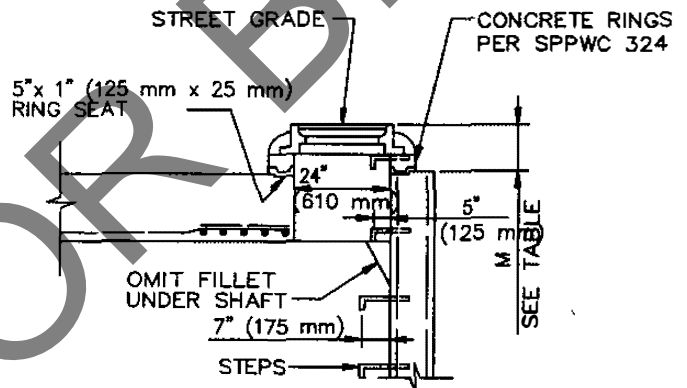

SECTION C - C

SEE NOTE 1

MANHOLE FRAME AND COVER PER SPPWC 633

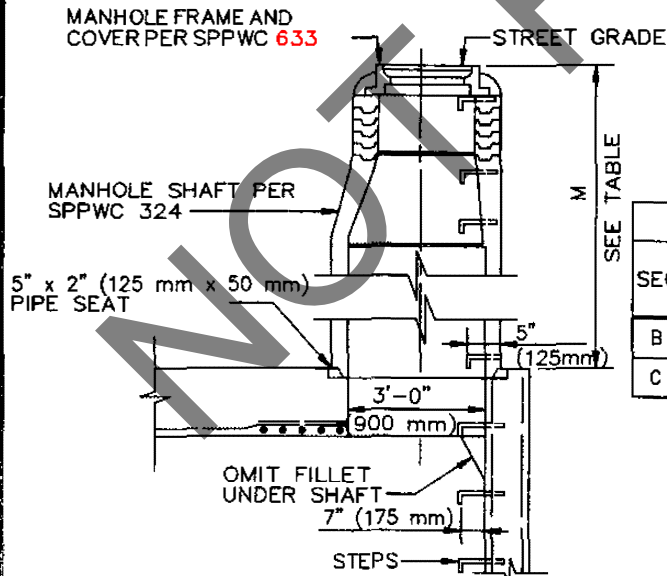

SECTION B - B

TABLE OF VALUES FOR M (SEE NOTE 1)

SECTION	PAVED STREET		UNPAVED STREET	
	MAX	MIN	MAX	MIN
B - B	-	2'-10 1/2" (867 mm)	-	3'-6" (1060 mm)
C - C	11" (282 mm)	8 1/2" (217 mm)	16" (410 mm)	15" (380 mm)

STANDARD PLANS FOR PUBLIC WORKS CONSTRUCTION

PROMULGATED BY THE PUBLIC WORKS STANDARDS INC. GREENBOOK COMMITTEE 1992 REV. 1996, 2009

MANHOLE - CONCRETE BOX STORM DRAIN

STANDARD PLAN

323-2

USE WITH STANDARD SPECIFICATIONS FOR PUBLIC WORKS CONSTRUCTION

SHEET 1 OF 2

(Modified)

NOTES

1. WHEN DEPTH M FROM STREET GRADE TO THE TOP OF THE BOX IS LESS THAN 2'-10 1/2" (867 mm) FOR PAVED STREETS OR 3'-6" (1060 mm) FOR UNPAVED STREETS, CONSTRUCT SHAFT PER SECTION C-C.
2. STATIONS OF MANHOLES SHOWN ON PLANS. APPLY AT CENTERLINE LINE OF SHAFT. ELEVATIONS ARE SHOWN AT CENTERLINE OF SHAFT.
3. REINFORCEMENT SHALL CONFORM TO ASTM A 615, GRADE 40 (ASTM A 615M, GRADE 300), AND SHALL TERMINATE 40 mm (1 1/2") CLEAR OF CONCRETE SURFACES UNLESS OTHERWISE SHOWN.
4. STEPS SHALL CONFORM TO SPPWC 635 OR 636. UNLESS OTHERWISE SHOWN, STEPS SHALL BE UNIFORMLY SPACED 14" (350 mm) TO 15" (375 mm) OC. THE LOWEST STEP SHALL NOT BE MORE THAN 24" (600 mm) ABOVE THE INVERT.
5. MANHOLE FRAME AND COVER SHALL CONFORM TO SPPWC 633 UNLESS OTHERWISE SHOWN.
6. MANHOLE SHAFT SHALL CONFORM TO SPPWC 324 UNLESS OTHERWISE SHOWN.
7. WHERE A MANHOLE SHAFT - 36" (900 mm) WITHOUT REDUCER IS SPECIFIED REFER TO SPPWC 326.
8. WHERE A PRESSURE MANHOLE SHAFT - WITH ECCENTRIC REDUCER IS SPECIFIED REFER TO SPPWC 328.
9. WHERE A PRESSURE MANHOLE SHAFT - 36" (900 mm) WITHOUT REDUCER IS SPECIFIED REFER TO SPPWC 329.
10. THE FOLLOWING SPPWC ARE INCORPORATED HEREIN:
 - 324 MANHOLE SHAFT - WITH ECCENTRIC REDUCER
 - 326 MANHOLE SHAFT - 36" (900 mm) WITHOUT REDUCER
 - 328 PRESSURE MANHOLE SHAFT - WITH ECCENTRIC
 - 329 PRESSURE MANHOLE SHAFT - 36" (900 mm) WITHOUT REDUCER
 - 630 24" (600 mm) MANHOLE FRAME AND COVER
 - 633 36" (900 mm) MANHOLE FRAME AND COVER
 - 635 STEEL STEP
 - 636 POLYPROPYLENE PLASTIC STEP

STANDARD PLANS FOR PUBLIC WORKS CONSTRUCTION

**MANHOLE - CONCRETE
BOX STORM DRAIN**

STANDARD PLAN

323-2

SHEET 2 OF 2

(Modified)

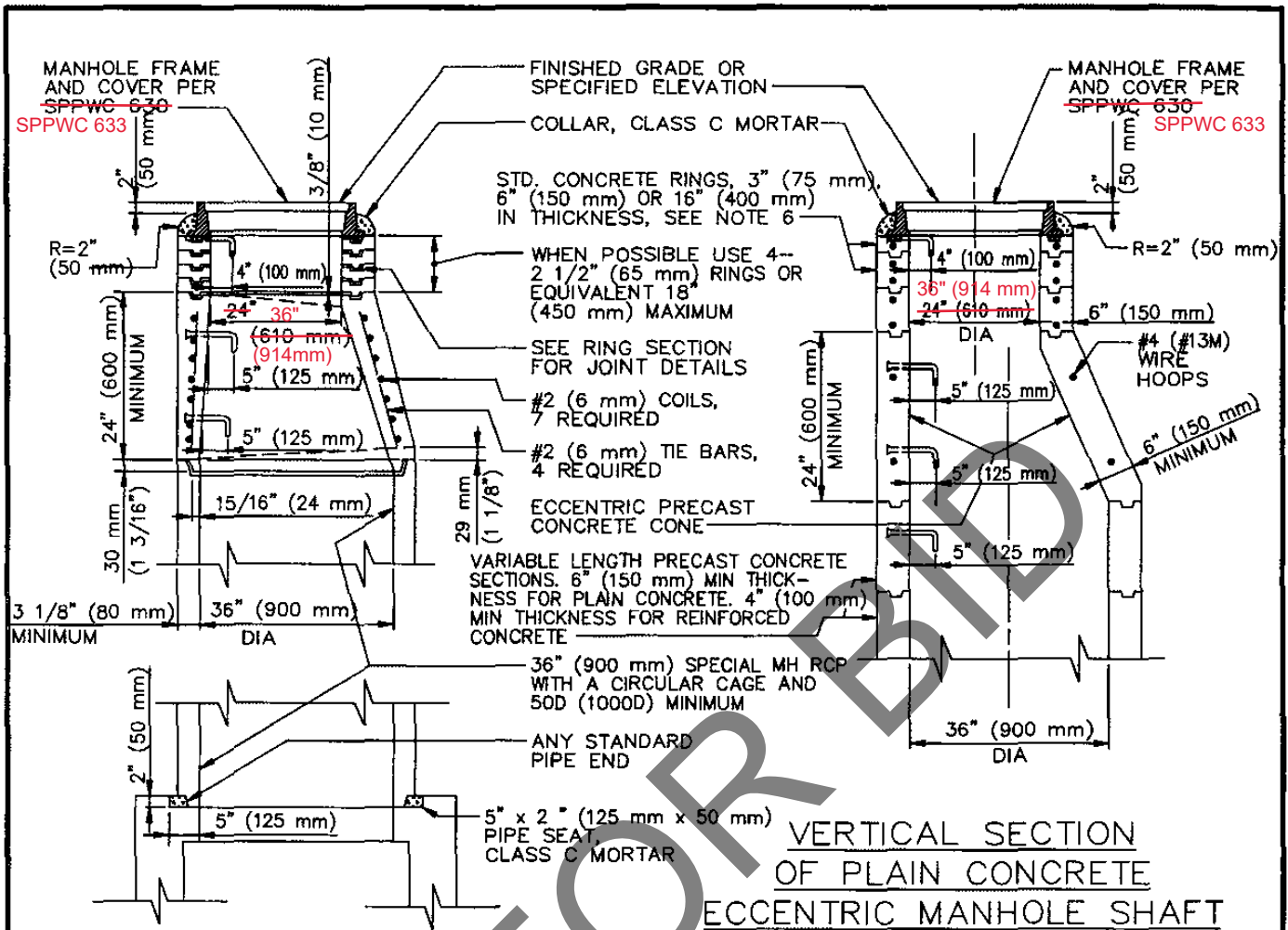

VERTICAL SECTION OF REINFORCED CONCRETE ECCENTRIC MANHOLE SHAFT

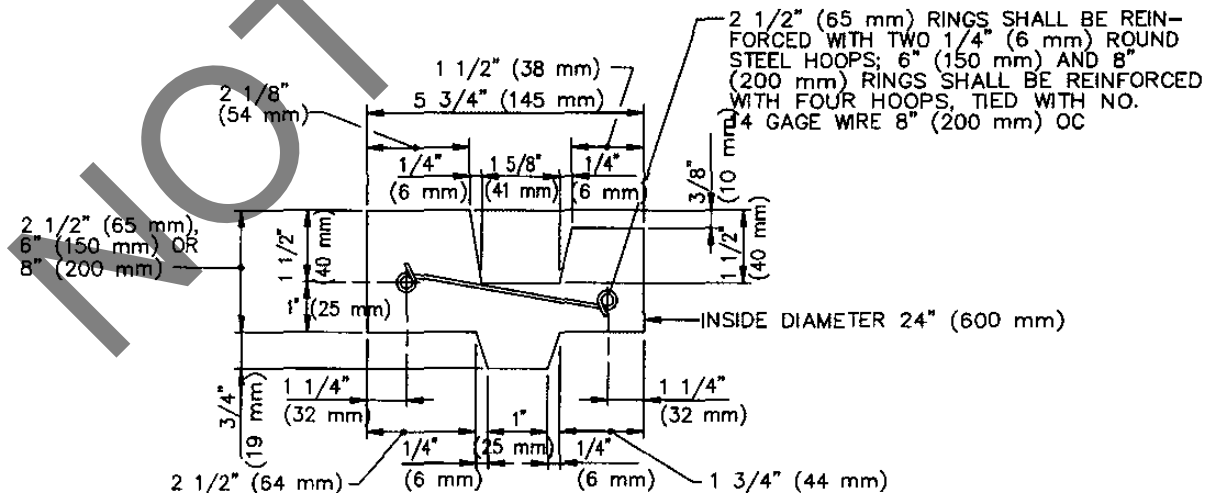

STANDARD PLANS FOR PUBLIC WORKS CONSTRUCTION		
PROMULGATED BY THE PUBLIC WORKS STANDARDS INC. GREENBOOK COMMITTEE 1992 REV. 1996, 2009	MANHOLE SHAFT WITH ECCENTRIC REDUCER	STANDARD PLAN 324-2
USE WITH STANDARD SPECIFICATIONS FOR PUBLIC WORKS CONSTRUCTION		SHEET 1 OF 2

(Modified)

NOTES

1. UNLESS OTHERWISE INDICATED THIS STRUCTURE SHALL CONFORM TO ASTM C 478M (ASTM C 478) AND ALL CONCRETE SHALL BE PER SSPWC 201-1.2.
2. MANHOLE FRAME AND COVER SHALL CONFORM TO SPPWC 633.
3. ALL JOINTS SHALL BE SEALED BY FILLING THE ANNULAR SPACES WITH CLASS C MORTAR. THE INSIDE OF THE SHAFT AT EACH JOINT SHALL BE WIPED CLEAN OF EXCESS MORTAR.
4. PROTECTIVE PLASTIC LINER (T LOCK) OR ENGINEER-APPROVED COATINGS WHERE REQUIRED BY THE PLANS SHALL BE IN ACCORDANCE WITH SSPWC AND THE MANUFACTURER'S DIRECTIONS.
5. STEPS SHALL CONFORM TO SPPWC 635 OR 636. THE TOP STEP SHALL BE PLACED DIRECTLY BENEATH THE MANHOLE FRAME. UNLESS OTHERWISE SHOWN, STEPS SHALL BE UNIFORMLY SPACED 14" (350 mm) TO 15" (375 mm) OC.
6. THE ECCENTRIC MANHOLE SHAFT REDUCER AND RINGS MAY BE PLAIN CONCRETE. FOR PLAIN CONCRETE SECTIONS THE MINIMUM THICKNESS SHALL BE 6" (150 mm).
7. THE PRECAST CONCRETE MANHOLE STRUCTURES WILL BE INSPECTED BY THE ENGINEER WHO WILL INDICATE ACCEPTANCE FOR SHIPMENT TO THE JOB BY MARKING THE STRUCTURES WITH THE AGENCY'S STAMP.
8. THE VERTICAL SIDES OF THE MANHOLE SHAFT AND THE ECCENTRIC REDUCER SHALL BE LOCATED ABOVE AND IN LINE WITH THE SIDE OF THE STORM DRAIN CONDUIT.
9. CONSTRUCT MANHOLE SAFETY LEDGE PER SPPWC 330 IF DEPTH OF MANHOLE TO INVERT IS GREATER THAN 20' (6 m) AND MANHOLE SHAFT IS GREATER THAN 10' (3 m). WHEN SAFETY LEDGE IS REQUIRED AND MANHOLE SHAFT IS LESS THAN 12' (4 m) SPPWC 326 MUST BE USED.
10. THE FOLLOWING SPPWC ARE INCORPORATED HEREIN:

- 633 36" (914mm) MANHOLE FRAME AND COVER
- 635 STEEL STEP
- 636 POLYPROPYLENE PLASTIC STEP

STANDARD PLANS FOR PUBLIC WORKS CONSTRUCTION

**MANHOLE SHAFT WITH
ECCENTRIC REDUCER**

STANDARD PLAN
METRIC

324-2

SHEET 2 OF 2

(Modified)

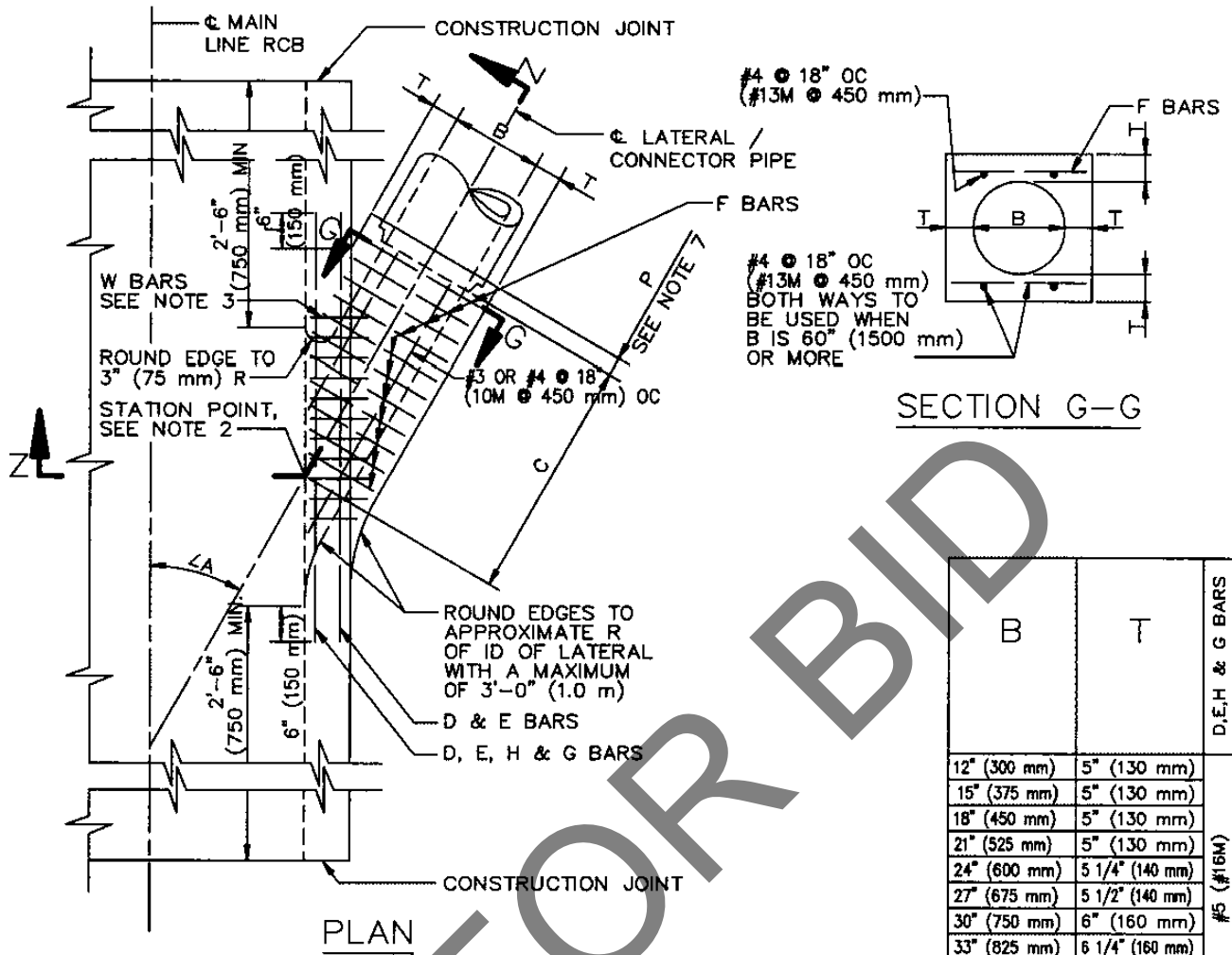

SECTION G-G

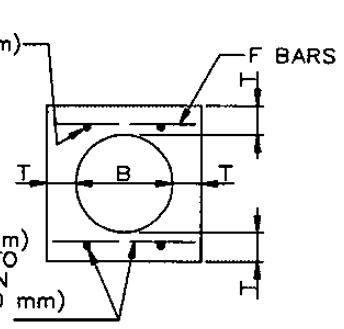

#4 @ 18" OC
 (#13M @ 450 mm)
 BOTH WAYS TO
 BE USED WHEN
 B IS 60" (1500 mm)
 OR MORE

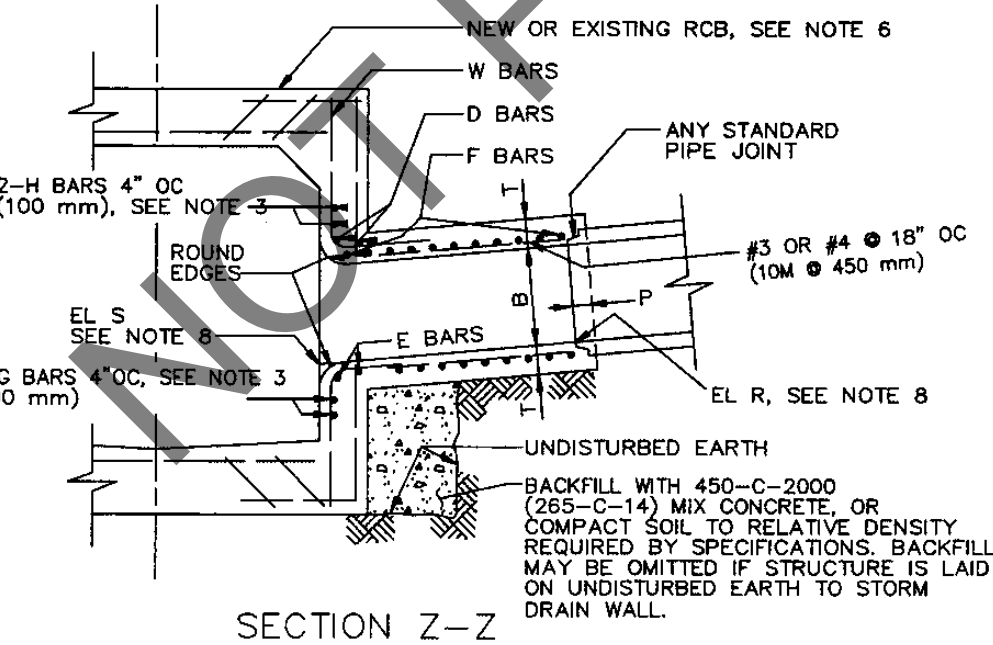

SECTION Z-Z

B	T	D, E, H & G BARS	F BARS
12" (300 mm)	5" (130 mm)	#5 (#16M)	#4 @ 6" (#13M @ 150 mm) OC
15" (375 mm)	5" (130 mm)		
18" (450 mm)	5" (130 mm)		
21" (525 mm)	5" (130 mm)		
24" (600 mm)	5 1/4" (140 mm)		
27" (675 mm)	5 1/2" (140 mm)		
30" (750 mm)	6" (160 mm)		
33" (825 mm)	6 1/4" (160 mm)		
36" (900 mm)	6 1/2" (170 mm)		
39" (990 mm)	7" (180 mm)		
42" (1050 mm)	7 1/2" (190 mm)	#6 (#19M)	#5 @ 6" (#16M @ 150 mm) OC
45" (1125 mm)	7 3/4" (200 mm)		
48" (1220 mm)	8" (210 mm)		
51" (1275 mm)	8 1/2" (220 mm)		
54" (1350 mm)	9" (230 mm)		
57" (1500 mm)	9 1/4" (240 mm)		
60" (1500 mm)	9 1/2" (240 mm)		
63" (1650 mm)	10" (260 mm)		
66" (1680 mm)	10 1/4" (260 mm)		
69" (1800 mm)	10 3/4" (280 mm)		
72" (1850 mm)	11 (280 mm)	#7 (#22M)	#5 @ 6" (#16M @ 150 mm) OC
78" (1950 mm)	11 3/4" (300 mm)		
84" (2100 mm)	12 1/2" (320 mm)		
90" (2400 mm)	13 1/4" (340 mm)		
96" (2440 mm)	14" (360 mm)		
102" (2550 mm)	15 1/2" (400 mm)		
108" (2700 mm)	16" (410 mm)		
114" (3000 mm)	16 1/2" (420 mm)		
120" (3050 mm)	17" (430 mm)		
126" (3150 mm)	17" (430 mm)		
132" (3300 mm)	17 1/2" (450 mm)		
138" (3450 mm)	17 1/2" (450 mm)		
144" (3600 mm)	18" (460 mm)		

STANDARD PLANS FOR PUBLIC WORKS CONSTRUCTION

PROMULGATED BY THE
 PUBLIC WORKS STANDARDS INC.
 GREENBOOK COMMITTEE
 1984
 REV. 1996, 2009

JUNCTION STRUCTURE - PIPE TO RCB

STANDARD PLAN
333-2

USE WITH STANDARD SPECIFICATIONS FOR PUBLIC WORKS CONSTRUCTION

SHEET 1 OF 2

NOTES

1. VALUES FOR A, B AND C SHALL BE SHOWN ON THE PLANS. ELEVATION R AND ELEVATION S SHALL BE SHOWN WHEN REQUIRED PER NOTE 8.
2. STATIONS SPECIFIED ON THE PLANS APPLY AT THE INTERSECTION OF CENTERLINES OF MAIN LINE AND LATERALS, EXCEPT THAT STATIONS FOR CATCH BASIN CONNECTOR PIPES APPLY AT INSIDE WALL OF STRUCTURE.
3. REINFORCING STEEL SHALL CONFORM TO ASTM A 615, GRADE 40, (ASTM A 615M, GRADE 300), AND SHALL TERMINATE 1 1/2" (40 mm) CLEAR OF CONCRETE SURFACE UNLESS OTHERWISE SHOWN.
 - a. W BARS ARE OF SIZE AND SPACING SPECIFIED FOR WALL STEEL ON PLANS, AND SHALL BE CUT IN CENTER OF OPENING AND BENT INTO TOP AND BOTTOM OF JUNCTION STRUCTURE.
 - b. OMIT H BARS WHEN SOFFIT OF SPUR IS 12" (300 mm) OR LESS BELOW SOFFIT OF MAIN LINE, AND OMIT G BARS WHEN INVERT OF SPUR IS 12" (300 mm) OR LESS ABOVE FLOOR OF MAIN LINE.
4. JUNCTION STRUCTURE SHALL BE POURED MONOLITHICALLY WITH MAIN LINE, MANHOLE OR TRANSITION STRUCTURE.
5. FLOOR OF STRUCTURE SHALL BE STEEL-TROWELED TO THE SPRING LINE.
6. WHEN CONNECTING TO EXISTING RCB, BREAKOUT LIMITS AND DETAILS SHALL BE SHOWN ON THE PLANS.
7. EMBEDMENT, P, SHALL BE 5" (130 mm) FOR B = 96" (2400 mm) OR LESS 8" (200 mm) FOR B OVER 96" (2400 mm).
8. IF ELEVATION R AND ELEVATION S ARE NOT SHOWN ON THE PLANS THEN THE INLET OPENING SHALL FALL 6" (150 mm) BELOW THE SOFFIT OF THE MAIN LINE WITH THE INLET PIPE LAID ON A STRAIGHT GRADE FROM MAIN LINE TO CATCH BASIN OR TO GRADE BREAK IN INLET LINE. ELEVATION S SHALL BE SHOWN ON THE PLANS IF THE INLET OPENING FALLS MORE THAN 6" (150 mm) BELOW THE SOFFIT OF THE MAIN LINE WITH THE INLET PIPE LAID ON A STRAIGHT GRADE AS STATED ABOVE.
ELEVATION R SHALL BE SHOWN ON THE PLANS ONLY WHEN A STUB IS TO BE PROVIDED FOR A FUTURE CONNECTION.
9. LATERALS OR CONNECTOR PIPES 24" (600 mm) OR LESS IN DIAMETER SHALL BE NO MORE THAN 5' (1.5 m) ABOVE THE INVERT. LATERALS OR CONNECTOR PIPES 27" (675 mm) OR LARGER IN DIAMETER SHALL BE NO MORE THAN 18" (450 mm) ABOVE THE INVERT, WITH THE EXCEPTION THAT CATCH BASIN CONNECTOR PIPES LESS THAN 50' (15 m) IN LENGTH SHALL NOT BE MORE THAN 5' (1.5 m) ABOVE THE INVERT.
10. THE NEED FOR AN EDGE BEAM AND/OR ADDITIONAL REINFORCEMENT SHALL BE INVESTIGATED BY THE ENGINEER FOR ANY ONE OF THE FOLLOWING CONDITIONS:
 - a. ANGLE A IS LESS THAN 30°
 - b. TOP OF INLET PIPE IS LESS THAN 6" (150 mm) BELOW THE SOFFIT
 - c. FLOW LINE OF INLET PIPE IS LESS THAN 7" (180 mm) ABOVE THE THE FLOOR OF THE RCB AT THE INSIDE FACE

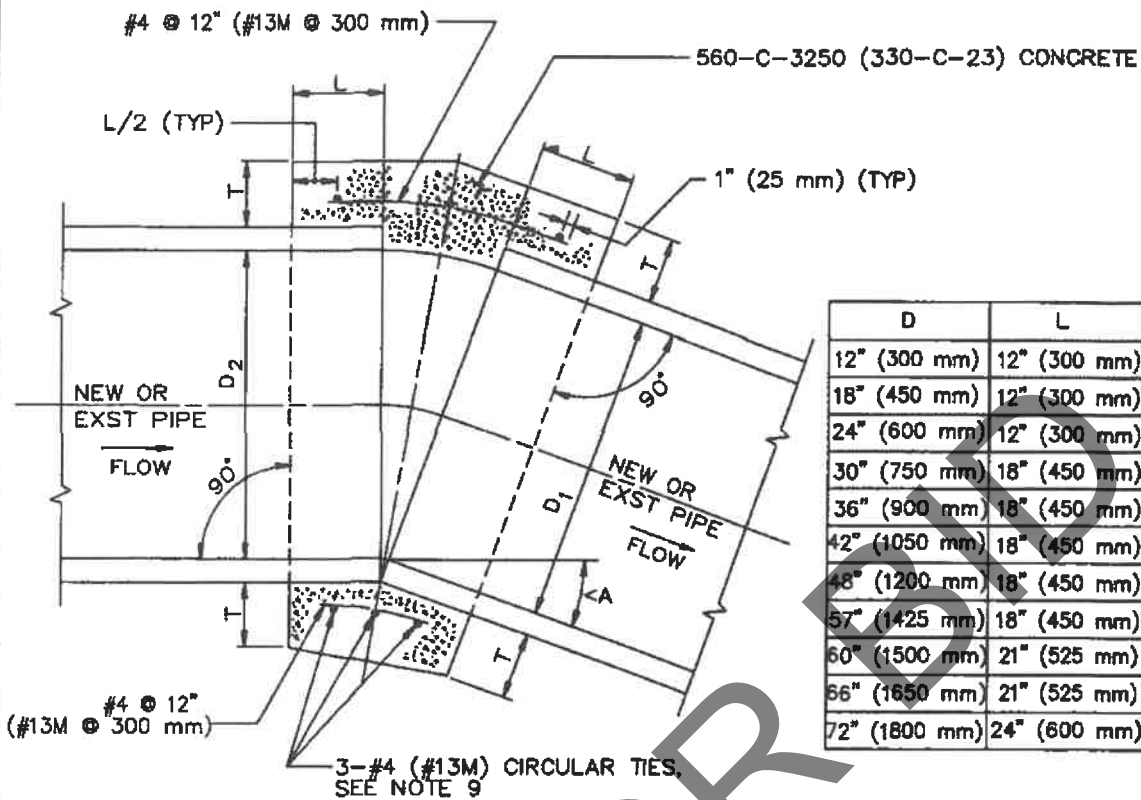

D	L	T
12" (300 mm)	12" (300 mm)	4" (100 mm)
18" (450 mm)	12" (300 mm)	5" (125 mm)
24" (600 mm)	12" (300 mm)	6" (150 mm)
30" (750 mm)	18" (450 mm)	7" (175 mm)
36" (900 mm)	18" (450 mm)	9" (225 mm)
42" (1050 mm)	18" (450 mm)	9" (225 mm)
48" (1200 mm)	18" (450 mm)	10" (250 mm)
57" (1425 mm)	18" (450 mm)	10" (250 mm)
60" (1500 mm)	21" (525 mm)	11" (275 mm)
66" (1650 mm)	21" (525 mm)	11" (275 mm)
72" (1800 mm)	24" (600 mm)	12" (300 mm)

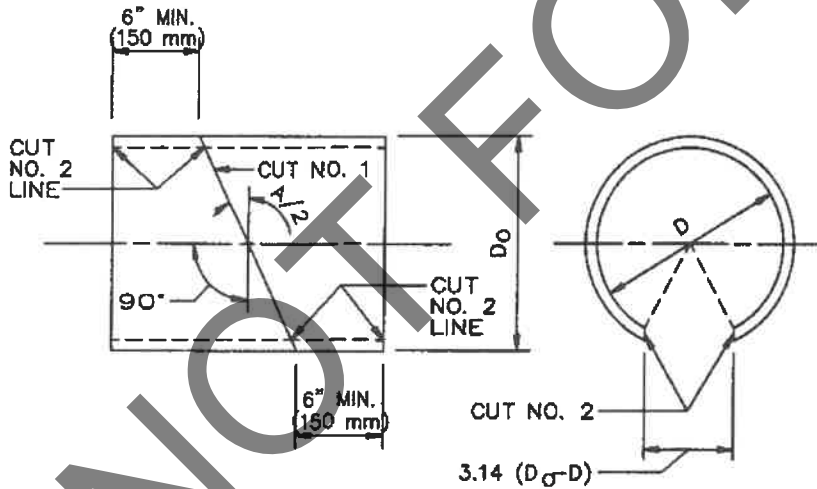

DETAIL "A" (SEE NOTE 10)

SONO-TUBE, OR EQUAL, INTERIOR FORM

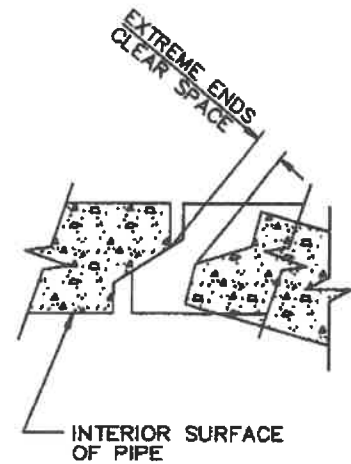

DETAIL "B"

TYPICAL JOINT FOR

REINFORCED CONCRETE PIPE

CUT NO. 1: SAW THE TUBE AT AN ANGLE OF A/2 WITH THE TRANSVERSE PLANE. REVERSE ONE SECTION AND TAPE BOTH SECTIONS TOGETHER FORMING THE DEFLECTION ANGLE A.

CUT NO. 2: SAW THE TUBE LONGITUDINALLY REMOVING A STRIP 3.14 (D_o-D) WIDE ON THE SIDE OPPOSITE THE OPEN JOINT. BEND THE ENDS OF THE CUT TOGETHER AND INSERT THE TUBE IN THE PIPE.

STANDARD PLANS FOR PUBLIC WORKS CONSTRUCTION

PROMULGATED BY THE
PUBLIC WORKS STANDARDS INC.
GREENBOOK COMMITTEE
1992

REV. 1996, 1997, 1999, 2009

CONCRETE COLLAR FOR RCP
12" (300 mm) THROUGH 72" (1800 mm)

USE WITH STANDARD SPECIFICATIONS FOR PUBLIC WORKS CONSTRUCTION

STANDARD PLAN

380-4

SHEET 1 OF 2

NOTES

1. A CONCRETE COLLAR IS REQUIRED WHERE THE CHANGE IN GRADE EXCEEDS 10%.
2. FOR CURVE JOINTS (SEE DETAIL B, SHEET 1)
 - IF THE EXTREME ENDS OF THE PIPE LEAVE A CLEAR SPACE THAT IS GREATER THAN 1" (25 mm), BUT IS LESS THAN 3" (75 mm) A CONCRETE COVER IS REQUIRED IN ACCORDANCE WITH SSPWC 306-1.2.4.
 - IF THE EXTREME ENDS OF THE PIPE LEAVE A CLEAR SPACE THAT IS EQUAL TO OR GREATER THAN 3" (75 mm), BUT LESS THAN 6" (150 mm), A CONCRETE COLLAR IS REQUIRED. IF THE CLEAR SPACE IS 6" (150 mm) OR GREATER, A TRANSITION STRUCTURE IS REQUIRED.
3. CONCRETE COLLAR SHALL NOT BE USED FOR A SIZE CHANGE ON THE MAIN LINE.
4. CONNECTOR PIPES
 - A. WHERE PIPES OF DIFFERENT DIAMETERS ARE JOINED WITH A CONCRETE COLLAR, L AND T SHALL BE THOSE OF THE LARGER PIPE. $D=D_1$ OR D_2 , WHICHEVER IS GREATER.
 - B. WHEN D_1 IS EQUAL TO OR LESS THAN D_2 , JOIN INVERTS AND WHEN D_1 IS GREATER THAN D_2 , JOIN SOFFITS.
5. FOR PIPE LARGER THAN 72" (1800 mm) SPECIAL COLLAR DETAILS ARE REQUIRED.
6. FOR PIPE SIZE NOT LISTED USE NEXT SIZE LARGER.
7. REINFORCEMENT SHALL CONFORM TO ASTM A 615 (A 615 M) GRADE 40 (300).
8. WHERE REINFORCING IS REQUIRED THE DIAMETER OF THE CIRCULAR TIES SHALL BE $D+(2X \text{ WALL THICKNESS}) + T$.
9. REINFORCING SHALL BE USED WHERE THE PIPE DIAMETER IS GREATER THAN 21" (525 mm) AND ON ALL PIPES WHERE THE SPACES BETWEEN THE EXTREME OUTER ENDS IS 3" (75 mm) OR LARGER.

CIRCULAR TIES:

PIPE DIAMETER	NO. OF CIRCULAR TIES
21" (525 mm) OR LESS	3
24" (600 mm) TO 30" (750 mm)	3
33" (825 mm) TO 57" (1425 mm)	4
60" (1500 mm) TO 72" (1800 mm)	5

WHERE THE SPACE BETWEEN PIPE ENDS EXCEEDS 3" (75 mm), THE NUMBER OF CIRCULAR TIES SHALL BE INCREASED TO MAINTAIN AN APPROXIMATE SPACING OF 6" (150 mm) O.C.

10. WHERE THE PIPE IS 21" (525 mm) OR LESS IN DIAMETER AN INTERIOR FORM OF UNSEALED SONO-TUBE OR EQUAL SHALL BE USED TO PROVIDE A SMOOTH INTERIOR JOINT. THE PAPER FORM MAY BE LEFT IN PLACE (SEE DETAIL A). WHEN THE PIPE IS 24" (600 mm) OR LARGER A REMOVABLE INTERIOR FORM SHALL BE USED OR THE INTERIOR JOINT SHALL BE COMPLETELY FILLED WITH MORTAR AND NEATLY POINTED.

STANDARD PLANS FOR PUBLIC WORKS CONSTRUCTION

STANDARD PLAN

CONCRETE COLLAR FOR RCP
12" (300 mm) THROUGH 72" (1800 mm)

380-4

SHEET 2 OF 2

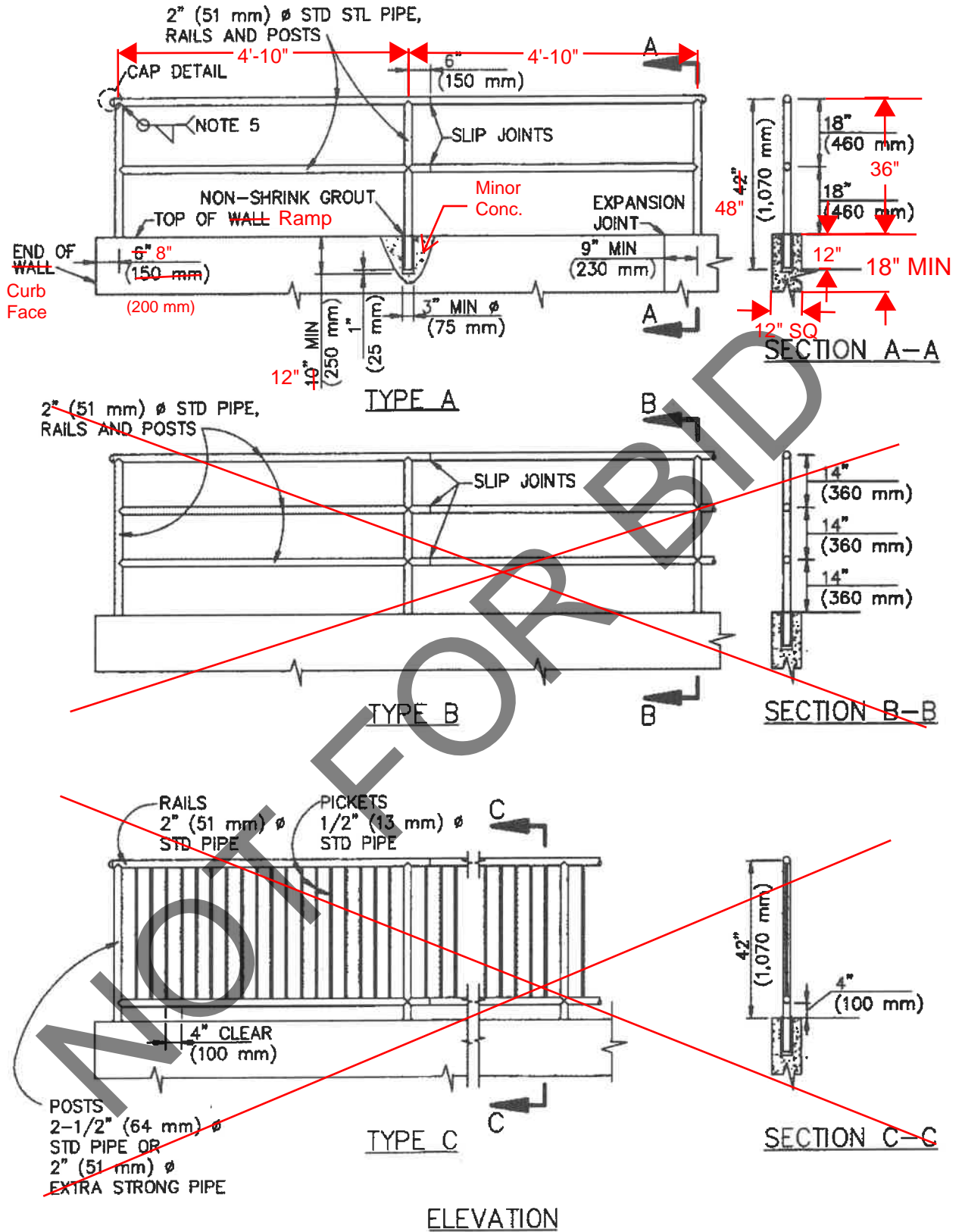

STANDARD PLANS FOR PUBLIC WORKS CONSTRUCTION

PROMULGATED BY THE
PUBLIC WORKS STANDARDS INC.
GREENBOOK COMMITTEE
1993
REV. 1996, 2005, 2009

METAL HAND RAILINGS

USE WITH STANDARD SPECIFICATIONS FOR PUBLIC WORKS CONSTRUCTION

STANDARD PLAN

606-3

SHEET 1 OF 3

(Modified)

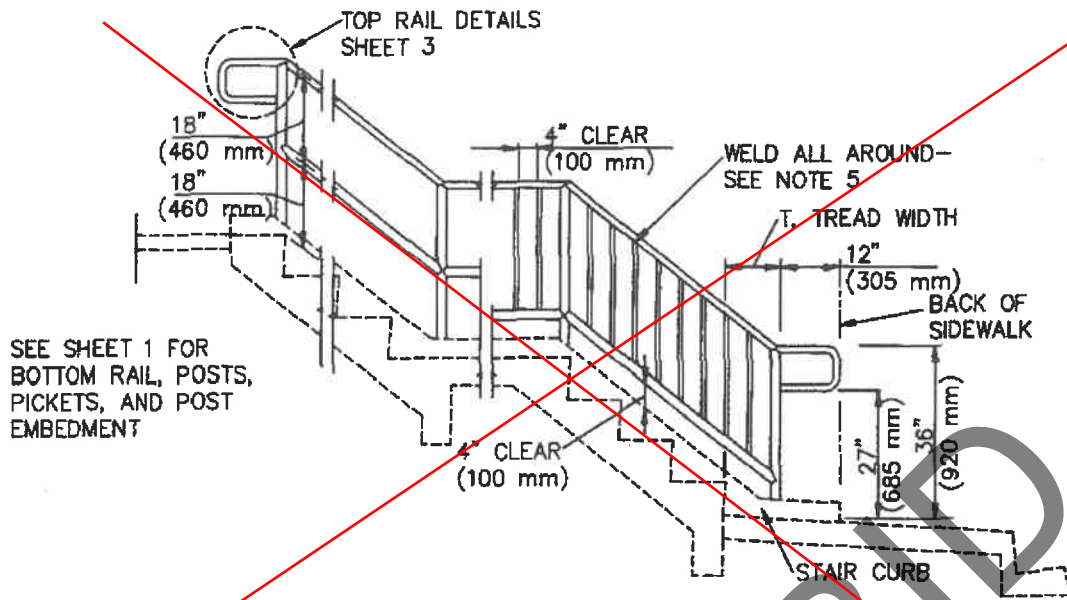

TYPE A TYPE C
HANDRAIL INSTALLATION ON STAIRWAYS

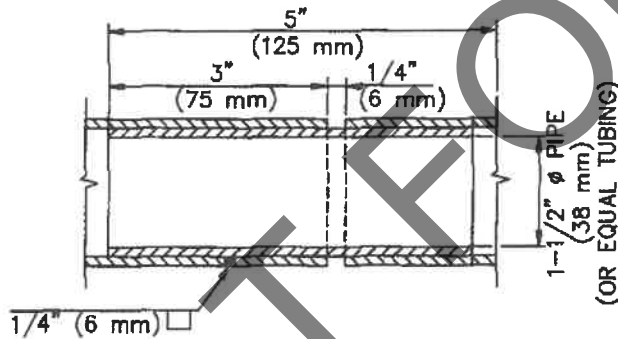

SLIP JOINT DETAIL

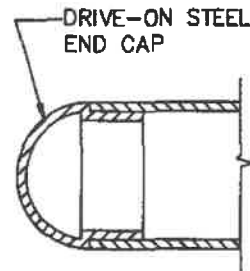

CAP DETAIL FOR RAIL END

NOTES:

- ~~1. USE TYPE C WHERE ADJACENT GRADE IS MORE THAN 2'-6" (760 mm) BELOW LANDING OR SIDEWALK FINISHED SURFACE.~~
2. RAILS, POSTS, AND PICKETS SHALL BE GALVANIZED STEEL PIPE.
- ~~3. PROVIDE SLIP JOINTS AT STAIRWAY EXPANSION JOINTS, 24' (7.3 m) MAXIMUM.~~
- ~~4. MAXIMUM SPACING OF POSTS SHALL BE 8'-0" (2.44 m) ON STRAIGHT ALIGNMENTS, AND 6'-0" (1.83 m) ON CURVED ALIGNMENTS WITH LESS THAN 30' (9.1 m) RADIUS. MAKE SPACING UNIFORM BETWEEN CHANGES IN ALIGNMENT.~~
5. WELDS SHALL BE SLOT OR FILLET WELDS EQUAL TO THICKNESS OF PIPE. WELD ALL JOINTS ALL AROUND.

STANDARD PLANS FOR PUBLIC WORKS CONSTRUCTION

METAL HAND RAILINGS

STANDARD PLAN

606-3

SHEET 2 OF 3

(Modified)

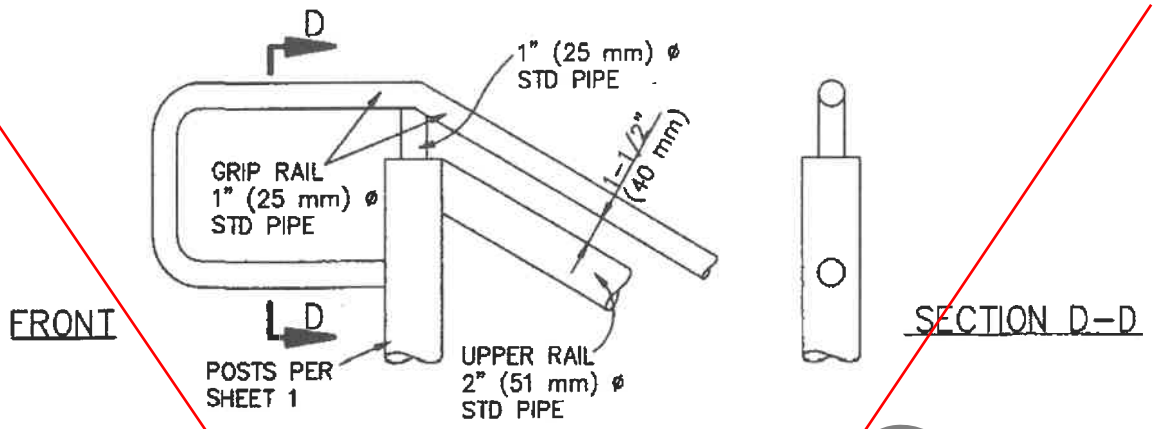

TOP RAIL TYPE 1

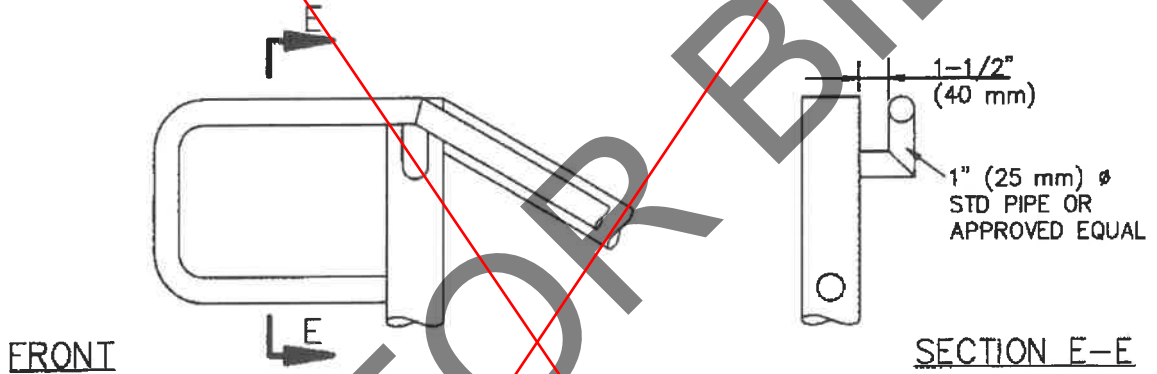

TOP RAIL TYPE 2

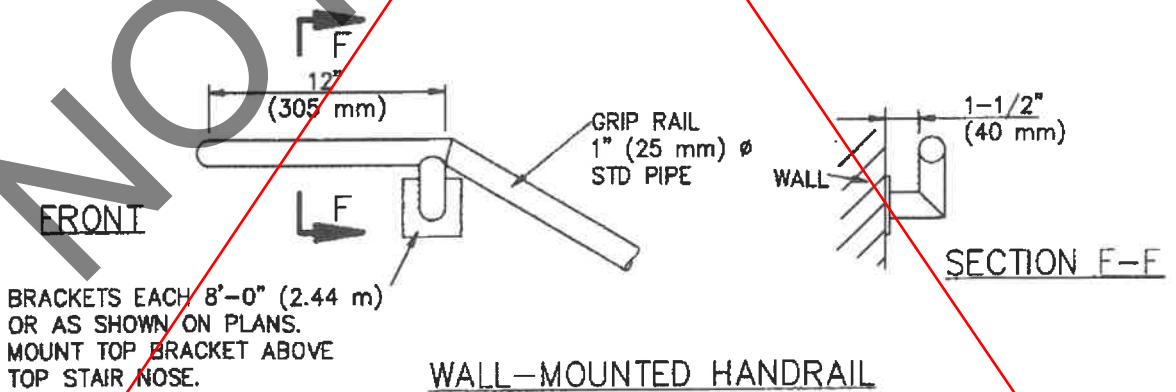

STANDARD PLANS FOR PUBLIC WORKS CONSTRUCTION

STANDARD PLAN

METAL HAND RAILINGS

606-3

SHEET 3 OF 3

(Modified)

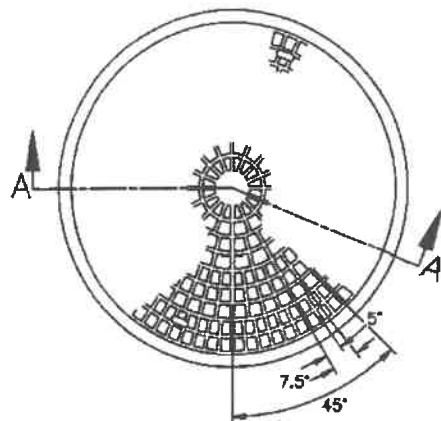

TOP OF COVER

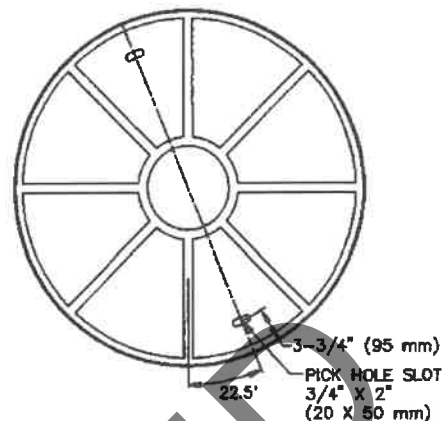

BOTTOM OF COVER

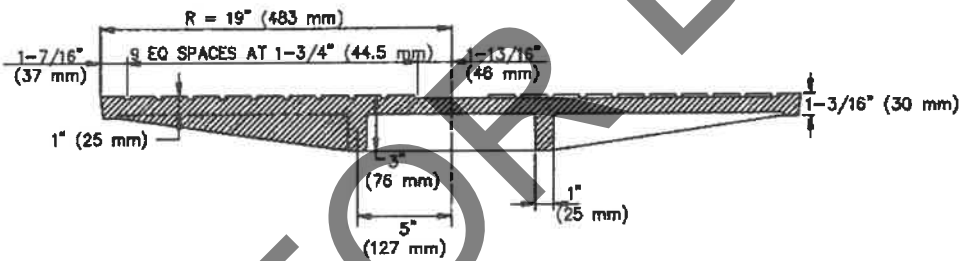

SECTION A-A

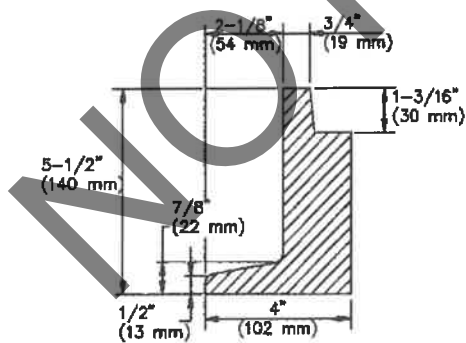

FRAME DETAIL

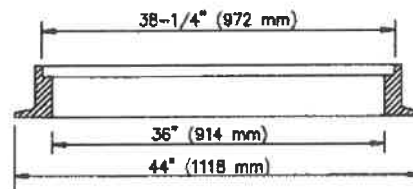

SECTION THRU FRAME

STANDARD PLANS FOR PUBLIC WORKS CONSTRUCTION

PROMULGATED BY THE
PUBLIC WORKS STANDARDS INC.
GREENBOOK COMMITTEE
1984
REV. 1992, 1996, 2009

**36" (914 mm) MANHOLE FRAME
AND COVER**

USE WITH STANDARD SPECIFICATIONS FOR PUBLIC WORKS CONSTRUCTION

STANDARD PLAN

633-3

SHEET 1 OF 2

NOTES:

1. THE CAST IRON USED SHALL CONFORM TO ASTM A-48 CLASS 35B.
2. COVERS SHALL BE CAST WITH THE LETTER "D" FOR STORM DRAINS AND "S" FOR SEWERS, AND THE AGENCY'S IDENTIFICATION IN ACCORDANCE WITH INSTRUCTIONS FURNISHED BY THE AGENCY. THE LETTER "D" OR "S" SHALL BE APPROXIMATELY 2-1/2" (65 mm) HIGH WITH 1/2" (15 mm) LINE WIDTH, AND PLACED IN THE CENTER OF THE COVER. ALL LETTERS SHALL BE FLUSH WITH THE FINISHED SURFACE OF THE COVER.
3. FOUNDRY IDENTIFYING MARK, HEAT AND DATE SHALL BE CAST ON THE BOTTOM OF THE COVER AND ON THE INSIDE OF THE FRAME.
4. IMPORTED COVERS AND FRAMES SHALL HAVE THE COUNTRY OF ORIGIN MARKING IN COMPLIANCE WITH FEDERAL REGULATIONS.
5. WEIGHT OF FRAME SHALL BE 335 LBS (152 kg). WEIGHT OF COVER SHALL BE 340 LBS (154 kg). ACTUAL WEIGHTS SHALL BE WITHIN A RANGE OF 95% TO 110%.
6. THE MANHOLE FRAME AND COVER SHALL BE INSPECTED BY THE ENGINEER PRIOR TO SHIPMENT TO THE JOBSITE. ACCEPTANCE WILL BE INDICATED BY THE AGENCY'S MARK.
7. THE PROOF-LOAD FOR TEST METHOD B OF SSPWC 206-3.2 IS 41,300 LBS (183 kN).
8. COVERS FOR MANHOLES LOCATED IN EASEMENTS, ALLEYS, PARKWAYS AND ALL PLACES OTHER THAN PAVED STREETS SHALL BE PROVIDED WITH SOCKET-SET SCREW LOCKING DEVICES. DRILL AND TAP TWO HOLES TO A DEPTH OF 1" (25 mm) AT 90 DEGREES TO PICK HOLE AND INSTALL 3/4" x 3/4" (20 x 20 mm) STAINLESS STEEL SOCKET-SET SCREWS WITH 3/8" (10 mm) RECESSED HEX HEAD. ALL THREADS SHALL BE N.C.

STANDARD PLANS FOR PUBLIC WORKS CONSTRUCTION

**36" (914 mm) MANHOLE FRAME
AND COVER**

STANDARD PLAN

633-3

SHEET 2 OF 2

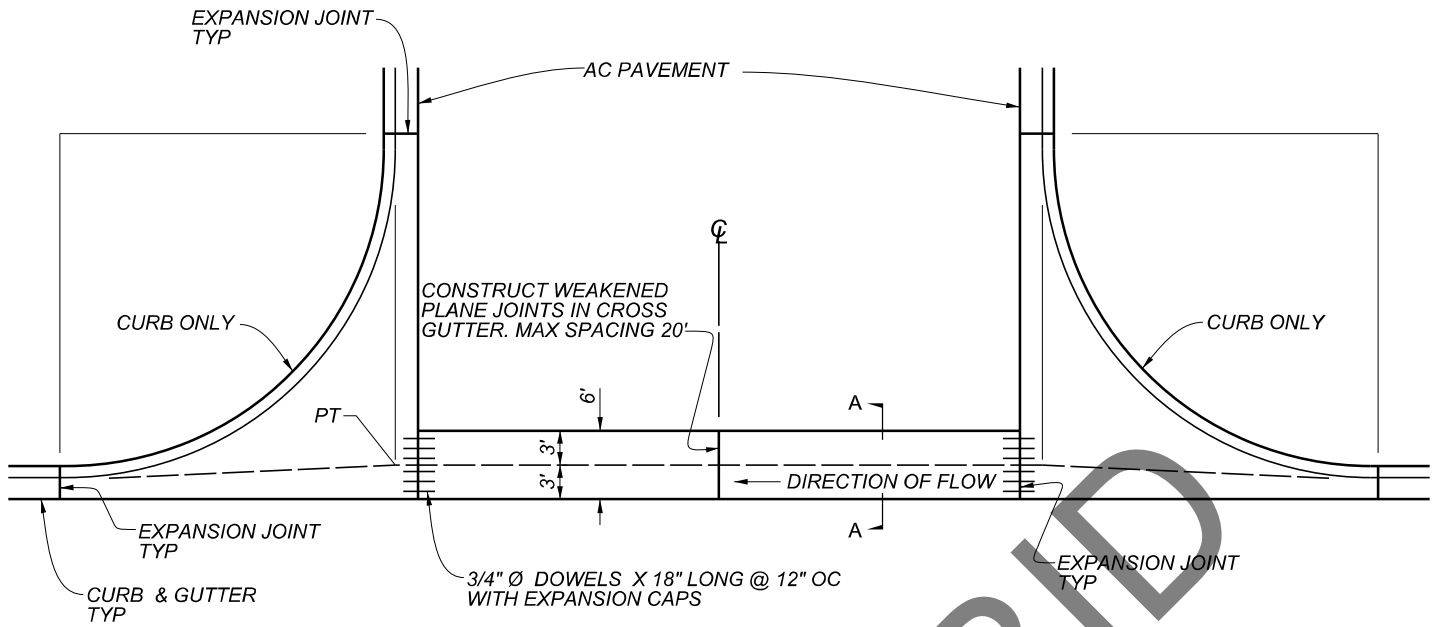

PLAN

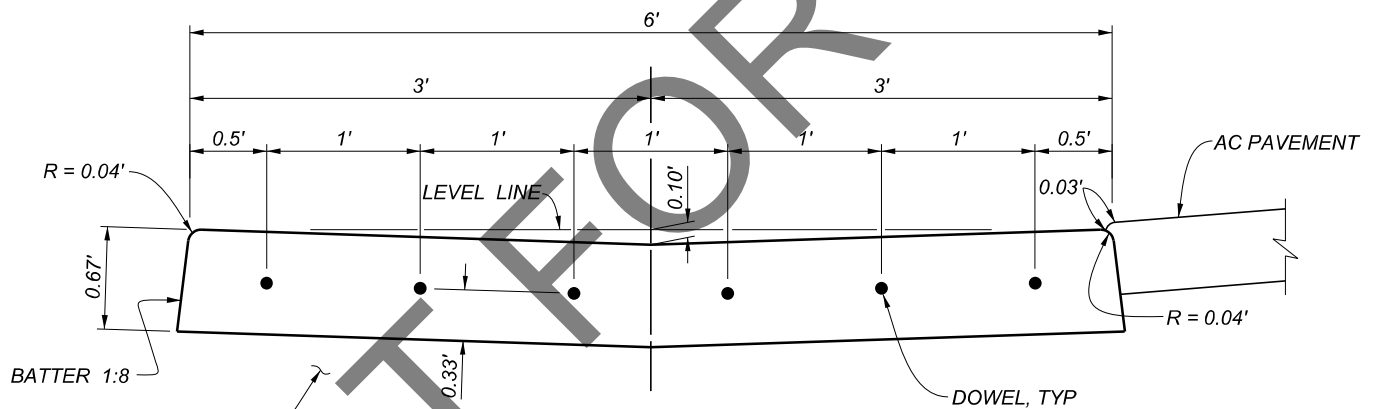

SECTION A-A

0.67' COMPACTED CLASS 2
BASE UNDER CONCRETE

NOTES:

1. CLASS 520-C-3250 PCC SHALL BE USED FOR COMPLETE CROSS GUTTER AS SHOWN.
2. IMMEDIATELY AFTER COMPLETION OF FINISHING, CONCRETE CURING COMPOUND SHALL BE APPLIED AS A FINE SPRAY TO ALL EXPOSED SURFACES INCLUDING THE BACK OF CURB.

APPROVED BY:

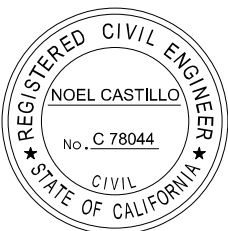

Noel Castillo
 NOEL A. CASTILLO
 CITY ENGINEER
 09-20-19
 DATE

CITY OF MONTCLAIR

CROSS GUTTER

NO SCALE

STD. PLAN NO. 103

SHEET
1 of 1

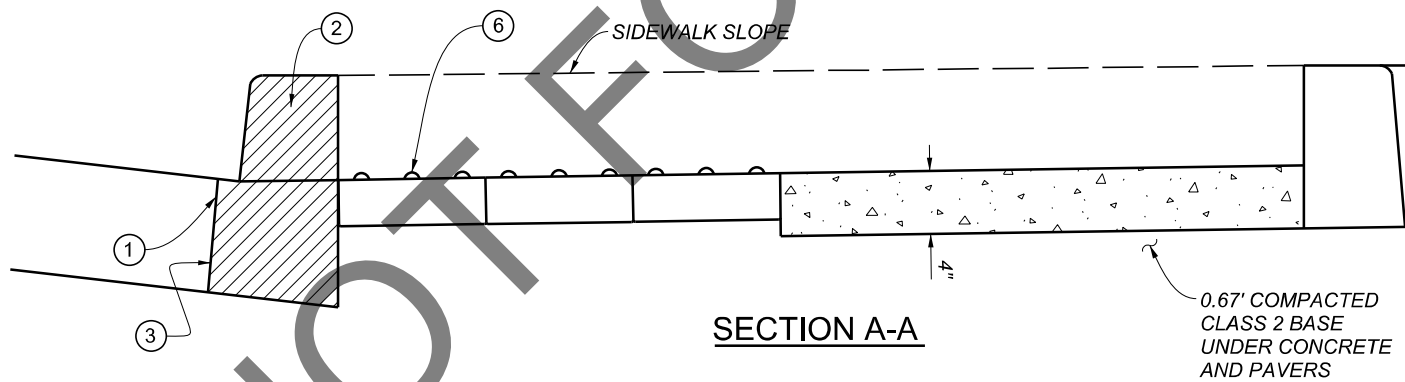
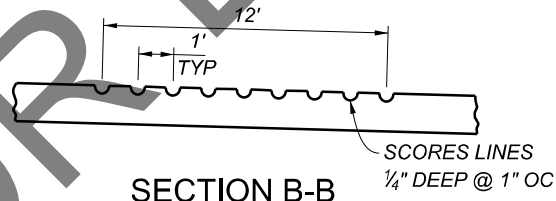
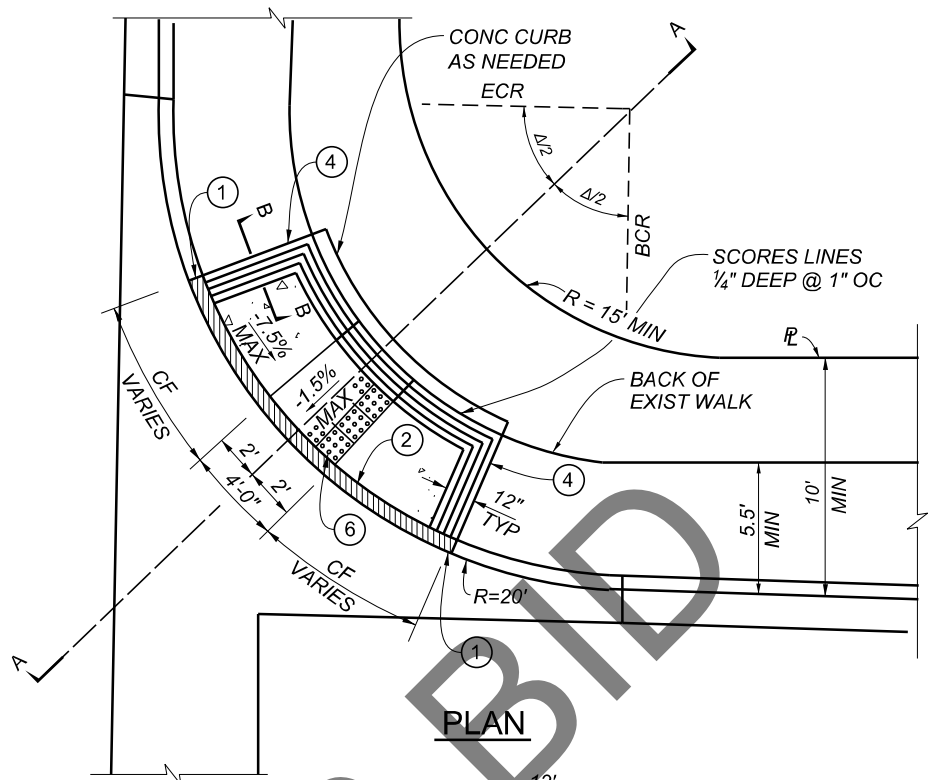

NOTES:

- 1. FOR CURB FACE OF 6" OR GREATER, X = 6'.
- 2. 4" TO 6", X VARIES 4' TO 6' LESS THAN 4", X = 4'.
- 3. RAMP SHALL HAVE A HEAVY BROOM FINISH.

CONSTRUCTION NOTES:

- ① SAW CUT A MINIMUM OF 6" DEPTH BEFORE BREAKING OFF CURB PORTION.
- ② REMOVE EXISTING CURB SHOWN CROSS-HATCHED AND EXISTING SIDEWALK
- ③ THOROUGHLY CLEAN WITH WIRE BRUSH AND APPLY HUNT 101 EPOXY RESIN BOND OR APPROVED EQUAL TO MANUFACTURER'S RECOMENDATION AND TO SATISFACTION OF THE CITY ENGINEER.
- ④ LIMIT OF SIDEWALK REMOVAL.
- ⑤ CLASS 520-C-3250 PCC SHALL BE USED UNLESS OTHERWISE SPECIFIED.
- ⑥ THE DETECTABLE WARNING SURFACE SHALL BE WAUSAU ADA-1 12" SQUARE PAVERS, COLOR A-80.

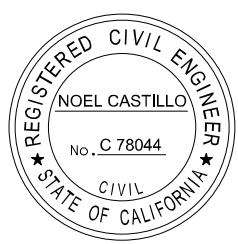

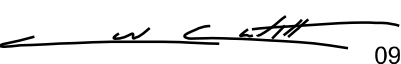
APPROVED BY:

 NOEL A. CASTILLO
 CITY ENGINEER
 09-20-19
 DATE

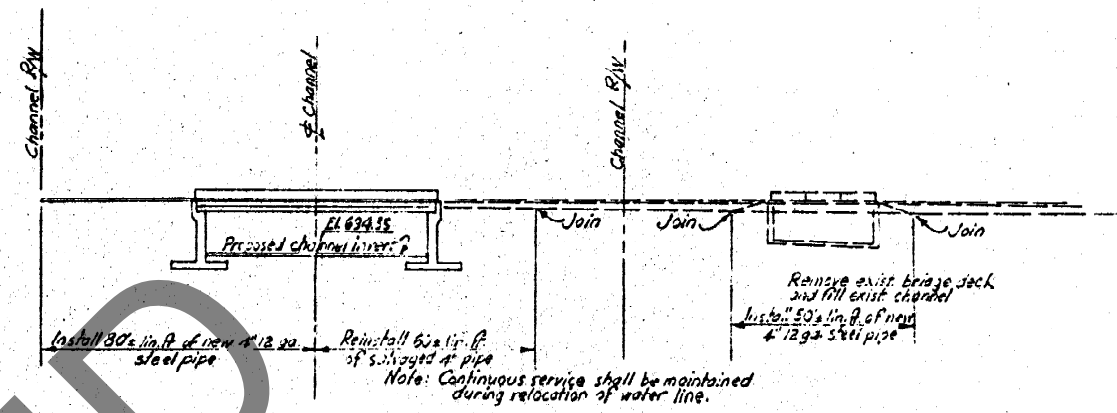
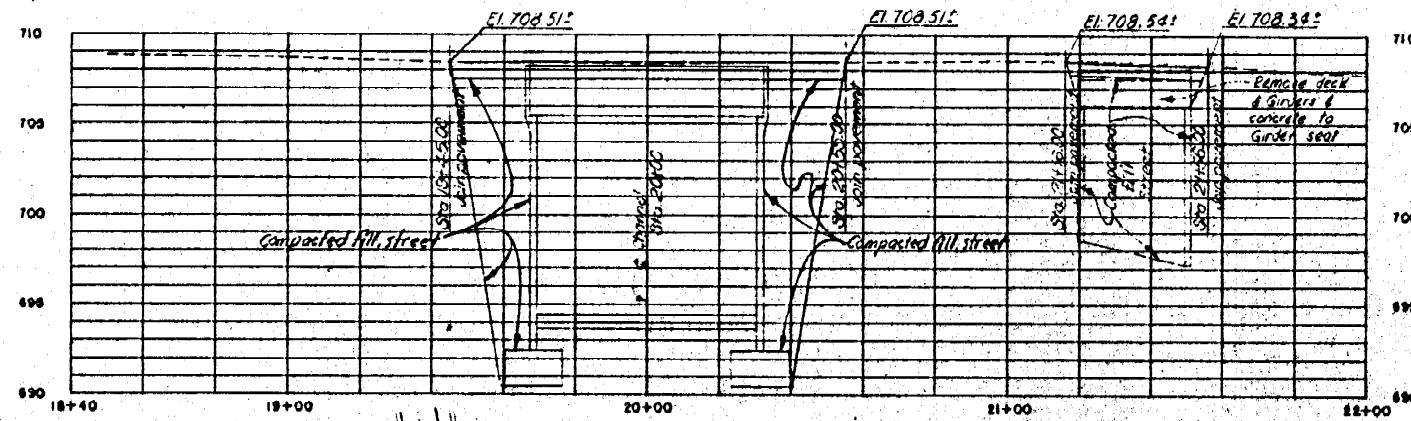
CITY OF MONTCLAIR		
WHEELCHAIR RAMP AT EXISTING CURB RETURN		
NO SCALE	STD. PLAN NO. 117	SHEET 1 of 1

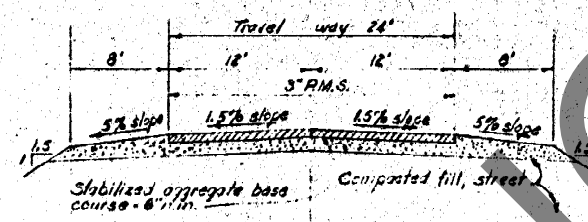
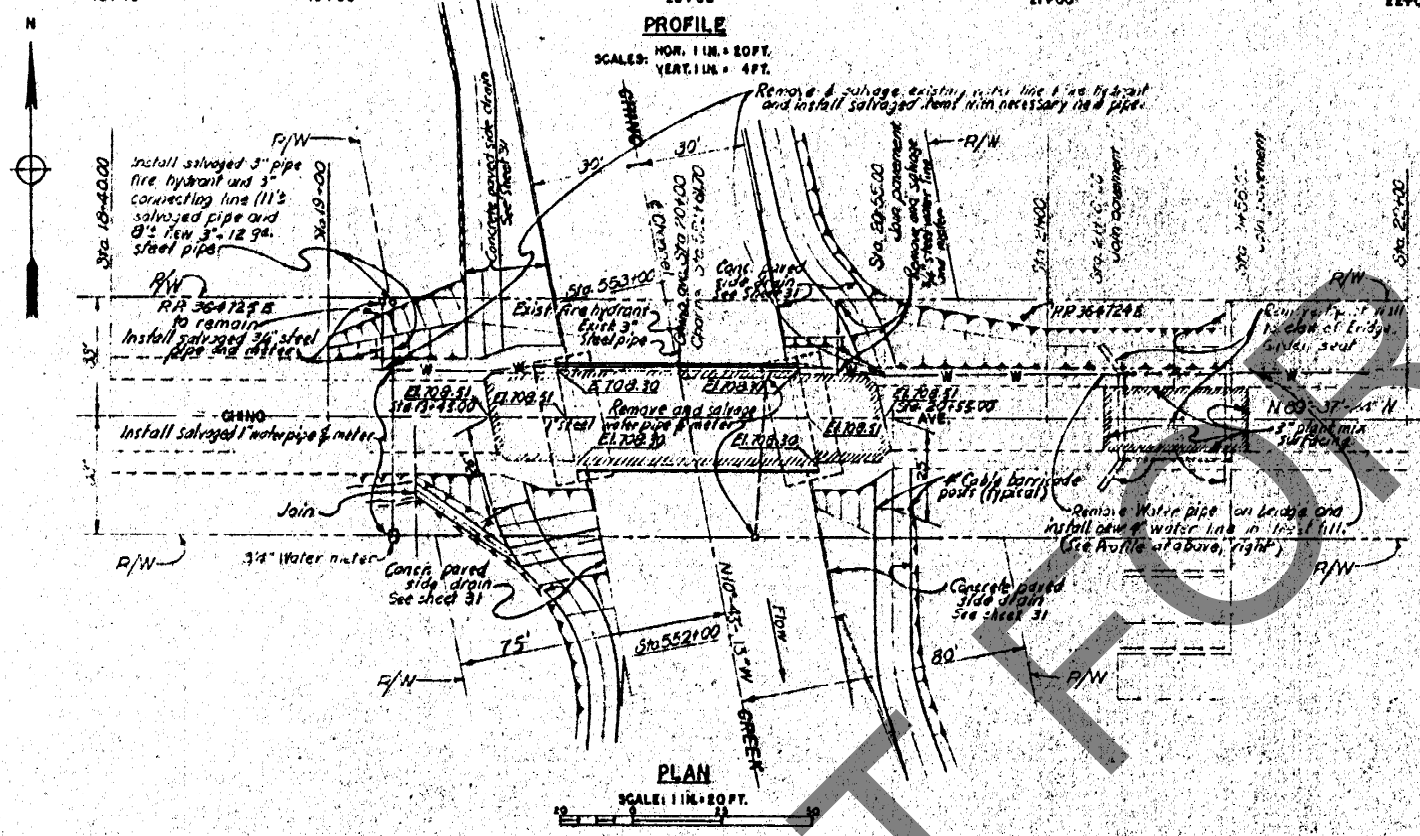

PROFILE
SCALE: 1 IN. = 20 FT.
RELOCATION OF 4" STEEL-WATER-LINE



TYPICAL PAVEMENT SECTION
AT EACH END OF BRIDGE
NOT TO SCALE

REFERENCE

For Index to Contract Drawings see sheet 1

RECORD DRAWING - AS CONSTRUCTED
DATE: _____ BY: _____

CORPS OF ENGINEERS, U. S. ARMY OFFICE OF THE DISTRICT ENGINEER LOS ANGELES, CALIFORNIA	
ENGINEER: H.A.H.	SANTA ANA RIVER BASIN, CALIFORNIA
DRAWN BY: J.L.M.	SAN ANTONIO AND CHINO CREEKS IMPROVEMENT
CHECKED BY: J.P.	CHINO CREEK CHANNEL
APPROVED BY: [Signature]	CHINO AVENUE TO RAMONA AVENUE
APPROVAL AUTHORITY: [Signature]	CHINO AVE. APPROACHES
SCALE AS SHOWN	DATE: NOVEMBER 1958
TO ACCOMPANY SPECIFICATIONS GIVEN 04-385-29-2	SHEET 38 OF 66
	FILE NO. (A & B) 109758

#1-101-12

GENERAL NOTES

Specifications
 Piers and Abutments
 Design: AASHTO dated 1933
 Live Loading: H 20-S16-44
 Unit Stresses
 Reinforced Concrete: f' = 2000 PSI
 s = 1030 PSI
 n = 10

Prestressed Deck Units
 Design: Criteria for prestressed concrete bridges, APR, 1954
 Unit Stresses
 Prestressed Concrete: f' = 250,000 PSI
 s1 = 175,000 PSI
 s2 = 5000 PSI
 s3 = 4000 PSI
 For additional general notes - See Sheet

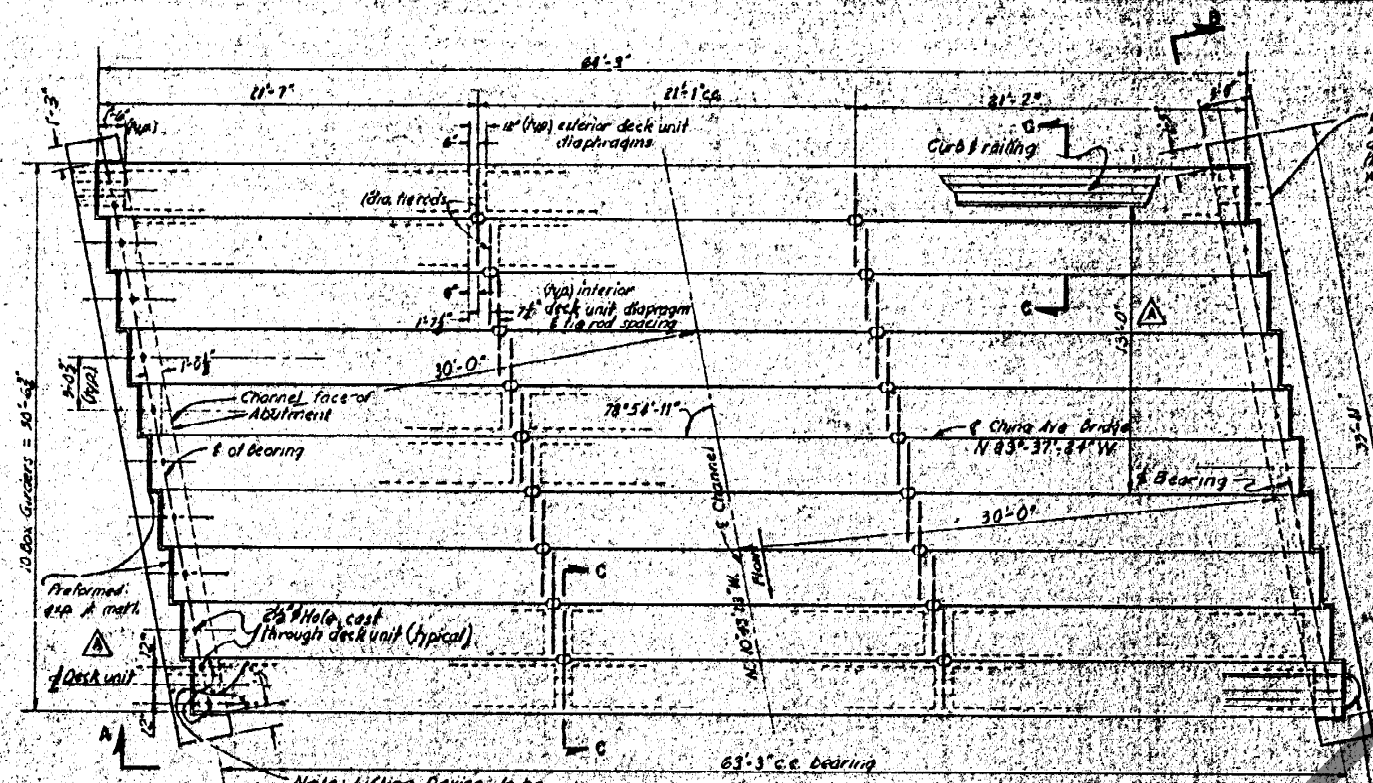

PLAN
 SCALE: 1/4" = 1 FT.

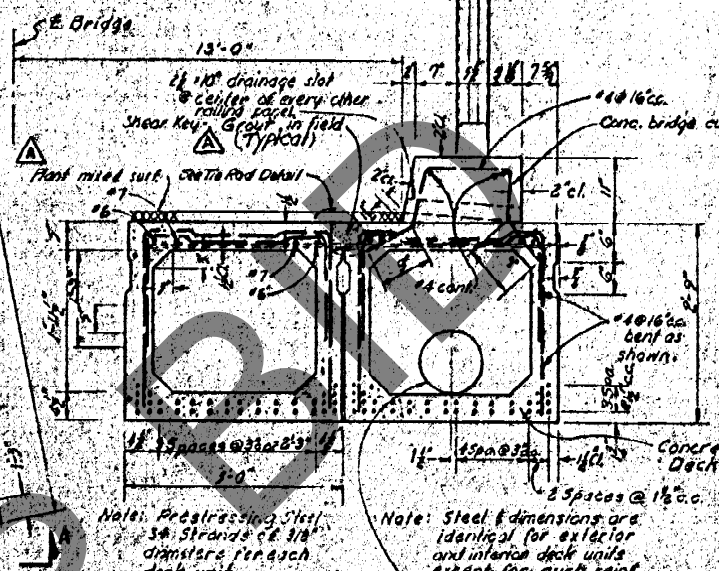

SECTION C-C
 SCALE: 1/4" = 1 FT.

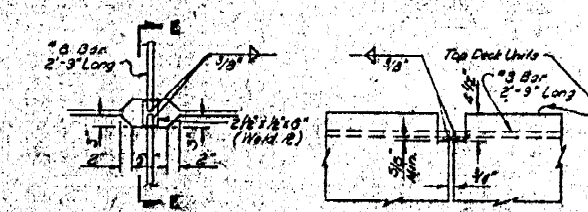

PLAN
 SCALE: 1/4" = 1 FT.

SECTION E-E
 SCALE: 1/4" = 1 FT.

TIE ROD DETAILS

Note: Lifting device to be installed by manufacturer (typical for all deck unit bridges.)

Note: Parapet walls shall be poured after deck units are in place.

Note: Prestressing Steel: 34 Strands of 3/8" diameter per each deck unit.

Note: Steel dimensions are identical for exterior and interior deck units except for curb reinforcement.

Provide 10" dia. holes thru diaphragms and mid sections of each exterior deck unit.

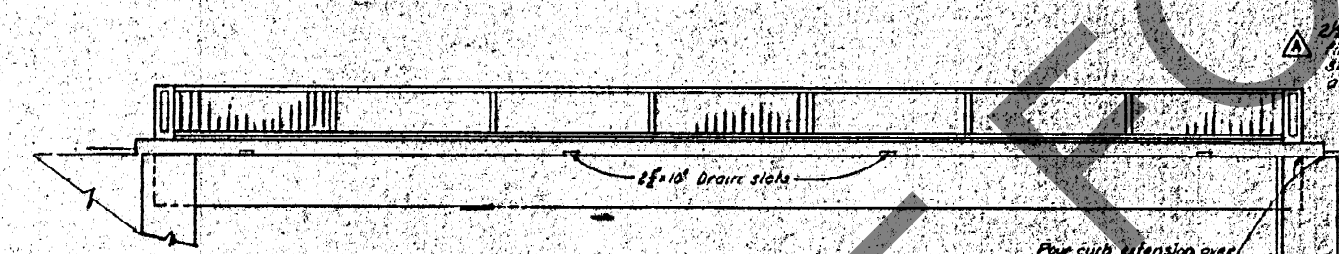

ELEVATION A-A
 SCALE: 1/4" = 1 FT.

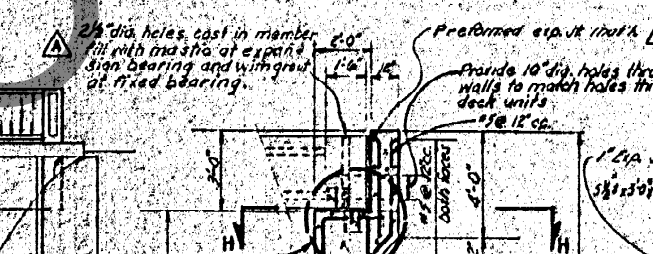

DETAIL G-G
 SCALE: 1/4" = 1 FT.

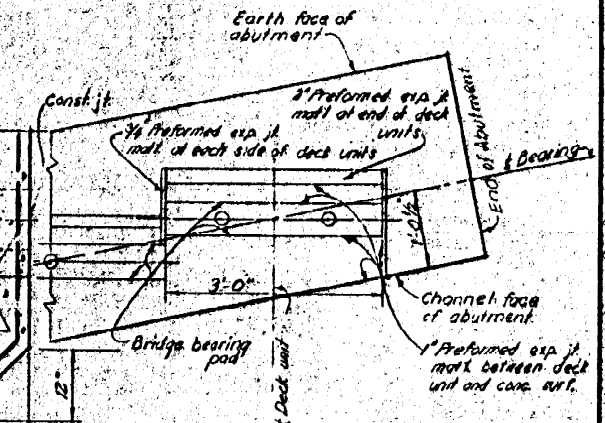

SECTION H-H
 SCALE: 1/4" = 1 FT.

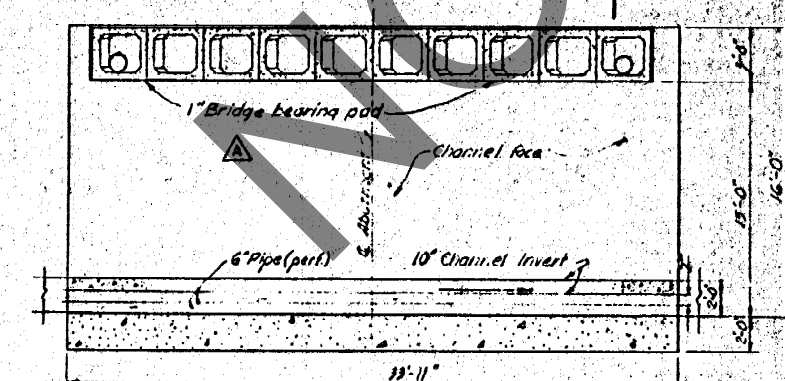

SECTION B-B
 SCALE: 1/4" = 1 FT.

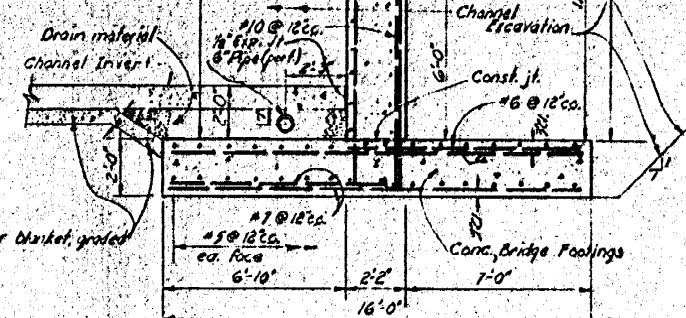

SECTION D-D
 SCALE: 3/8" = 1 FT.

REFERENCE

For Index to Contract Drawings see sheet 1

RECORD DRAWING - AS CONSTRUCTED
 CONT. NO. 57-122, REV. B DATE 11-16-66 BY N.P.K.
 CONT. NO. REV. DATE BY

DATUM IS MEAN SEA LEVEL

REV. NO.	DATE	REVISION	REV.	CHK.	APP.
1	4-25-59	Clarified vertical reinforcement parapet wall see Sec. D-D & G. Changed size of bearing pad per addendum #2.			
2	8-17-61	Changed parapet to concrete			

CORPS OF ENGINEERS, U. S. ARMY
 OFFICE OF THE DISTRICT ENGINEER
 LOS ANGELES, CALIFORNIA

SANTA ANA RIVER BASIN, CALIFORNIA
SAN ANTONIO AND CHINO CREEKS IMPROVEMENT
 CHINO CREEK CHANNEL
 CHINO AVENUE TO RAMONA AVENUE
CHINO AVE. BRIDGE
ABUTMENT AND DECK DETAILS

ENGINEER: C.R. AMM.
 DRAWN BY: KEL
 CHECKED BY: J. J. J.
 APPROVED BY: [Signature]
 APPROVAL: [Signature]
 SCALE: AS SHOWN
 DATE: NOVEMBER 1966
 TO ACCOMPANY SPECIFICATIONS CIVENG 04-353-49-21
 SHEET 39 OF 68
 FILE NO. 19 660801 100/59 REV. B*

#1-101-12

Bidder: _____

PROPOSAL

**TO THE BOARD OF SUPERVISORS
OF THE SAN BERNARDINO COUNTY
STATE OF CALIFORNIA**

For Construction On

**PIPELINE AVENUE AND OTHER ROADS
VARIOUS**

LENGTH: 3.09 Mi.

WORK ORDER: H14974

AREA: Chino and Montclair

ROAD NO.: 232050 020-030 & 660850 030-040-050-060

NOTICE: BIDDERS MUST OBTAIN BIDDING DOCUMENTS AND PREPARE THEIR BIDS ON FORMS OBTAINED DIRECTLY FROM THE SAN BERNARDINO COUNTY DEPARTMENT OF PUBLIC WORKS OR FROM THE SAN BERNARDINO COUNTY ELECTRONIC PROCUREMENT NETWORK (ePRO) <https://epro.sbcounty.gov/bsc>. BIDS PREPARED ON FORMS OBTAINED FROM OTHER SOURCES WILL NOT BE ACCEPTED. BIDDERS MUST BE LISTED ON THE OFFICIAL PLAN HOLDERS LIST AT THE TIME BIDS ARE PUBLICLY OPENED. BIDS RECEIVED FROM BIDDERS WHO ARE NOT LISTED ON THE OFFICIAL PLAN HOLDERS LIST WILL NOT BE ACCEPTED.

The undersigned, as bidder, declares that the only persons or parties interested in this proposal as principals are those named herein, that this proposal is made without collusion with any other person, firm, or corporation; that bidder has carefully examined the location of the proposed work, the proposed form of contract, and the plans and specifications therein referred to; and bidder proposes and agrees if this proposal is accepted, that bidder will contract with the San Bernardino County, in the form of the copy of the contract to provide all necessary machinery, tools, apparatus and other means of construction, and to do all work and furnish all the materials specified in the contract, in the manner and in the time therein prescribed, and according to the requirements of the Engineer as therein set forth, and that bidder will take in full payment therefore the following prices, to wit:

PROPOSAL CHECKLIST AND ASSEMBLY SEQUENCE
IMPORTANT

Failure to Properly Complete Bid Package May Result in Rejection of Bid

1

Proposal – Assemble all pages in same numbering sequence as original.

- Replacement Bid Sheets from Addendum are substituted in sequence, if applicable.
- Unit Prices are entered for all bid items (or Alternate bid items).
- Corrections or changes to the bid document are initialed.
- Subcontractors, if any, are listed
- Public Contract Code Section 10285.1 Statement is executed
- Public Contract Code Section 10162 Questionnaire is completed
- Noncollusion Declaration is executed and submitted with bid.
- Bidder Information is completed and correct.
- Proposal is complete and signed by authorized company representative.

2

Addendums, if any, are acknowledged. (Normally sent by facsimile and mail)

- "Bidder's Certification" (Just the Certification page) are executed and attached.

3

Bidder's Security.

- 10% of Bid Amount in Cash, Cashier's Check, Certified Check or Bidder's Bond.
- If Bidder's Bond, surety signature is notarized.
- If Bidder's Bond, surety power of attorney is attached.

4

ePRO.

- Registered as a Vendor in the ePro System prior to date and time to receive bid.
- Bid submitted through ePro, the original Bid Security must submitted in a separate sealed envelope labeled "Bid Bond" with the title of the work and name of bidder marked on outside of envelope to the Department of Public Works, Front Reception. Must be received on or before the time set for the opening of bids.
- For bid submission through ePro, scan and attach to your quote the Fully Executed Proposal Documents (pages P-1 thru P-22).
- Sign and date the "Acknowledgement ePro Process".
- For bid submission through ePro, scan and attach to your quote the fully executed Certification page for ALL Addendums.

5

REGISTERED WITH THE DEPARTMENT OF INDUSTRIAL RELATIONS (DIR) (SENATE BILL 854) & CALIFORNIA AIR RESOURCES BOARD (CARB) IN-USE OFF-ROAD DIESEL-FUEL FLEETS REGULATION COMPLIANCE CERTIFICATION.

- DIR Registration Number and CARB Certificate of Compliance Number identified for Bidder and all subcontractors.

Bidder: _____

ACKNOWLEDGEMENT OF ePro PROCESS

- Bidder is registered as a vendor with San Bernardino County Electronic Procurement Network (ePro) prior to date and time to receive bids.

- Bidder has logged-in to the ePro system with the correct commodity code and downloaded the official bid documents through the ePro system prior to the date and time to receive bids.

- If bidder submits a proposal via ePro, the proposal was uploaded in ePro while logged-in to the ePro system under the bidder's account.

- Bidder confirmed it is listed on the "Official Plan Holders List" by checking on ePro or by calling the County representative at (909) 387-7920 to confirm bidder is on the "Official Plan Holders List" prior to the date and time bids are publicly opened.

- Bidder to submit in person bidder's security and/or proposal in a sealed envelope prior to the proposal opening date and time.

**For system-related issues and technical assistance with ePro, please contact vendor support at ePro.Vendors@buyspeed.com or at (855) 800-5046. For questions involving ePro, such as user accounts, commodity codes, and/or status or placement on the Official Plan Holders List, please contact the Purchasing Department at (909) 387-2060.*

BIDDER'S CERTIFICATION:

By my signature hereunder, I acknowledge I fully understand the above requirements, which I have considered in my preparation of the proposal. I also understand that failure to comply with the above requirements will result in the rejection of bid.

Bidder's Signature

Date

Bidder: _____

Project: **PIPELINE AVENUE AND OTHER ROADS**

W.O.#: **H14974**

Limits: **Various Locations**

Item No.	Approx. Quant.	Meas. Unit	Item Description	Unit Price	Total
1	200,000	F.A.	Supplemental Work At Force Account (Unforeseen Differing Site Conditions, Utility Conflict and Subgrade Stabilization)	\$ 1.00	\$ 200,000.00
2	1	L.S.	Prepare Final Storm Water Pollution Prevention Plan (SWPPP)	\$	\$
3	1	L.S.	Water Pollution Control Work	\$	\$
4	1	L.S.	Mobilization	\$	\$
5	1	L.S.	Clearing and Grubbing	\$	\$
6	1	L.S.	Develop Water Supply	\$	\$
7	1	L.S.	Finishing Roadway	\$	\$
8	1	L.S.	Trench Excavation Safety	\$	\$
9	1	L.S.	Traffic Control System	\$	\$
10	4	EA.	Portable Changeable Message Sign	\$	\$
11	3,260	L.F.	Remove Asphalt Concrete Dike	\$	\$
12	3,155	S.Y.	Remove Asphalt Concrete Surfacing	\$	\$
13	3	EA.	Remove Roadside Sign	\$	\$
14	50	L.F.	Remove Traffic Stripes	\$	\$
15	839	S.F.	Remove Pavement Markings	\$	\$
16	2,165	S.Y.	Remove Concrete (Spandrel, Cross Gutter, Ramp and Sidewalk)	\$	\$
17	1,410	L.F.	Remove Concrete (Curb, Curb and Gutter)	\$	\$
18	25	S.F.	Remove and Dispose Masonry Block Units (At 3672 Chino Avenue and 13285 East End Avenue)	\$	\$
19	39	S.F.	Remove and Relocate Concrete Retaining Wall Blocks (At 11630 Pipeline Avenue)	\$	\$
20	38	L.F.	Remove Existing Chain Link Fence (CLF)	\$	\$
21	14	EA.	Reset Roadside Sign	\$	\$
22	9	EA.	Reset Mailbox	\$	\$
23	18,870	S.Y.	Pulverize Asphalt Concrete Surfacing (1.20' Full Depth)	\$	\$
24	3,470	C.Y.	Export Pulverize Material (0.55' Depth)	\$	\$
25	880	S.Y.	Cold Plane Asphalt Concrete Pavement (0.15' THK)	\$	\$
26	160	S.Y.	Cold Plane Asphalt Concrete Pavement (0.24' THK) - Bridge	\$	\$
27	51,470	S.Y.	Cold Plane Asphalt Concrete Pavement (0.25' THK)	\$	\$
28	1,040	C.Y.	Roadway Excavation	\$	\$
29	1,650	L.F.	Place Asphalt Concrete Dike (8")	\$	\$

Bidder: _____

Project: **PIPELINE AVENUE AND OTHER ROADS**

W.O.#: **H14974**

Limits: **Various Locations**

Item No.	Approx. Quant.	Meas. Unit	Item Description	Unit Price	Total
30	590	L.F.	Place Asphalt Concrete Dike (12")	\$	\$
31	790	L.F.	Place Asphalt Concrete Traversable Dike	\$	\$
32	830	S.Y.	Place Asphalt Concrete (Miscellaneous Area)	\$	\$
33	18,870	S.Y.	2% Cement Treated Base (0.65' THK)	\$	\$
34	840	TON	Asphalt Concrete (Type A, 1/2" Aggregate Gradation, PG 64-10)	\$	\$
35	5,100	TON	Asphalt Concrete (Type A, 3/4" Aggregate Gradation, PG 70-10)	\$	\$
36	310	TON	Asphalt Concrete (Type A, 3/8" Aggregate Gradation, PG 70-10)	\$	\$
37	380	C.Y.	Class 2 Aggregate Base	\$	\$
38	59,360	S.Y.	Asphalt Rubber Binder Seal Coat (3/8" Medium, As Interlayer SAMI PG 64-16)	\$	\$
39	9,090	TON	Rubberized Asphalt Concrete (Type G, 1/2" Aggregate Gradation, PG 64-16)	\$	\$
40	1,800	TON	Rubberized Asphalt Concrete (Type G, 3/4" Aggregate Gradation, PG 64-16)	\$	\$
41	155	C.Y.	Minor Structure (Catch Basin and Monolithic Catch Basin Connection)	\$	\$
42	575	C.Y.	Minor Concrete (Ramp, Spandrel, Curb, Curb and Gutter, Sidewalk, Cross Gutter, Retaining Curb, Driveway and Local Depression)	\$	\$
43	180	S.F.	Concrete Paver	\$	\$
44	792	L.F.	48" Reinforced Concrete Pipe (Class III, 1700D)	\$	\$
45	32	L.F.	36" Reinforced Concrete Pipe (Class III, 1700D)	\$	\$
46	24	L.F.	30" Reinforced Concrete Pipe (Class III, 1350D)	\$	\$
47	80	L.F.	24" Reinforced Concrete Pipe (Class III, 1700D)	\$	\$
48	7	EA.	36" Manhole Frame & Cover	\$	\$
49	9	EA.	Adjust Manhole Frame and Cover to Grade	\$	\$
50	4	EA.	Precast Concrete Manhole Junction Structure (SPPWC Std Plan 320-2)	\$	\$
51	18	S.Y.	Grouted Rock Treatment	\$	\$
52	530	S.F.	ADA Ramp Detectable Warning Surface	\$	\$
53	70	L.F.	Metal Hand Railing	\$	\$
54	35	L.F.	Chain Link Fence (Type CL-4)	\$	\$
55	3	EA.	Roadside Sign	\$	\$
56	6	EA.	Object Marker - Type L-1(CA)(OM2 - 2V)	\$	\$
57	1,513	EA.	Pavement Marker (Retroreflective - Type D & G)	\$	\$
58	25	EA.	Pavement Marker (Retroreflective - Blue)	\$	\$

Bidder: _____

Project: **PIPELINE AVENUE AND OTHER ROADS**

W.O.#: **H14974**

Limits: **Various Locations**

Item No.	Approx. Quant.	Meas. Unit	Item Description	Unit Price	Total
59	28,730	L.F.	Paint 6" wide Traffic Stripe (2-Coat)	\$	\$
60	1,670	L.F.	Paint 8" wide Traffic Stripe (2-Coat)	\$	\$
61	13,870	L.F.	Paint Double 6" wide Traffic Stripe (2-Coat)	\$	\$
62	6,933	S.F.	Paint Pavement Marking (2-Coat)	\$	\$
63	1	L.S.	(F) UPRR Administrative Fee	\$	\$
64	1	L.S.	Signals and Lighting	\$	\$
65	78	EA.	Inductive Loop Detector	\$	\$

PROJECT TOTAL: \$

NOT FOR BID

Bids are to be submitted for the entire work. The amount of the bid for comparison purposes will be the total of all items.

The bidder shall set forth for each unit basis item of work a unit price and a total for the item, and for each lump sum item a total for the item, all in clearly legible figures in the respective spaces provided for this purpose. In the case of unit basis items, the amount set forth under the "Total" column shall be the extension of the unit price bid on the basis of the estimated quantity for the item.

In case of discrepancy between the unit price and the total set forth for a unit basis item, the unit price shall prevail, however, if the amount set forth as a unit price is ambiguous, unintelligible or uncertain for any cause, or is omitted, then the amount set forth in the "Total" column for the item shall prevail and shall be divided by the estimated quantity for the item and the price thus obtained, rounded to the next lower penny, shall be the unit price.

If this proposal shall be accepted, the contract shall be signed by the successful bidder and returned **within 10 days**, and the contract bonds, copy of insurance policies, and Certificates of Insurance, with documents to verify any self-insurance coverage shall be provided **within 10 days**, not including Saturdays, Sundays and legal holidays, after the bidder has received the contract for execution. Should the undersigned fail to contract as aforesaid, the Board of Supervisors may, at its option, determine that the bidder has abandoned the contract, and, thereupon, this proposal and the acceptance thereof shall be null and void, and the forfeiture of such security accompanying this proposal shall operate and the same may be the property of the San Bernardino County.

NOT FOR BID

NOTE: THIS FORM MUST BE COMPLETED, SIGNED AND RETURNED WITH THE PROPOSAL

BIDDER _____

The bidder shall complete the following information as required by the Subletting and Subcontracting Fair Practices Act, Public Contract Code section 4100 et seq.

Note: Subcontractors must be licensed and registered with the DIR (with limited exceptions from this requirement for bid purposes only under Labor Code section 1771.1(a)) at the time of the bid opening.

Information marked with ** is required. (Make additional copies of this form if needed)

SUBCONTRACTORS LIST

Name: ** _____ Fed. ID: _____ Item(s) #: ** _____

Business Location: ** _____ % (s): _____

Telephone: () _____ Amount: \$ _____

License #: ** _____ Description of Work: ** _____

DIR Registration #: ** _____ CARB Certificate of Compliance #: ** _____

Name: ** _____ Fed. ID: _____ Item(s) #: ** _____

Business Location: ** _____ % (s): _____

Telephone: () _____ Amount: \$ _____

License #: ** _____ Description of Work: ** _____

DIR Registration #: ** _____ CARB Certificate of Compliance #: ** _____

Name: ** _____ Fed. ID: _____ Item(s) #: ** _____

Business Location: ** _____ % (s): _____

Telephone: () _____ Amount: \$ _____

License #: ** _____ Description of Work: ** _____

DIR Registration #: ** _____ CARB Certificate of Compliance #: ** _____

Name: ** _____ Fed. ID: _____ Item(s) #: ** _____

Business Location: ** _____ % (s): _____

Telephone: () _____ Amount: \$ _____

License #: ** _____ Description of Work: ** _____

DIR Registration #: ** _____ CARB Certificate of Compliance #: ** _____

NOTE: THIS FORM MUST BE COMPLETED, SIGNED AND RETURNED WITH THE PROPOSAL

PUBLIC CONTRACT CODE SECTION 10232 STATEMENT

In accordance with Public Contract Code section 10232, the Contractor hereby states, under penalty of perjury, that no more than one final unappealable finding of contempt of court by a federal court has been issued against the Contractor within the immediately preceding two year period because of the Contractor's failure to comply with an order of a federal court which orders the Contractor to comply with an order of the National Labor Relations Board.

PUBLIC CONTRACT CODE SECTION 10285.1 STATEMENT

In accordance with Public Contract Code section 10285.1, the bidder hereby declares under penalty of perjury that the bidder

has Check One has not

been convicted within the preceding three years of any offenses referred to in that section, including any charge of fraud, bribery, collusion, conspiracy, or any other act in violation of any state or federal antitrust law in connection with the bidding upon, award of, or performance of, any public works contract, as defined in Public Contract Code section 1101, with any public entity, as defined in Public Contract Code section 1100, including the Regents of the University of California or the Trustees of the California State University. The term "bidder" is understood to include any partner, member, officer, director, responsible managing officer, or responsible managing employee thereof, as referred to in Section 10285.1.

Note: The bidder must place a check mark after "has" or "has not" in one of the blank spaces provided.

The above Statements are part of the Proposal. Signing this Proposal on the signature portion thereof shall also constitute signature of these Statements.

Bidders are cautioned that making a false certification may subject the certifier to criminal prosecution.

NOTE: THIS FORM MUST BE COMPLETED, SIGNED AND RETURNED WITH THE PROPOSAL

PUBLIC CONTRACT CODE SECTION 10162 QUESTIONNAIRE

In accordance with Public Contract Code section 10162, the Bidder shall complete, under penalty of perjury, the following questionnaire:

Has the bidder, any officer of the bidder, or any employee of the bidder who has a proprietary interest in the bidder, ever been disqualified, removed, or otherwise prevented from bidding on, or completing a federal, state, or local government project because of a violation of law or a safety regulation?

Check One

Yes

No

If the answer is yes, explain the circumstances in the following space.

NOTE: The above Questionnaire is part of the Proposal. Signing this Proposal on the signature portion thereof shall also constitute signature of this Questionnaire.
Bidders are cautioned that making a false certification may subject the certifier to criminal prosecution.

PUBLIC CONTRACT CODE
SECTIONS 9204, 20104, 20104.2, 20104.4, 20104.6, AND 20104.50
RESOLUTION OF CONSTRUCTION CLAIMS AND PROMPT PAYMENT

9204

(a) The Legislature finds and declares that it is in the best interests of the state and its citizens to ensure that all construction business performed on a public works project in the state that is complete and not in dispute is paid in full and in a timely manner.

(b) Notwithstanding any other law, including, but not limited to, Article 7.1 (commencing with Section 10240) of Chapter 1 of Part 2, Chapter 10 (commencing with Section 19100) of Part 2, and Article 1.5 (commencing with Section 20104) of Chapter 1 of Part 3, this section shall apply to any claim by a contractor in connection with a public works project.

(c) For purposes of this section:

(1) "Claim" means a separate demand by a contractor sent by registered mail or certified mail with return receipt requested, for one or more of the following:

(A) A time extension, including, without limitation, for relief from damages or penalties for delay assessed by a public entity under a contract for a public works project.

(B) Payment by the public entity of money or damages arising from work done by, or on behalf of, the contractor pursuant to the contract for a public works project and payment for which is not otherwise expressly provided or to which the claimant is not otherwise entitled.

(C) Payment of an amount that is disputed by the public entity.

(2) "Contractor" means any type of contractor within the meaning of Chapter 9 (commencing with Section 7000) of Division 3 of the Business and Professions Code who has entered into a direct contract with a public entity for a public works project.

(3) (A) "Public entity" means, without limitation, except as provided in subparagraph (B), a state agency, department, office, division, bureau, board, or commission, the California State University, the University of California, a city, including a charter city, county, including a charter county, city and county, including a charter city and county, district, special district, public authority, political subdivision, public corporation, or nonprofit transit corporation wholly owned by a public agency and formed to carry out the purposes of the public agency.

(B) "Public entity" shall not include the following:

(i) The Department of Water Resources as to any project under the jurisdiction of that department.

(ii) The Department of Transportation as to any project under the jurisdiction of that department.

(iii) The Department of Parks and Recreation as to any project under the jurisdiction of that department.

(iv) The Department of Corrections and Rehabilitation with respect to any project under its jurisdiction pursuant to Chapter 11 (commencing with Section 7000) of Title 7 of Part 3 of the Penal Code.

(v) The Military Department as to any project under the jurisdiction of that department.

(vi) The Department of General Services as to all other projects.

(vii) The High-Speed Rail Authority.

(4) "Public works project" means the erection, construction, alteration, repair, or improvement of any public structure, building, road, or other public improvement of any kind.

(5) "Subcontractor" means any type of contractor within the meaning of Chapter 9 (commencing with Section 7000) of Division 3 of the Business and Professions Code who either is in direct contract with a contractor or is a lower tier subcontractor.

(d) (1) (A) Upon receipt of a claim pursuant to this section, the public entity to which the claim applies shall conduct a reasonable review of the claim and, within a period not to exceed 45 days, shall provide the claimant a written statement identifying what portion of the claim is disputed and what portion is undisputed. Upon receipt of a claim, a public entity and a contractor may, by mutual agreement, extend the time period provided in this subdivision.

(B) The claimant shall furnish reasonable documentation to support the claim.

(C) If the public entity needs approval from its governing body to provide the claimant a written statement identifying the disputed portion and the undisputed portion of the claim, and the governing body does not meet within the 45 days or within the mutually agreed to extension of time following receipt of a claim sent by registered mail or certified mail, return receipt requested, the public entity shall have up to three days following the next duly publicly noticed meeting of the governing body after the 45-day period, or extension, expires to provide the claimant a written statement identifying the disputed portion and the undisputed portion.

(D) Any payment due on an undisputed portion of the claim shall be processed and made within 60 days after the public entity issues its written statement. If the public entity fails to issue a written statement, paragraph (3) shall apply.

(2) (A) If the claimant disputes the public entity's written response, or if the public entity fails to respond to a claim issued pursuant to this section within the time prescribed, the claimant may demand in writing an informal conference to meet and confer for settlement of the issues in dispute. Upon receipt of a demand in writing sent by registered mail or certified mail, return receipt requested, the public entity shall schedule a meet and confer conference within 30 days for settlement of the dispute.

(B) Within 10 business days following the conclusion of the meet and confer conference, if the claim or any portion of the claim remains in dispute, the public entity shall provide the claimant a written statement identifying the portion of the claim that remains in dispute and the portion that is undisputed. Any payment due on an undisputed portion of the claim shall be processed and made within 60 days after the public entity issues its written statement. Any disputed portion of the claim, as identified by the contractor in writing, shall be submitted to nonbinding mediation, with the public entity and the claimant sharing the associated costs equally. The

public entity and claimant shall mutually agree to a mediator within 10 business days after the disputed portion of the claim has been identified in writing. If the parties cannot agree upon a mediator, each party shall select a mediator and those mediators shall select a qualified neutral third party to mediate with regard to the disputed portion of the claim. Each party shall bear the fees and costs charged by its respective mediator in connection with the selection of the neutral mediator. If mediation is unsuccessful, the parts of the claim remaining in dispute shall be subject to applicable procedures outside this section.

(C) For purposes of this section, mediation includes any nonbinding process, including, but not limited to, neutral evaluation or a dispute review board, in which an independent third party or board assists the parties in dispute resolution through negotiation or by issuance of an evaluation. Any mediation utilized shall conform to the timeframes in this section.

(D) Unless otherwise agreed to by the public entity and the contractor in writing, the mediation conducted pursuant to this section shall excuse any further obligation under Section 20104.4 to mediate after litigation has been commenced.

(E) This section does not preclude a public entity from requiring arbitration of disputes under private arbitration or the Public Works Contract Arbitration Program, if mediation under this section does not resolve the parties' dispute.

(3) Failure by the public entity to respond to a claim from a contractor within the time periods described in this subdivision or to otherwise meet the time requirements of this section shall result in the claim being deemed rejected in its entirety. A claim that is denied by reason of the public entity's failure to have responded to a claim, or its failure to otherwise meet the time requirements of this section, shall not constitute an adverse finding with regard to the merits of the claim or the responsibility or qualifications of the claimant.

(4) Amounts not paid in a timely manner as required by this section shall bear interest at 7 percent per annum.

(5) If a subcontractor or a lower tier subcontractor lacks legal standing to assert a claim against a public entity because privity of contract does not exist, the contractor may present to the public entity a claim on behalf of a subcontractor or lower tier subcontractor. A subcontractor may request in writing, either on his or her own behalf or on behalf of a lower tier subcontractor, that the contractor present a claim for work which was performed by the subcontractor or by a lower tier subcontractor on behalf of the subcontractor. The subcontractor requesting that the claim be presented to the public entity shall furnish reasonable documentation to support the claim. Within 45 days of receipt of this written request, the contractor shall notify the subcontractor in writing as to whether the contractor presented the claim to the public entity and, if the original contractor did not present the claim, provide the subcontractor with a statement of the reasons for not having done so.

(e) The text of this section or a summary of it shall be set forth in the plans or specifications for any public works project that may give rise to a claim under this section.

(f) A waiver of the rights granted by this section is void and contrary to public policy, provided, however, that (1) upon receipt of a claim, the parties may mutually agree to waive, in writing, mediation and proceed directly to the commencement of a civil action or binding arbitration, as applicable; and (2) a public entity may prescribe reasonable change order, claim, and dispute

resolution procedures and requirements in addition to the provisions of this section, so long as the contractual provisions do not conflict with or otherwise impair the timeframes and procedures set forth in this section.

(g) This section applies to contracts entered into on or after January 1, 2017.

(h) Nothing in this section shall impose liability upon a public entity that makes loans or grants available through a competitive application process, for the failure of an awardee to meet its contractual obligations.

(i) This section shall remain in effect only until January 1, 2020, and as of that date is repealed, unless a later enacted statute, that is enacted before January 1, 2020, deletes or extends that date.

20104.

(a)(1) This article applies to all public works claims of three hundred seventy-five thousand dollars (\$375,000) or less which arise between a contractor and a local agency.

(2) This article shall not apply to any claims resulting from a contract between a contractor and a public agency when the public agency has elected to resolve any disputes pursuant to Article 7.1 (commencing with Section 10240) of Chapter 1 of Part 2.

(b)(1) "Public work" means "public works contract" as defined in Section 1101 but does not include any work or improvement contracted for by the state or the Regents of the University of California.

(2) "Claim" means a separate demand by the contractor for (A) a time extension, (B) payment of money or damages arising from work done by, or on behalf of, the contractor pursuant to the contract for a public work and payment of which is not otherwise expressly provided for or the claimant is not otherwise entitled to, or (C) an amount the payment of which is disputed by the local agency.

(c) The provisions of this article or a summary thereof shall be set forth in the plans or specifications for any work which may give rise to a claim under this article.

(d) This article applies only to contracts entered into on or after January 1, 1991.

20104.2 For any claim subject to this article, the following requirements apply:

(a) The claim shall be in writing and include the documents necessary to substantiate the claim. Claims must be filed on or before the date of final payment. Nothing in this subdivision is intended to extend the time limit or supersede notice requirements otherwise provided by contract for the filing of claims.

(b)(1) For claims of less than fifty thousand dollars (\$50,000), the local agency shall respond in writing to any written claim within 45 days of receipt of the claim, or may request, in writing, within 30 days of receipt of the claim, any additional documentation supporting the claim or relating to defenses to the claim the local agency may have against the claimant.

(2) If additional information is thereafter required, it shall be requested and provided pursuant to this subdivision, upon mutual agreement of the local agency and the claimant.

(3) The local agency's written response to the claim, as further documented, shall be submitted to the claimant within 15 days after receipt of the further documentation or within a period of time no greater than that taken by the claimant in producing the additional information, whichever is greater.

(c)(1) For claims of over fifty thousand dollars (\$50,000) and less than or equal to three hundred seventy-five thousand dollars (\$375,000), the local agency shall respond in writing to all written claims within 60 days of receipt of the claim, or may request, in writing, within 30 days of receipt of the claim, any additional documentation supporting the claim or relating to defenses to the claim the local agency may have against the claimant.

(2) If additional information is thereafter required, it shall be requested and provided pursuant to this subdivision, upon mutual agreement of the local agency and the claimant.

(3) The local agency's written response to the claim, as further documented, shall be submitted to the claimant within 30 days after receipt of the further documentation, or within a period of time no greater than that taken by the claimant in producing the additional information or requested documentation, whichever is greater.

(d) If the claimant disputes the local agency's written response, or the local agency fails to respond within the time prescribed, the claimant may so notify the local agency, in writing, either within 15 days of receipt of the local agency's response or within 15 days of the local agency's failure to respond within the time prescribed, respectively, and demand an informal conference to meet and confer for settlement of the issues in dispute. Upon a demand, the local agency shall schedule a meet and confer conference within 30 days for settlement of the dispute.

(e) Following the meet and confer conference, if the claim or any portion remains in dispute, the claimant may file a claim as provided in Chapter 1 (commencing with Section 900) and Chapter 2 (commencing with Section 910) of Part 3 of Division 3.6 of Title 1 of the Government Code. For purposes of those provisions, the running of the period of time within which a claim must be filed shall be tolled from the time the claimant submits his or her written claim pursuant to subdivision (a) until the time that claim is denied as a result of the meet and confer process, including any period of time utilized by the meet and confer process.

(f) This article does not apply to tort claims and nothing in this article is intended nor shall be construed to change the time periods for filing tort claims or actions specified by Chapter 1 (commencing with Section 900) and Chapter 2 (commencing with Section 910) of Part 3 of Division 3.6 of Title 1 of the Government Code.

20104.4 The following procedures are established for all civil actions filed to resolve claims subject to this article:

(a) Within 60 days, but no earlier than 30 days, following the filing or responsive pleadings, the court shall submit the matter to nonbinding mediation unless waived by mutual stipulation of both parties. The mediation process shall provide for the selection within 15 days by both parties of a disinterested third person as mediator, shall be commenced within 30 days of the

submittal, and shall be concluded within 15 days from the commencement of the mediation unless a time requirement is extended upon a good cause showing to the court or by stipulation of both parties. If the parties fail to select a mediator within the 15-day period, any party may petition the court to appoint the mediator.

(b)(1) If the matter remains in dispute, the case shall be submitted to judicial arbitration pursuant to Chapter 2.5 (commencing with Section 1141.10) of Title 3 of Part 3 of the Code of Civil Procedure, notwithstanding Section 1141.11 of that code. The Civil Discovery Act (Title 4 (commencing with Section 2016.10) of Part 4 of the Code of Civil Procedure) shall apply to any proceeding brought under this subdivision consistent with the rules pertaining to judicial arbitration.

(2) Notwithstanding any other provision of law, upon stipulation of the parties, arbitrators appointed for purposes of this article shall be experienced in construction law, and, upon stipulation of the parties, mediators and arbitrators shall be paid necessary and reasonable hourly rates of pay not to exceed their customary rate, and such fees and expenses shall be paid equally by the parties, except in the case of arbitration where the arbitrator, for good cause, determines a different division. In no event shall these fees or expenses be paid by state or county funds.

(3) In addition to Chapter 2.5 (commencing with Section 1141.10) of Title 3 of Part 3 of the Code of Civil Procedure, any party who after receiving an arbitration award requests a trial de novo but does not obtain a more favorable judgment shall, in addition to payment of costs and fees under that chapter, pay the attorney's fees of the other party arising out of the trial de novo.

(c) The court may, upon request by any party, order any witnesses to participate in the mediation or arbitration process.

20104.6

(a) No local agency shall fail to pay money as to any portion of a claim which is undisputed except as otherwise provided in the contract.

(b) In any suit filed under Section 20104.4, the local agency shall pay interest at the legal rate on any arbitration award or judgment. The interest shall begin to accrue on the date the suit is filed in a court of law.

ARTICLE 1.7

Modification; Performance, Payment

20104.50

(a) (1) It is the intent of the Legislature in enacting this section to require all local governments to pay their contractors on time so that these contractors can meet their own obligations. In requiring prompt payment by all local governments, the Legislature hereby finds and declares that the prompt payment of outstanding receipts is not merely a municipal affair, but is, instead, a matter of statewide concern.

(2) It is the intent of the Legislature in enacting this article to fully occupy the field of public policy relating to the prompt payment of local governments' outstanding receipts. The Legislature finds and declares that all government officials, including those in local government, must set a standard of prompt payment that any business in the private sector which may contract for services should look towards for guidance.

(b) Any local agency which fails to make any progress payment within 30 days after receipt of an undisputed and properly submitted payment request from a contractor on a construction contract shall pay interest to the contractor equivalent to the legal rate set forth in subdivision (a) of Section 685.010 of the Code of Civil Procedure.

(c) Upon receipt of a payment request, each local agency shall act in accordance with both of the following:

(1) Each payment request shall be reviewed by the local agency as soon as practicable after receipt for the purpose of determining that the payment request is a proper payment request.

(2) Any payment request determined not to be a proper payment request suitable for payment shall be returned to the contractor as soon as practicable, but not later than seven days, after receipt. A request returned pursuant to this paragraph shall be accompanied by a document setting forth in writing the reasons why the payment request is not proper.

(d) The number of days available to a local agency to make a payment without incurring interest pursuant to this section shall be reduced by the number of days by which a local agency exceeds the seven-day return requirement set forth in paragraph (2) of subdivision (c).

(e) For purposes of this article:

(1) A "local agency" includes, but is not limited to, a city, including a charter city, a county, and a city and county, and is any public entity subject to this part.

(2) A "progress payment" includes all payments due contractors, except that portion of the final payment designated by the contract as retention earnings.

(3) A payment request shall be considered properly executed if funds are available for payment of the payment request, and payment is not delayed due to an audit inquiry by the financial officer of the local agency.

(f) Each local agency shall require that this article, or a summary thereof, be set forth in the terms of any contract subject to this article.

NOTE: THIS FORM MUST BE COMPLETED, SIGNED AND RETURNED WITH THE PROPOSAL

**NONCOLLUSION DECLARATION
TO BE EXECUTED BY BIDDER AND SUBMITTED WITH BID**

(Public Contract Code section 7106)

The undersigned declares:

I am the _____ [title] of _____ [name of the bidder], the party making the foregoing bid.

The bid is not made in the interest of, or on behalf of, any undisclosed person, partnership, company, association, organization, or corporation. The bid is genuine and not collusive or sham. The bidder has not directly or indirectly induced or solicited any other bidder to put in a false or sham bid. The bidder has not directly or indirectly colluded, conspired, connived, or agreed with any bidder or anyone else to put in a sham bid, or to refrain from bidding. The bidder has not in any manner, directly or indirectly, sought by agreement, communication, or conference with anyone to fix the bid price of the bidder or any other bidder, or to fix any overhead, profit, or cost element of the bid price, or of that of any other bidder. All statements contained in the bid are true. The bidder has not, directly or indirectly, submitted his or her bid price or any breakdown thereof, or the contents thereof, or divulged information or data relative thereto, to any corporation, partnership, company, association, organization, bid depository, or to any member or agent thereof, to effectuate a collusive or sham bid, and has not paid, and will not pay, any person or entity for such purpose.

Any person executing this declaration on behalf of a bidder that is a corporation, partnership, joint venture, limited liability company, limited liability partnership, or any other entity, hereby represents that he or she has full power to execute, and does execute, this declaration on behalf of the bidder.

I declare under penalty of perjury under the laws of the State of California that the foregoing is true and correct and that this declaration is executed on

_____ [date], at _____ [city], _____ [state].

Print Name

Signature - REQUIRED

NOTE: The above Noncollusion Declaration is part of the Bid, and failure to include the Noncollusion Declaration with the Bid will result in the Bid being found nonresponsive.

Bidders are reminded that this declaration must be signed under penalty of perjury.

If the bid proposal is submitted through ePro the undersigned acknowledges that its electronic signature is legally binding.

**IRAN CONTRACTING ACT OF 2010
(Public Contract Code section 2200 et seq.)**

(Applicable only to Contracts of One Million Dollars (\$1,000,000) or More):

In accordance with Public Contract Code section 2204 (a), the bidder certifies that at the time the bid is submitted or the contract is renewed, that bidder is not identified on a list created pursuant to subdivision (b) of Public Contract Code section 2203 as a person engaging in investment activities in Iran described in subdivision (a) of Public Contract Code section 2202.5, or as a person described in subdivision (b) of Public Contract Code section 2202.5, as applicable. A state agency shall submit the certification information to the Department of General Services.

RUSSIAN SANCTION/EXECUTIVE ORDER N-6-22

(Applicable for all Contracts of five million dollars (\$5,000,000) or more utilizing State funding.):

On March 4, 2022, Governor Gavin Newsom issued Executive Order N-6-22 (the EO) regarding Economic Sanctions against Russia and Russian entities and individuals. "Economic Sanctions" refers to sanctions imposed by the U.S. government in response to Russia's actions in Ukraine (<https://home.treasury.gov/policy-issues/financial-sanctions/sanctions-programs-and-country-information/ukraine-russia-related-sanctions>), as well as any sanctions imposed under state law (<https://www.dgs.ca.gov/OLS/Ukraine-Russia>). The EO directs state agencies and their contractors (including by agreement or receipt of a grant) to terminate contracts with, and to refrain from entering any new contracts with, individuals or entities that are determined to be a target of Economic Sanctions. Accordingly, should it be determined that Contractor is a target of Economic Sanctions or is conducting prohibited transactions with sanctioned individuals or entities, that shall be grounds for termination of this agreement. Contractor shall be provided advance written notice of such termination, allowing Contractor at least 30 calendar days to provide a written response. Termination shall be at the sole discretion of the County.

NOTE: The above Certification is part of the Proposal. Signing this Proposal on the signature portion thereof shall also constitute signature of this Certification.

Bidders are cautioned that making a false certification may subject bidder to civil penalties, termination of existing contract, and ineligibility to bid on a contract for a period of three (3) years in accordance with Public Contract Code section 2205.

NOTE: THIS FORM MUST BE COMPLETED, SIGNED AND RETURNED WITH THE PROPOSAL

Accompanying this proposal is _____
in the amount equal to at least ten percent of the total of the bid.

(Note: Insert the words "CASH (\$)," "CASHIER'S CHECK," "CERTIFIED CHECK," or "BIDDER'S BOND," as the case may be.)

The names of all persons interested in the foregoing proposal as principals are as follows:

NOTICE: If the bidder or other interested person is a corporation, state legal name of corporation, also names of the president, secretary, treasurer, and manager thereof; if a co-partnership, state true name of firm, also names of all individual co-partners composing firm; if bidder or other interested person is an individual, state first and last names in full.

Licensed in accordance with an act providing for the registration of Contractors,

License No.: _____ Expiration Date: _____

Dept. of Industrial Relations Reg. No: _____ Federal Identification No.: _____

By my signature on this proposal I certify, under penalty of perjury under the laws of the State of California, that the foregoing documents are true and correct and that the bidder satisfies all of the requirements identified in said documents.

If the bid proposal is submitted through ePro the undersigned acknowledges that its electronic signature is legally binding.

<u>Print Name</u>	<u>Signature - REQUIRED</u>	<u>Title</u>
_____	_____	_____
_____	_____	_____
_____	_____	_____
_____	_____	_____

Date: _____

Name of Bidder _____

Business Address _____

Place of Business _____

Business Phone No. _____ Business Fax No. _____

Place of Residence _____

BID BOND

KNOW ALL MEN BY THESE PRESENTS:

That we, _____

_____, as Principal, (hereinafter called the "Principal"),

and _____, as Surety, (hereinafter called "Surety"),

an admitted Surety insurer pursuant to Code of Civil Procedure, Section 995.120, legally doing business in California at:

are held and firmly bound unto the **SAN BERNARDINO COUNTY**, as Obligee, (hereinafter called "**Obligee**"), in the sum of

_____ Dollars (\$ _____),

for the payment of which sum well and truly to be made, the said Principal and the said Surety, bind ourselves, our heirs, executors, administrators, successors and assigns, jointly and severally firmly by these presents.

WHEREAS, the Principal has submitted a bid for:

**PROJECT TITLE: PIPELINE AVENUE AND OTHER ROADS;
PROJECT LIMITS: VARIOUS;
W. O. NO.: H14974**

BID DATE: _____

NOW, THEREFORE, if the Obligee shall accept the bid of the Principal and the Principal shall enter into a contract with the Obligee in accordance with the terms of said proposal and give such bonds as may be specified in the bidding or contract documents with good and sufficient surety for the faithful performance of such contract and for the prompt payment of labor and material furnished in the prosecution thereof, or in the event of the failure of the Principal to enter into such contract and give such bonds, if the Principal shall pay to the Obligee the difference not to exceed the penalty hereof between the amount specified in said bid and such larger amount for which the Obligee may in good faith contract with another party to perform the work covered by said bid, then this obligation shall be null and void, otherwise to remain in full force and effect.

Signed and sealed this _____ day of _____, _____ Year

Principal

Surety

By: _____
Signature

By: _____
Signature, Attorney-in-Fact

Printed Name

Printed Name

Title

**CONTRACTOR CERTIFICATION
CALIFORNIA AIR RESOURCES BOARD (CARB)**

IN-USE OFF-ROAD DIESEL FUELED FLEET CERTIFICATION OF COMPLIANCE

I hereby certify that Contractor is familiar with the requirements of California Code of Regulations (CCR) Title 13 sections 2449, 2449.1, and 2449.2, In-Use Off-Road Diesel Fueled Fleet Regulation (Off-Road Regulation) Compliance (CARB), and that Contractor shall comply with these requirements:

1. Certification of Compliance. I hereby certify that I and all of my subcontractors will conform to the California Air Resource Board ("CARB") In-Use Off-Road Diesel-Fueled Fleets requirements for all work involving the use of vehicles subject to the regulations, including, without limitation, as applicable, the Contracting Requirements in Title 13 CCR section 2449, subdivision (i), subparts (1) – (4), and the Prime Contractor Requirements in Title 13 CCR section 2449, subdivision (j), subparts (1) – (5).

2. Instructions. Check one (1) box below.

Contractor's current CARB issued Certificate of Reported Compliance accompanies this Certification. (If this box is checked, the valid Certificate(s) Reported Compliance with this Regulation for In-Use Off-Road Diesel-Fueled Fleet provided by CARB for the fleet selected for the contract and their listed subcontractors, if applicable **must** be provided with this form.)

Contractor certifies that its work on the Project (including work of its Subcontractors) does not involve the use of vehicles subject to the CARB In-Use Off-Road Diesel-Fueled Fleets requirements.

3. I further certify that each of the Contractor's listed subcontractors is familiar with these requirements and shall also comply.

***Note:** All Subcontractor(s) Certificate of Reported Compliance Number(s) shall be listed on the Designation of Subcontractors form.

Failure to submit this form or comply with any of the above requirements may result in the bid to be found non-responsive. Bidder shall ensure that their fleet, as well as all rental fleets and subcontractor fleets, maintain their active and current CARB certification for the duration of the project.

The Bidder certifies under penalty of perjury under the laws of the State of California that the information provided in this form is true and correct.

Bidder's Company Name: _____

Signature: _____ Title: _____

Print Name: _____ Date: _____



Contract Number

SAP Number

PUBLIC WORKS

Department Contract Representative _____
Telephone Number _____

Contractor _____
Contractor Representative _____
Telephone Number _____
Contract Term _____
Original Contract Amount _____
Amendment Amount _____
Total Contract Amount _____
Cost Center _____

IT IS HEREBY AGREED AS FOLLOWS:

(Use space below and additional bond sheets. Set forth service to be rendered, amount to be paid, manner of payment, time for performance or completion, determination of satisfactory performance and cause for termination, other terms and conditions, and attach plans, specifications, and addenda, if any.)

ARTICLE I. That for and in consideration of payment and agreements hereinafter mentioned to be made and performed by County, and under the conditions expressed in the two bonds, hereunto annexed, Contractor agrees with County, at Contractor's own proper cost and expense to do all the work and to furnish all the materials necessary to construct and complete in a good, workmanlike and substantial manner, this project to the satisfaction of the Director of Public Works in accordance with the following documents, which are incorporated herein by this reference, and the articles set out below:

Plans entitled: Plans for Construction on PIPELINE AVENUE AND OTHER ROADS VARIOUS, Chino and Montclair area, Work Order No.: H14974; Road No.: 232050 020-030 & 660850 030-040-050-060.

California Department of Transportation (Caltrans) 2015 Standard Specifications and the 2018 Standard Plans, including the Caltrans 2015 Revised Standard Specifications (Revisions through July 21, 2017) and the 2018 Revised Standard Plans (Revisions through October 15, 2021), unless specified otherwise in the contract documents.

Special Provisions entitled: Special Provisions for Construction on PIPELINE AVENUE AND OTHER ROADS VARIOUS; Length: 3.09 Mi.; Work Order No.: H14974; Area: Chino and Montclair; Road No.: 232050 020-030 & 660850 030-040-050-060.

ARTICLE II. Contractor agrees to receive and accept the following prices as full compensation for furnishing all materials and for doing all the work contemplated and embraced in this agreement; also for all loss or damage arising out of the nature of the work aforesaid, or from the action of the elements, or from any unforeseen difficulties or obstructions which may arise or be encountered in the prosecution of the work, until its acceptance by the County, and for all risks of every description connected with the work; also for expenses incurred by or in consequence of the suspension or discontinuance of work and for well and faithfully completing the work, and the whole thereof, in the manner and according to the plans and specifications, and the requirements of the Engineer under them, to wit:

Project: _____

W.O. #: _____

Limits: _____

Item No.	Approx. Quant.	Meas. Unit	Item Description	Unit Price	Total
----------	----------------	------------	------------------	------------	-------

Table of Contract Quantities, Items and Prices will be shown here

NOT FOR BID

ARTICLE III. County hereby promises and agrees with Contractor to employ and does hereby employ Contractor to provide the materials and to do the work according to the terms and conditions herein contained and referred to, for the prices aforesaid, and thereby contracts to pay the same at the time, in the manner and upon conditions above set forth, and said parties hereto for themselves, their heirs, executors, administrators, successors and assigns do hereby agree to the full performance of the covenants herein contained.

ARTICLE IV. Contractor shall accept all payments from County via electronic funds transfer (EFT) directly deposited into the Contractor's designated checking or other banking account. Contractor shall promptly comply with directions and accurately complete forms provided by County required to process EFT payments.

ARTICLE V. Contractor may, upon written request and at their expense, deposit substitute securities found in Government Code Section 16430 as authorized by Public Contract Code Section 22300 in lieu of retention monies withheld to insure performance.

ARTICLE VI. It is further expressly agreed by and between the parties hereto that, should there be any conflict between the terms of this instrument and the bid or proposal of said Contractor, then this instrument shall control and nothing herein shall be considered as an acceptance of the said terms of said proposal conflicting herewith.

ARTICLE VII. During the term of the Contract, Contractor shall not discriminate against any employee or applicant for employment because of race, religious creed, color, national origin, ancestry, physical disability, mental disability, medical condition, genetic information, marital status, sex, gender, gender identity, gender expression, sexual orientation, age, or military and veteran status. Contractor shall comply with Executive Orders 11246, 11375, 11625, 12138, 12432, 12250, Title VI and VII of the Civil Rights Act of 1964, the California Fair Housing and Employment Act, County Policy and other applicable federal, state and County laws, regulations and policies relating to equal employment and contracting opportunities, including laws and regulations hereafter enacted.

ARTICLE VIII. Contractor shall comply with the provisions found in Exhibit "A," entitled, "Prevailing Wage Requirements, Required Contract Provisions [Federal Form 1273] Federal-Aid Construction Contracts, Female and Minority Goals, and Federal Trainee Program," attached to this Contract and incorporated herein by this reference.

ARTICLE IX. By my signature hereunder, as Contractor, I certify that I am aware of the provisions of Section 3700 of the Labor Code which requires every employer to be insured against liability for Workers Compensation or to undertake self-insurance in accordance with the provisions of that code, and I will comply with such provisions before commencing the performance of the work of this contract.

ARTICLE X. By my signature hereunder, as Contractor, I certify that I am aware of the provisions and requirements of Sections 1777.5 and 1777.7 of the Labor Code relating to apprenticeship standards; and that I accept responsibility for compliance with the provisions of Section 1777.5 for all apprenticeable occupations pertaining to performance of work under this contract.

ARTICLE XI. By my signature hereunder, as Contractor, I agree that County has the right to review, obtain and copy all records pertaining to performance of the contract. I agree to provide County with any relevant information requested and shall permit County access to company's premises upon reasonable notice for purposes on interviewing employees and inspecting records. I shall maintain all project records for at least three (3) years after final payment under the contract.

ARTICLE XII. Contractor shall comply with the Prevailing Wage Laws described in this Agreement, including Exhibit A.

As required by Labor Code section 1771.1(a) "A contractor or subcontractor shall not be qualified to bid on, be listed in a bid proposal, subject to the requirements of Section 4104 of the Public Contract Code, or engage in the performance of any contract for public work, as defined in this chapter, unless currently registered and qualified to perform public work pursuant to Section 1725.5. It is not a violation of this section for an unregistered contractor to submit a bid that is authorized by Section 7029.1 of the Business and Professions Code or by Section 10164 or 20103.5 of the Public Contract Code, provided the contractor is registered to perform public work pursuant to Section 1725.5 at the time the contract is awarded."

ARTICLE XIII. Contractor agrees:

(1) To utilize privately owned United States-flag commercial vessels to ship at least 50 percent of the gross tonnage (computed separately for dry bulk carries, dry cargo liners, and tankers) involved, whenever shipping any equipment, material, or commodities pursuant to this contract, to the extent such vessels are available at fair and reasonable rates for United States-flag commercial vessels.

(2) To furnish within 20 days following the date of loading for shipments originating within the United State or within 30 working days following the date of loading for shipments originating outside the United States, a legible copy of a rated "on-board" commercial ocean bill-of-lading in English for each shipment of cargo described in paragraph (1) of this section to both the Contracting Officer (through the prime contractor in the case of subcontractor bills-of-lading) and to the Division of National Cargo, Office of Market Development, Maritime Administration, Washington, DC 20590.

(3) To insert the substance of the provisions of this clause in all subcontracts issued pursuant to this contract.

By my signature hereunder, as Contractor, I certify that I am aware of the above provisions and requirements of the Cargo Preference Act and understand that the County may require Contractor to provide proof of the Contractor's/subcontractor's compliance with the Cargo Preference Act acceptable to County, the California Department of Transportation and the U.S. Department of Transportation Federal Highway Administration ("FHWA"). At the County Engineer's direction, Contractor shall certify in writing to County that Contractor and/or its subcontractors has/have complied with the Cargo Preference Act.

NOT FOR BID

BOARD OF SUPERVISORS

►

Dawn Rowe, Chair, Board of Supervisors

Dated: _____
SIGNED AND CERTIFIED THAT A COPY OF THIS
DOCUMENT HAS BEEN DELIVERED TO THE
CHAIRMAN OF THE BOARD

Lynna Monell
Clerk of the Board of Supervisors
of the San Bernardino County

By _____
Deputy

(Print or type name of corporation, company, contractor, etc.)

By _____
(Authorized signature - sign in blue ink)

Name _____
(Print or type name of person signing contract)

Title _____
(Print or Type)

Dated: _____

Address _____

FOR COUNTY USE ONLY

Approved as to Legal Form
► _____
, County Counsel

Date _____

Reviewed for Contract Compliance
► _____

Date _____

Reviewed/Approved by Department
► _____

Date _____

NOT FOR BID

EXHIBIT A - PREVAILING WAGE REQUIREMENTS, REQUIRED CONTRACT PROVISIONS FEDERAL-AID CONSTRUCTION CONTRACTS, FEMALE AND MINORITY GOALS, AND FEDERAL TRAINEE PROGRAM

A. All or a portion of the Scope of Work in the Contract requires the payment of prevailing wages and compliance with the following requirements:

1. Determination of Prevailing Rates:

Pursuant to Labor Code sections 1770, et seq., the County has obtained from the Director of the Department of Industrial Relations (DIR) pursuant to the California Labor Code, the general prevailing rates of per diem wages and the prevailing rates for holiday and overtime work in the locality in which the Scope of Work is to be performed. Copies of said rates are on file with the County, will be made available for inspection during regular business hours, may be included elsewhere in the specifications for the Scope of Work, and are also available online at www.dir.ca.gov. The wage rate for any classification not listed, but which may be required to execute the Scope of Work, shall be commensurate and in accord with specified rates for similar or comparable classifications for those performing similar or comparable duties. In accordance with Labor Code section 1773.2, the Contractor shall post, at appropriate and conspicuous locations on the job site, a schedule showing all applicable prevailing wage rates and shall comply with the requirements of Labor Code sections 1773, et seq.

2. Payment of Prevailing Rates

Each worker of the Contractor, or any subcontractor, engaged in the Scope of Work, shall be paid not less than the general prevailing wage rate, regardless of any contractual relationship which may be alleged to exist between the Contractor or any subcontractor, and such worker.

3. Prevailing Rate Penalty

The Contractor shall, as a penalty, forfeit two hundred dollars (\$200.00) to the County for each calendar day or portion thereof, for each worker paid less than the prevailing rates as determined by the Director of the DIR for such work or craft in which such worker is employed by the Contractor or by any subcontractor in connection with the Scope of Work. Pursuant to California Labor Code section 1775, the difference between such prevailing wage rates and the amount paid to each worker for each calendar day, or portion thereof, for which each worker was paid less than the prevailing wage rate, shall be paid to each worker by the Contractor.

4. Ineligible Contractors:

Pursuant to the provisions of Labor Code section 1777.1, the Labor Commissioner publishes and distributes a list of contractors ineligible to perform work as a contractor or subcontractor on a public works project. This list of debarred contractors is available from the DIR website at <http://www.dir.ca.gov/Public-Works/PublicWorks.html>. Any contract entered into between a contractor and a debarred subcontractor is void as a matter of law. A debarred subcontractor may not receive any public money for performing work as a subcontractor on a public works contract, and any public money that may have been paid to a debarred subcontractor by a contractor on the project shall be returned to the County. The Contractor shall be responsible for the payment of wages to workers as a debarred subcontractor who has been allowed to work on the Scope of Work.

5. Payroll Records:

- a. Pursuant to California Labor Code section 1776, the Contractor and each subcontractor, shall keep accurate certified payroll records, showing the name, address, social security number, work classification, straight time and overtime hours worked each day and week, and the actual per diem wages paid to each journeyman, apprentice, worker or other employee employed by them in

connection with the Scope of Work. The payroll records enumerated herein shall be verified by a written declaration made under penalty of perjury that the information contained in the payroll record is true and correct and that the Contractor or subcontractor has complied with the requirements of the California Labor Code sections 1771, 1811, and 1815 for any Scope of Work performed by his or her employees. The payroll records shall be available for inspection at all reasonable hours at the principal office of the Contractor on the following basis:

- i. A certified copy of an employee's payroll record shall be made available for inspection or furnished to such employee or his/her authorized representative on request;
 - ii. A certified copy of all payroll records shall be made available for inspection or furnished upon request to the County, the Division of Labor Standards Enforcement of the DIR;
 - iii. A certified copy of payroll records shall be made available upon request to the public for inspection or copies thereof made; provided, however, that a request by the public shall be made through either the County or the Division of Labor Standards Enforcement. If the requested payroll records have not been previously provided to the County or the Division of Labor Standards Enforcement, the requesting party shall, prior to being provided the records, reimburse the cost of preparation by the Contractor, subcontractor and the entity through which the request was made; the public shall not be given access to such records at the principal office of the Contractor;
 - iv. The Contractor shall file a certified copy of the payroll records with the entity that requested such records within ten (10) days after receipt of a written request; and
 - v. Copies provided to the public by the County or the Division of Labor Standards Enforcement shall be marked or obliterated in such a manner as to prevent disclosure of an individual's name, address and social security number. The name and address of the Contractor or any subcontractor, performing a part of the Scope of Work shall not be marked or obliterated. The Contractor shall inform the County of the location of payroll records, including the street address, city and county and shall, within five (5) working days, provide a notice of a change of location and address.
- b. The Contractor shall have ten (10) days from receipt of the written notice specifying in what respects the Contractor must comply with the above requirements. In the event Contractor does not comply with the requirements of this section within the ten (10) day period, the Contractor shall, as a penalty to the County, forfeit one-hundred dollars (\$100.00) for each calendar day, or portion thereof, for each worker, until strict compliance is effectuated. Upon the request of the Division of Labor Standards Enforcement, such penalty shall be withheld from any portion of the payments then due or to become due to the Contractor.

6. Limits on Hours of Work:

Pursuant to California Labor Code section 1810, eight (8) hours of labor shall constitute a legal day's work. Pursuant to California Labor Code section 1811, the time of service of any worker employed at any time by the Contractor or by a subcontractor, upon the Scope of Work or upon any part of the Scope of Work, is limited and restricted to eight (8) hours during any one calendar day and forty (40) hours during any one calendar week, except as provided for under Labor Code section 1815. Notwithstanding the foregoing provisions, work performed by employees of Contractor or any subcontractor, in excess of eight (8) hours per day

and forty (40) hours during any one week, shall be permitted upon compensation for all hours worked in excess of eight (8) hours per day at not less than one and one-half (1½) times the basic rate of pay.

7. Penalty for Excess Hours:

The Contractor shall pay to the County a penalty of twenty-five dollars (\$25.00) for each worker employed on the Scope of Work by the Contractor or any subcontractor, for each calendar day during which such worker is required or permitted to work more than eight (8) hours in any calendar day and forty (40) hours in any one calendar week, in violation of the provisions of the California Labor Code, unless compensation to the worker so employed by the Contractor is not less than one and one-half (1½) times the basic rate of pay for all hours worked in excess of eight (8) hours per day.

8. Senate Bill 854 (Chapter 28, Statutes of 2014) and Senate Bill 96 (Chapter 28, Statutes of 2017) Requirements:

a. Contractor shall comply with Senate Bill 854 and Senate Bill 96. The requirements include, but are not limited to, the following:

- i. No contractor or subcontractor may be listed on a bid proposal (submitted on or after March 1, 2015) for a public works project unless registered with the DIR pursuant to Labor Code section 1725.5, with limited exceptions from this requirements for bid purposes only as allowed under Labor Code section 1771.1(a).
- ii. No contractor or subcontractor may be awarded a contract for public work or perform work on a public works project (awarded on or after April 1, 2015) unless registered with the DIR pursuant to Labor Code section 1725.5.
- iii. This project is subject to compliance monitoring and enforcement by the DIR.
- iv. As required by the DIR, Contractor is required to post job site notices, as prescribed by regulation, regarding compliance monitoring and enforcement by the DIR.
- v. Contractors and all subcontractors must submit certified payroll records online to the Labor Commissioner for all new public works projects issued on or after April 1, 2015, and for all public works projects, new or ongoing, on or after January 1, 2016.
 - 1) The certified payroll must be submitted at least monthly to the Labor Commissioner.
 - 2) The County reserves the right to require Contractor and all subcontractors to submit certified payroll records more frequently than monthly to the Labor Commissioner.
 - 3) The certified payroll records must be in a format prescribed by the Labor Commissioner.
- vi. Registration with the DIR and the submission of certified payroll records to the Labor Commissioner are not required if the public works project is \$25,000 or less when the project is for construction, alteration, demolition, installation or repair work, or if the public works project is \$15,000 or less when the project is for maintenance work.

b. Labor Code section 1725.5 states the following:

“A contractor shall be registered pursuant to this section to be qualified to bid on, be listed in a bid proposal, subject to the requirements of Section 4104 of the Public Contract Code, or engage in the performance of any public work contract

that is subject to the requirements of this chapter. For the purposes of this section, "contractor" includes a subcontractor as defined by Section 1722.1.

(a) To qualify for registration under this section, a contractor shall do all of the following:

(1) (A) Register with the Department of Industrial Relations in the manner prescribed by the department and pay an initial nonrefundable application fee of four hundred dollars (\$400) to qualify for registration under this section and an annual renewal fee on or before July 1 of each year thereafter. The annual renewal fee shall be in a uniform amount set by the Director of Industrial Relations, and the initial registration and renewal fees may be adjusted no more than annually by the director to support the costs specified in Section 1771.3.

(B) Beginning June 1, 2019, a contractor may register or renew according to this subdivision in annual increments up to three years from the date of registration. Contractors who wish to do so will be required to prepay the applicable nonrefundable application or renewal fees to qualify for the number of years for which they wish to preregister.

(2) Provide evidence, disclosures, or releases as are necessary to establish all of the following:

(A) Workers' compensation coverage that meets the requirements of Division 4 (commencing with Section 3200) and includes sufficient coverage for any worker whom the contractor employs to perform work that is subject to prevailing wage requirements other than a contractor who is separately registered under this section. Coverage may be evidenced by a current and valid certificate of workers' compensation insurance or certification of self-insurance required under Section 7125 of the Business and Professions Code.

(B) If applicable, the contractor is licensed in accordance with Chapter 9 (commencing with Section 7000) of the Business and Professions Code.

(C) The contractor does not have any delinquent liability to an employee or the state for any assessment of back wages or related damages, interest, fines, or penalties pursuant to any final judgment, order, or determination by a court or any federal, state, or local administrative agency, including a confirmed arbitration award. However, for purposes of this paragraph, the contractor shall not be disqualified for any judgment, order, or determination that is under appeal, provided that the contractor has secured the payment of any amount eventually found due through a bond or other appropriate means.

(D) The contractor is not currently debarred under Section 1777.1 or under any other federal or state law providing for the debarment of contractors from public works.

(E) The contractor has not bid on a public works contract, been listed in a bid proposal, or engaged in the performance of a contract for public works without being lawfully registered in accordance with this section, within the preceding 12 months or since the effective date of the requirements set forth in subdivision (e), whichever is earlier. If a contractor is found to be in violation of the requirements of this paragraph, the period of disqualification shall be waived if both of the following are true:

(i) The contractor has not previously been found to be in violation of the requirements of this paragraph within the preceding 12 months.

(ii) The contractor pays an additional nonrefundable penalty registration fee of two thousand dollars (\$2,000).

(b) Fees received pursuant to this section shall be deposited in the State Public Works Enforcement Fund established by Section 1771.3 and shall be used only for the purposes specified in that section.

(c) A contractor who fails to pay the renewal fee required under paragraph (1) of subdivision (a) on or before the expiration of any prior period of registration shall be prohibited from bidding on or engaging in the performance of any contract for public work until once again registered pursuant to this section. If the failure to pay the renewal fee was inadvertent, the contractor may renew its registration retroactively by paying an additional nonrefundable penalty renewal fee equal to the amount of the renewal fee within 90 days of the due date of the renewal fee.

(d) If, after a body awarding a contract accepts the contractor's bid or awards the contract, the work covered by the bid or contract is determined to be a public work to which Section 1771 applies, either as the result of a determination by the director pursuant to Section 1773.5 or a court decision, the requirements of this section shall not apply, subject to the following requirements:

(1) The body that awarded the contract failed, in the bid specification or in the contract documents, to identify as a public work that portion of the work that the determination or decision subsequently classifies as a public work.

(2) Within 20 days following service of notice on the awarding body of a determination by the Director of Industrial Relations pursuant to Section 1773.5 or a decision by a court that the contract was for public work as defined in this chapter, the contractor and any subcontractors are registered under this section or are replaced by a contractor or subcontractors who are registered under this section.

(3) The requirements of this section shall apply prospectively only to any subsequent bid, bid proposal, contract, or work performed after the awarding body is served with notice of the determination or decision referred to in paragraph (2).

(e) The requirements of this section shall apply to any bid proposal submitted on or after March 1, 2015, to any contract for public work, as defined in this chapter, executed on or after April 1, 2015, and to any work performed under a contract for public work on or after January 1, 2018, regardless of when the contract for public work was executed.

(f) This section does not apply to work performed on a public works project of twenty-five thousand dollars (\$25,000) or less when the project is for construction, alteration, demolition, installation, or repair work or to work performed on a public works project of fifteen thousand dollars (\$15,000) or less when the project is for maintenance work."

c. Labor Code section 1771.1 states the following:

"(a) A contractor or subcontractor shall not be qualified to bid on, be listed in a bid proposal, subject to the requirements of Section 4104 of the Public Contract Code, or engage in the performance of any contract for public work, as defined in this

chapter, unless currently registered and qualified to perform public work pursuant to Section 1725.5. It is not a violation of this section for an unregistered contractor to submit a bid that is authorized by Section 7029.1 of the Business and Professions Code or by Section 10164 or 20103.5 of the Public Contract Code, provided the contractor is registered to perform public work pursuant to Section 1725.5 at the time the contract is awarded.

(b) Notice of the requirement described in subdivision (a) shall be included in all bid invitations and public works contracts, and a bid shall not be accepted nor any contract or subcontract entered into without proof of the contractor or subcontractor's current registration to perform public work pursuant to Section 1725.5.

(c) An inadvertent error in listing a subcontractor who is not registered pursuant to Section 1725.5 in a bid proposal shall not be grounds for filing a bid protest or grounds for considering the bid nonresponsive, provided that any of the following apply:

(1) The subcontractor is registered prior to the bid opening.

(2) Within 24 hours after the bid opening, the subcontractor is registered and has paid the penalty registration fee specified in subparagraph (E) of paragraph (2) of subdivision (a) of Section 1725.5.

(3) The subcontractor is replaced by another registered subcontractor pursuant to Section 4107 of the Public Contract Code.

(d) Failure by a subcontractor to be registered to perform public work as required by subdivision (a) shall be grounds under Section 4107 of the Public Contract Code for the contractor, with the consent of the awarding authority, to substitute a subcontractor who is registered to perform public work pursuant to Section 1725.5 in place of the unregistered subcontractor.

(e) The department shall maintain on its Internet Web site a list of contractors who are currently registered to perform public work pursuant to Section 1725.5.

(f) A contract entered into with any contractor or subcontractor in violation of subdivision (a) shall be subject to cancellation, provided that a contract for public work shall not be unlawful, void, or voidable solely due to the failure of the awarding body, contractor, or any subcontractor to comply with the requirements of Section 1725.5 or this section.

(g) If the Labor Commissioner or his or her designee determines that a contractor or subcontractor engaged in the performance of any public work contract without having been registered in accordance with this section, the contractor or subcontractor shall forfeit, as a civil penalty to the state, one hundred dollars (\$100) for each day of work performed in violation of the registration requirement, not to exceed an aggregate penalty of eight thousand dollars (\$8,000) in addition to any penalty registration fee assessed pursuant to clause (ii) of subparagraph (E) of paragraph (2) of subdivision (a) of Section 1725.5.

(h)(1) In addition to, or in lieu of, any other penalty or sanction authorized pursuant to this chapter, a higher tiered public works contractor or subcontractor who is found to have entered into a subcontract with an unregistered lower tier subcontractor to perform any public work in violation of the requirements of Section 1725.5 or this section shall be subject to forfeiture, as a civil penalty to the state, of one hundred dollars (\$100) for each day the unregistered lower tier subcontractor

performs work in violation of the registration requirement, not to exceed an aggregate penalty of ten thousand dollars (\$10,000).

(2) The Labor Commissioner shall use the same standards specified in subparagraph (A) of paragraph (2) of subdivision (a) of Section 1775 when determining the severity of the violation and what penalty to assess, and may waive the penalty for a first time violation that was unintentional and did not hinder the Labor Commissioner's ability to monitor and enforce compliance with the requirements of this chapter.

(3) A higher tiered public works contractor or subcontractor shall not be liability for penalties assessed pursuant to paragraph (1) if the lower tier subcontractor's performance is in violation of the requirements of Section 1725.5 due to the revocation of a previously approved registration.

(4) A subcontractor shall not be liable for any penalties assessed against a higher tiered public works contractor or subcontractor pursuant to paragraph (1). A higher tiered public works contractor or subcontractor may not require a lower tiered subcontractor to indemnify or otherwise be liable for any penalties pursuant to paragraph (1).

(i) The Labor Commissioner or his or her designee shall issue a civil wage and penalty assessment, in accordance with the provisions of Section 1741, upon determination of penalties pursuant to subdivision (g) and subparagraph (B) of paragraph (1) of subdivision (h). Review of a civil wage and penalty assessment issued under this subdivision may be requested in accordance with the provisions of Section 1742. The regulations of the Director of Industrial Relations, which govern proceedings for review of civil wage and penalty assessments and the withholding of contract payments under Article 1 (commencing with Section 1720) and Article 2 (commencing with Section 1770), shall apply.

(j)(1) Where a contractor or subcontractor engages in the performance of any public work contract without having been registered in violation of the requirements of Section 1725.5 or this section, the Labor Commissioner shall issue and serve a stop order prohibiting the use of the unregistered contractor or the unregistered subcontractor on all public works until the unregistered contractor or unregistered subcontractor is registered. The stop order shall not apply to work by registered contractors or subcontractors on the public work.

(2) A stop order may be personally served upon the contractor or subcontractor by either of the following methods:

(A) Manual delivery of the order to the contractor or subcontractor personally.

(B) Leaving signed copies of the order with the person who is apparently in charge at the site of the public work and by thereafter mailing copies of the order by first class mail, postage prepaid to the contractor or subcontractor at the address on file with either of the following:

(i) The Contractors' State License Board.

(ii) The Secretary of State.

(3) The stop order shall be effective immediately upon service and shall be subject to appeal by the party contracting with the unregistered contractor or subcontractor, by the unregistered contractor or subcontractor, or both. The appeal, hearing, and any further review of the hearing decision shall be governed by the procedures, time limits, and other requirements specified in subdivision (a) of Section 238.1.

(k) Failure of a contractor or subcontractor, owner, director, officer, or managing agent of the contractor or subcontractor to observe a stop order issued and served upon him or her pursuant to subdivision (j) is guilty of a misdemeanor punishable by imprisonment in county jail not exceeding 60 days or by a fine not exceeding ten thousand dollars (\$10,000), or both.

(l) This section shall apply to any bid proposal submitted on or after March 1, 2015, and any contract for public work entered into on or after April 1, 2015. This section shall also apply to the performance of any public work, as defined in this chapter, on or after January 1, 2018, regardless of when the contract for public work was entered.

(m) Penalties received pursuant to this section shall be deposited in the State Public Works Enforcement Fund established by Section 1771.3 and shall be used only for the purposes specified in that section.

(n) This section shall not apply to work performed on a public works project of twenty-five thousand dollars (\$25,000) or less when the project is for construction, alteration, demolition, installation, or repair work or to work performed on a public works project of fifteen thousand dollars (\$15,000) or less when the project is for maintenance work.”

d. Labor Code section 1771.4 states the following:

“a) All of the following are applicable to all public works projects that are otherwise subject to the requirements of this chapter:

(1) The call for bids and contract documents shall specify that the project is subject to compliance monitoring and enforcement by the Department of Industrial Relations.

(2) The awarding body shall post or require the prime contractor to post job site notices, as prescribed by regulation.

(3) Each contractor and subcontractor shall furnish the records specified in Section 1776 directly to the Labor Commissioner, in the following manner:

(A) At least monthly or more frequently if specified in the contract with the awarding body.

(B) In a format prescribed by the Labor Commissioner.

(4) If the contractor or subcontractor is not registered pursuant to Section 1725.5 and is performing work on a project for which registration is not required because of subdivision (f) of Section 1725.5, the unregistered contractor or subcontractor is not required to furnish the records specified in Section 1776 directly to the Labor Commissioner but shall retain the records specified in Section 1776 for at least three years after completion of the work.

(5) The department shall undertake those activities it deems necessary to monitor and enforce compliance with prevailing wage requirements.

(b) The Labor Commissioner may exempt a public works project from compliance with all or part of the requirements of subdivision (a) if either of the following occurs:

(1) The awarding body has enforced an approved labor compliance program, as defined in Section 1771.5, on all public works projects under its authority, except

those deemed exempt pursuant to subdivision (a) of Section 1771.5, continuously since December 31, 2011.

(2) The awarding body has entered into a collective bargaining agreement that binds all contractors performing work on the project and that includes a mechanism for resolving disputes about the payment of wages.

(c) The requirements of paragraph (1) of subdivision (a) shall only apply to contracts for public works projects awarded on or after January 1, 2015.

(d) The requirements of paragraph (3) of subdivision (a) shall apply to all contracts for public work, whether new or ongoing, on or after January 1, 2016.”

B. STATE PUBLIC WORKS APPRENTICESHIP REQUIREMENTS

1. State Public Works Apprenticeship Requirements:

- a. The Contractor is responsible for compliance with Labor Code section 1777.5 and the California Code of Regulations, title 8, sections 230 – 230.2 for all apprenticeable occupations (denoted with “#” symbol next to craft name in DIR Prevailing Wage Determination), whether employed by the Contractor, subcontractor, vendor or consultant. Included in these requirements is (1) the Contractor’s requirement to provide notification (i.e. DAS-140) to the appropriate apprenticeship committees; (2) pay training fund contributions for each apprenticeable hour employed on the Contract; and (3) utilize apprentices in a minimum ratio of not less than one apprentice hour for each five journeyman hours by completion of Contract work (unless an exception is granted in accordance with Labor Code section 1777.5) or request for the dispatch of apprentices.
- b. Any apprentices employed to perform any of the Scope of Work shall be paid the standard wage to apprentices under the regulations of the craft or trade for which such apprentice is employed, and such individual shall be employed only for the work of the craft or trade to which such individual is registered. Only apprentices, as defined in California Labor Code section 3077, who are in training under apprenticeship standards and written apprenticeship agreements under California Labor Code sections 3070 et seq. are eligible to be employed for the Scope of Work. The employment and training of each apprentice shall be in accordance with the provisions of the apprenticeship standards and apprentice agreements under which such apprentice is training.

2. Compliance with [California Labor Code section 1777.5](#) requires all public works contractors to:

- a. Submit Contract Award Information (DAS-140):
 - i. Although there are a few exemptions (identified below), all Contractors, regardless of union affiliation, must submit contract award information when performing on a California public works project.
 - ii. The DAS-140 is a notification “announcement” of the Contractor’s participation on a public works project—*it is not a request for the dispatch of an apprentice.*
 - iii. Contractors shall submit the contract award information (you may use form DAS 140) within 10 days of the execution of the prime contract or subcontract, but in no event later than the first day in which the Contractor has workers employed on the public work.
 - iv. Contractors who are already approved to train apprentices (i.e. check “Box 1” on the DAS-140) shall only be required to submit the form to their approved program.
 - v. Contractors who are NOT approved to train apprentices (i.e. those that check either “Box 2” or “Box 3” on the DAS-140) shall submit the DAS-140

TO EACH of the apprenticeship program sponsors in the area of your public works project. For a listing of apprenticeship programs see <http://www.dir.ca.gov/Databases/das/pwaddrstart.asp>.

b. Employ Registered Apprentices

- i. Labor Code section 1777.5 requires that a contractor performing work in an “apprenticeable” craft must employ one (1) hour of apprentice work for every five (5) hours performed by a journeyman. This ratio shall be met prior to the Contractor’s completion of work on the project. “Apprenticeable” crafts are denoted with a pound symbol “#” in front of the craft name on the prevailing wage determination.
- ii. All Contractors who do not fall within an exemption category (see below) must request for dispatch of an apprentice from an apprenticeship program (for each apprenticeable craft or trade) by giving the program actual notice of at least 72 hours (business days only) before the date on which apprentices are required.
- iii. Contractors may use the “DAS-142” form for making a request for the dispatch of an apprentice.
- iv. Contractors who are participating in an approved apprenticeship training program and who did not receive sufficient number of apprentices from their initial request must request dispatch of apprentices from ALL OTHER apprenticeship committees in the project area in order to fulfill this requirement.
- v. Contractor should maintain and submit proof (when requested) of its DAS-142 submittal to the apprenticeship committees (e.g. fax transmittal confirmation). A Contractor has met its requirement to employ apprentices only after it has successfully made a dispatch request to all apprenticeship programs in the project area.
- vi. Only “registered” apprentices may be paid the prevailing apprentice rates and must, at all times work under the supervision of a Journeyman (Cal. Code Regs., tit 8, § 230.1).

c. Make Training Fund Contributions

- i. Contractors performing in apprenticeable crafts on public works projects, must make training fund contributions in the amount established in the prevailing wage rate publication for journeymen and apprentices.
- ii. Contractors may use the “CAC-2” form for submittal of their training fund contributions.
- iii. Contractors who do not submit their training fund contributions to an approved apprenticeship training program must submit their contributions to the California Apprenticeship Council (CAC), PO Box 420603, San Francisco, CA 94142-0603.
- iv. Training fund contributions to the CAC are due and payable on the 15th day of the month for work performed during the preceding month.
- v. The “training” contribution amount identified on the prevailing wage determination shall not be paid to the worker, unless the worker falls within one of the exemption categories listed below.

3. Exemptions to Apprenticeship Requirements:

- a. The following are exempt from having to comply with California apprenticeship requirements. These types of contractors do not need to submit a DAS-140, DAS-142, make training fund contributions, or utilize apprentices:
 - i. When the Contractor holds a sole proprietor license (“Owner-Operator”) and no workers were employed by the Contractor. In other words, the contractor performed the entire work from start to finish and worked alone.
 - ii. Contractors performing in non-apprenticeable crafts. “Apprenticeable” crafts are denoted with a pound symbol “#” in front of the craft name on the prevailing wage determination.
 - iii. When the Contractor has a direct contract with the Public Agency that is under \$30,000.
 - iv. When the project is 100% federally-funded and the funding of the project does not contain any city, county, and/or state monies (unless the project is administered by a state agency in which case the apprenticeship requirements apply).
 - v. When the project is a private project not covered by the definition of public works as found in Labor Code section 1720.

4. Exemption from Apprenticeship Ratios:

- a. The Joint Apprenticeship Committee shall have the discretion to grant a certificate, which shall be subject to the approval of the Administrator of Apprenticeship, exempting the Contractor from the 1-to-5 ratio set forth in this Section when it finds that any one of the following conditions are met:
 - i. Unemployment for the previous three-month period in such area exceeds an average of fifteen percent (15%); or
 - ii. The number of apprentices in training in such area exceeds a ratio of 1-to-5 in relation to journeymen; or
 - iii. The Apprenticeable Craft or Trade is replacing at least one-thirtieth (1/30) of its journeymen annually through apprenticeship training, either on a statewide basis or on a local basis; or
 - iv. If assignment of an apprentice to any work performed under the Contract Documents would create a condition which would jeopardize such apprentice's life or the life, safety or property of fellow employees or the public at large, or if the specific task to which the apprentice is to be assigned is of such a nature that training cannot be provided by a journeyman.
- b. When such exemptions from the 1-to-5 ratio between apprentices and journeymen are granted to an organization which represents contractors in a specific trade on a local or statewide basis, the member contractors will not be required to submit individual applications for approval to local Joint Apprenticeship Committees, provided they are already covered by the local apprenticeship standards.

5. Contractor's Compliance:

- a. The responsibility of compliance with this Section for all Apprenticeable Trades or Crafts is solely and exclusively that of the Contractor. All decisions of the Joint Apprenticeship Committee(s) under this Section are subject to the provisions of California Labor Code section 3081 and penalties are pursuant to Labor Code section 1777.7 and the determination of the Labor Commissioner.

**REQUIRED CONTRACT PROVISIONS
FEDERAL-AID CONSTRUCTION CONTRACTS**

- I. General
- II. Nondiscrimination
- III. Nonsegregated Facilities
- IV. Davis-Bacon and Related Act Provisions
- V. Contract Work Hours and Safety Standards Act Provisions
- VI. Subletting or Assigning the Contract
- VII. Safety: Accident Prevention
- VIII. False Statements Concerning Highway Projects
- IX. Implementation of Clean Air Act and Federal Water Pollution Control Act
- X. Compliance with Governmentwide Suspension and Debarment Requirements
- XI. Certification Regarding Use of Contract Funds for Lobbying

3. A breach of any of the stipulations contained in these Required Contract Provisions may be sufficient grounds for withholding of progress payments, withholding of final payment, termination of the contract, suspension / debarment or any other action determined to be appropriate by the contracting agency and FHWA.

4. Selection of Labor: During the performance of this contract, the contractor shall not use convict labor for any purpose within the limits of a construction project on a Federal-aid highway unless it is labor performed by convicts who are on parole, supervised release, or probation. The term Federal-aid highway does not include roadways functionally classified as local roads or rural minor collectors.

ATTACHMENTS

A. Employment and Materials Preference for Appalachian Development Highway System or Appalachian Local Access Road Contracts (included in Appalachian contracts only)

I. GENERAL

1. Form FHWA-1273 must be physically incorporated in each construction contract funded under Title 23 (excluding emergency contracts solely intended for debris removal). The contractor (or subcontractor) must insert this form in each subcontract and further require its inclusion in all lower tier subcontracts (excluding purchase orders, rental agreements and other agreements for supplies or services).

The applicable requirements of Form FHWA-1273 are incorporated by reference for work done under any purchase order, rental agreement or agreement for other services. The prime contractor shall be responsible for compliance by any subcontractor, lower-tier subcontractor or service provider.

Form FHWA-1273 must be included in all Federal-aid design-build contracts, in all subcontracts and in lower tier subcontracts (excluding subcontracts for design services, purchase orders, rental agreements and other agreements for supplies or services). The design-builder shall be responsible for compliance by any subcontractor, lower-tier subcontractor or service provider.

Contracting agencies may reference Form FHWA-1273 in bid proposal or request for proposal documents, however, the Form FHWA-1273 must be physically incorporated (not referenced) in all contracts, subcontracts and lower-tier subcontracts (excluding purchase orders, rental agreements and other agreements for supplies or services related to a construction contract).

2. Subject to the applicability criteria noted in the following sections, these contract provisions shall apply to all work performed on the contract by the contractor's own organization and with the assistance of workers under the contractor's immediate superintendence and to all work performed on the contract by piecework, station work, or by subcontract.

II. NONDISCRIMINATION

The provisions of this section related to 23 CFR Part 230 are applicable to all Federal-aid construction contracts and to all related construction subcontracts of \$10,000 or more. The provisions of 23 CFR Part 230 are not applicable to material supply, engineering, or architectural service contracts.

In addition, the contractor and all subcontractors must comply with the following policies: Executive Order 11246, 41 CFR 60, 29 CFR 1625-1627, Title 23 USC Section 140, the Rehabilitation Act of 1973, as amended (29 USC 794), Title VI of the Civil Rights Act of 1964, as amended, and related regulations including 49 CFR Parts 21, 26 and 27; and 23 CFR Parts 200, 230, and 633.

The contractor and all subcontractors must comply with: the requirements of the Equal Opportunity Clause in 41 CFR 60- 1.4(b) and, for all construction contracts exceeding \$10,000, the Standard Federal Equal Employment Opportunity Construction Contract Specifications in 41 CFR 60-4.3.

Note: The U.S. Department of Labor has exclusive authority to determine compliance with Executive Order 11246 and the policies of the Secretary of Labor including 41 CFR 60, and 29 CFR 1625-1627. The contracting agency and the FHWA have the authority and the responsibility to ensure compliance with Title 23 USC Section 140, the Rehabilitation Act of 1973, as amended (29 USC 794), and Title VI of the Civil Rights Act of 1964, as amended, and related regulations including 49 CFR Parts 21, 26 and 27; and 23 CFR Parts 200, 230, and 633.

The following provision is adopted from 23 CFR 230, Appendix A, with appropriate revisions to conform to the U.S. Department of Labor (US DOL) and FHWA requirements.

1. **Equal Employment Opportunity:** Equal employment opportunity (EEO) requirements not to discriminate and to take affirmative action to assure equal opportunity as set forth under laws, executive orders, rules, regulations (28 CFR 35, 29 CFR 1630, 29 CFR 1625-1627, 41 CFR 60 and 49 CFR 27) and orders of the Secretary of Labor as modified by the provisions prescribed herein, and imposed pursuant to 23 U.S.C. 140 shall constitute the EEO and specific affirmative action standards for the contractor's project activities under

this contract. The provisions of the Americans with Disabilities Act of 1990 (42 U.S.C. 12101 et seq.) set forth under 28 CFR 35 and 29 CFR 1630 are incorporated by reference in this contract. In the execution of this contract, the contractor agrees to comply with the following minimum specific requirement activities of EEO:

a. The contractor will work with the contracting agency and the Federal Government to ensure that it has made every good faith effort to provide equal opportunity with respect to all of its terms and conditions of employment and in their review of activities under the contract.

b. The contractor will accept as its operating policy the following statement:

"It is the policy of this Company to assure that applicants are employed, and that employees are treated during employment, without regard to their race, religion, sex, color, national origin, age or disability. Such action shall include: employment, upgrading, demotion, or transfer; recruitment or recruitment advertising; layoff or termination; rates of pay or other forms of compensation; and selection for training, including apprenticeship, pre-apprenticeship, and/or on-the-job training."

2. **EEO Officer:** The contractor will designate and make known to the contracting officers an EEO Officer who will have the responsibility for and must be capable of effectively administering and promoting an active EEO program and who must be assigned adequate authority and responsibility to do so.

3. **Dissemination of Policy:** All members of the contractor's staff who are authorized to hire, supervise, promote, and discharge employees, or who recommend such action, or who are substantially involved in such action, will be made fully cognizant of, and will implement, the contractor's EEO policy and contractual responsibilities to provide EEO in each grade and classification of employment. To ensure that the above agreement will be met, the following actions will be taken as a minimum:

a. Periodic meetings of supervisory and personnel office employees will be conducted before the start of work and then not less often than once every six months, at which time the contractor's EEO policy and its implementation will be reviewed and explained. The meetings will be conducted by the EEO Officer.

b. All new supervisory or personnel office employees will be given a thorough indoctrination by the EEO Officer, covering all major aspects of the contractor's EEO obligations within thirty days following their reporting for duty with the contractor.

c. All personnel who are engaged in direct recruitment for the project will be instructed by the EEO Officer in the contractor's procedures for locating and hiring minorities and women.

d. Notices and posters setting forth the contractor's EEO policy will be placed in areas readily accessible to employees, applicants for employment and potential employees.

e. The contractor's EEO policy and the procedures to implement such policy will be brought to the attention of employees by means of meetings, employee handbooks, or other appropriate means.

4. **Recruitment:** When advertising for employees, the contractor will include in all advertisements for employees the notation: "An Equal Opportunity Employer." All such advertisements will be placed in publications having a large circulation among minorities and women in the area from which the project work force would normally be derived.

a. The contractor will, unless precluded by a valid bargaining agreement, conduct systematic and direct recruitment through public and private employee referral sources likely to yield qualified minorities and women. To meet this requirement, the contractor will identify sources of potential minority group employees, and establish with such identified sources procedures whereby minority and women applicants may be referred to the contractor for employment consideration.

b. In the event the contractor has a valid bargaining agreement providing for exclusive hiring hall referrals, the contractor is expected to observe the provisions of that agreement to the extent that the system meets the contractor's compliance with EEO contract provisions. Where implementation of such an agreement has the effect of discriminating against minorities or women, or obligates the contractor to do the same, such implementation violates Federal nondiscrimination provisions.

c. The contractor will encourage its present employees to refer minorities and women as applicants for employment. Information and procedures with regard to referring such applicants will be discussed with employees.

5. **Personnel Actions:** Wages, working conditions, and employee benefits shall be established and administered, and personnel actions of every type, including hiring, upgrading, promotion, transfer, demotion, layoff, and termination, shall be taken without regard to race, color, religion, sex, national origin, age or disability. The following procedures shall be followed:

a. The contractor will conduct periodic inspections of project sites to insure that working conditions and employee facilities do not indicate discriminatory treatment of project site personnel.

b. The contractor will periodically evaluate the spread of wages paid within each classification to determine any evidence of discriminatory wage practices.

c. The contractor will periodically review selected personnel actions in depth to determine whether there is evidence of discrimination. Where evidence is found, the contractor will promptly take corrective action. If the review indicates that the discrimination may extend beyond the actions reviewed, such corrective action shall include all affected persons.

d. The contractor will promptly investigate all complaints of alleged discrimination made to the contractor in connection with its obligations under this contract, will attempt to resolve such complaints, and will take appropriate corrective action within a reasonable time. If the investigation indicates that the discrimination may affect persons other than the complainant, such corrective action shall include such other persons. Upon completion of each investigation, the contractor will inform every complainant of all of their avenues of appeal.

6. **Training and Promotion:**

a. The contractor will assist in locating, qualifying, and increasing the skills of minorities and women who are

applicants for employment or current employees. Such efforts should be aimed at developing full journey level status employees in the type of trade or job classification involved.

b. Consistent with the contractor's work force requirements and as permissible under Federal and State regulations, the contractor shall make full use of training programs, i.e., apprenticeship, and on-the-job training programs for the geographical area of contract performance. In the event a special provision for training is provided under this contract, this subparagraph will be superseded as indicated in the special provision. The contracting agency may reserve training positions for persons who receive welfare assistance in accordance with 23 U.S.C. 140(a).

c. The contractor will advise employees and applicants for employment of available training programs and entrance requirements for each.

d. The contractor will periodically review the training and promotion potential of employees who are minorities and women and will encourage eligible employees to apply for such training and promotion.

7. **Unions:** If the contractor relies in whole or in part upon unions as a source of employees, the contractor will use good faith efforts to obtain the cooperation of such unions to increase opportunities for minorities and women. Actions by the contractor, either directly or through a contractor's association acting as agent, will include the procedures set forth below:

a. The contractor will use good faith efforts to develop, in cooperation with the unions, joint training programs aimed toward qualifying more minorities and women for membership in the unions and increasing the skills of minorities and women so that they may qualify for higher paying employment.

b. The contractor will use good faith efforts to incorporate an EEO clause into each union agreement to the end that such union will be contractually bound to refer applicants without regard to their race, color, religion, sex, national origin, age or disability.

c. The contractor is to obtain information as to the referral practices and policies of the labor union except that to the extent such information is within the exclusive possession of the labor union and such labor union refuses to furnish such information to the contractor, the contractor shall so certify to the contracting agency and shall set forth what efforts have been made to obtain such information.

d. In the event the union is unable to provide the contractor with a reasonable flow of referrals within the time limit set forth in the collective bargaining agreement, the contractor will, through independent recruitment efforts, fill the employment vacancies without regard to race, color, religion, sex, national origin, age or disability; making full efforts to obtain qualified and/or qualifiable minorities and women. The failure of a union to provide sufficient referrals (even though it is obligated to provide exclusive referrals under the terms of a collective bargaining agreement) does not relieve the contractor from the requirements of this paragraph. In the event the union referral practice prevents the contractor from meeting the obligations pursuant to Executive Order 11246, as amended, and these special provisions, such contractor shall immediately notify the contracting agency.

8. **Reasonable Accommodation for Applicants / Employees with Disabilities:** The contractor must be familiar

with the requirements for and comply with the Americans with Disabilities Act and all rules and regulations established there under. Employers must provide reasonable accommodation in all employment activities unless to do so would cause an undue hardship.

9. **Selection of Subcontractors, Procurement of Materials and Leasing of Equipment:** The contractor shall not discriminate on the grounds of race, color, religion, sex, national origin, age or disability in the selection and retention of subcontractors, including procurement of materials and leases of equipment. The contractor shall take all necessary and reasonable steps to ensure nondiscrimination in the administration of this contract.

a. The contractor shall notify all potential subcontractors and suppliers and lessors of their EEO obligations under this contract.

b. The contractor will use good faith efforts to ensure subcontractor compliance with their EEO obligations.

10. **Assurance Required by 49 CFR 26.13(b):**

a. The requirements of 49 CFR Part 26 and the State DOT's U.S. DOT-approved DBE program are incorporated by reference.

b. The contractor or subcontractor shall not discriminate on the basis of race, color, national origin, or sex in the performance of this contract. The contractor shall carry out applicable requirements of 49 CFR Part 26 in the award and administration of DOT-assisted contracts. Failure by the contractor to carry out these requirements is a material breach of this contract, which may result in the termination of this contract or such other remedy as the contracting agency deems appropriate.

11. **Records and Reports:** The contractor shall keep such records as necessary to document compliance with the EEO requirements. Such records shall be retained for a period of three years following the date of the final payment to the contractor for all contract work and shall be available at reasonable times and places for inspection by authorized representatives of the contracting agency and the FHWA.

a. The records kept by the contractor shall document the following:

(1) The number and work hours of minority and non-minority group members and women employed in each work classification on the project;

(2) The progress and efforts being made in cooperation with unions, when applicable, to increase employment opportunities for minorities and women; and

(3) The progress and efforts being made in locating, hiring, training, qualifying, and upgrading minorities and women;

b. The contractors and subcontractors will submit an annual report to the contracting agency each July for the duration of the project, indicating the number of minority, women, and non-minority group employees currently engaged in each work classification required by the contract work. This information is to be reported on [Form FHWA-1391](#). The staffing data should represent the project work force on board in all or any part of the last payroll period preceding the end of July. If on-the-job training is being required by special provision, the contractor

will be required to collect and report training data. The employment data should reflect the work force on board during all or any part of the last payroll period preceding the end of July.

III. NONSEGREGATED FACILITIES

This provision is applicable to all Federal-aid construction contracts and to all related construction subcontracts of \$10,000 or more.

The contractor must ensure that facilities provided for employees are provided in such a manner that segregation on the basis of race, color, religion, sex, or national origin cannot result. The contractor may neither require such segregated use by written or oral policies nor tolerate such use by employee custom. The contractor's obligation extends further to ensure that its employees are not assigned to perform their services at any location, under the contractor's control, where the facilities are segregated. The term "facilities" includes waiting rooms, work areas, restaurants and other eating areas, time clocks, restrooms, washrooms, locker rooms, and other storage or dressing areas, parking lots, drinking fountains, recreation or entertainment areas, transportation, and housing provided for employees. The contractor shall provide separate or single-user restrooms and necessary dressing or sleeping areas to assure privacy between sexes.

IV. DAVIS-BACON AND RELATED ACT PROVISIONS

This section is applicable to all Federal-aid construction projects exceeding \$2,000 and to all related subcontracts and lower-tier subcontracts (regardless of subcontract size). The requirements apply to all projects located within the right-of-way of a roadway that is functionally classified as Federal-aid highway. This excludes roadways functionally classified as local roads or rural minor collectors, which are exempt. Contracting agencies may elect to apply these requirements to other projects.

The following provisions are from the U.S. Department of Labor regulations in 29 CFR 5.5 "Contract provisions and related matters" with minor revisions to conform to the FHWA- 1273 format and FHWA program requirements.

1. Minimum wages

a. All laborers and mechanics employed or working upon the site of the work, will be paid unconditionally and not less often than once a week, and without subsequent deduction or rebate on any account (except such payroll deductions as are permitted by regulations issued by the Secretary of Labor under the Copeland Act (29 CFR part 3)), the full amount of wages and bona fide fringe benefits (or cash equivalents thereof) due at time of payment computed at rates not less than those contained in the wage determination of the Secretary of Labor which is attached hereto and made a part hereof, regardless of any contractual relationship which may be alleged to exist between the contractor and such laborers and mechanics.

Contributions made or costs reasonably anticipated for bona fide fringe benefits under section 1(b)(2) of the Davis-Bacon Act on behalf of laborers or mechanics are considered wages paid to such laborers or mechanics, subject to the provisions

of paragraph 1.d. of this section; also, regular contributions made or costs incurred for more than a weekly period (but not less often than quarterly) under plans, funds, or programs which cover the particular weekly period, are deemed to be constructively made or incurred during such weekly period. Such laborers and mechanics shall be paid the appropriate wage rate and fringe benefits on the wage determination for the classification of work actually performed, without regard to skill, except as provided in 29 CFR 5.5(a)(4). Laborers or mechanics performing work in more than one classification may be compensated at the rate specified for each classification for the time actually worked therein: Provided, That the employer's payroll records accurately set forth the time spent in each classification in which work is performed. The wage determination (including any additional classification) and wage rates conformed under paragraph 1.b. of this section) and the Davis-Bacon poster (WH-1321) shall be posted at all times by the contractor and its subcontractors at the site of the work in a prominent and accessible place where it can be easily seen by the workers.

b.(1) The contracting officer shall require that any class of laborers or mechanics, including helpers, which is not listed in the wage determination and which is to be employed under the contract shall be classified in conformance with the wage determination. The contracting officer shall approve an additional classification and wage rate and fringe benefits therefore only when the following criteria have been met:

(i) The work to be performed by the classification requested is not performed by a classification in the wage determination; and

(ii) The classification is utilized in the area by the construction industry; and

(iii) The proposed wage rate, including any bona fide fringe benefits, bears a reasonable relationship to the wage rates contained in the wage determination.

(2) If the contractor and the laborers and mechanics to be employed in the classification (if known), or their representatives, and the contracting officer agree on the classification and wage rate (including the amount designated for fringe benefits where appropriate), a report of the action taken shall be sent by the contracting officer to the Administrator of the Wage and Hour Division, Employment Standards Administration, U.S. Department of Labor, Washington, DC 20210. The Administrator, or an authorized representative, will approve, modify, or disapprove every additional classification action within 30 days of receipt and so advise the contracting officer or will notify the contracting officer within the 30-day period that additional time is necessary.

(3) In the event the contractor, the laborers or mechanics to be employed in the classification or their representatives, and the contracting officer do not agree on the proposed classification and wage rate (including the amount designated for fringe benefits, where appropriate), the contracting officer shall refer the questions, including the views of all interested parties and the recommendation of the contracting officer, to the Wage and Hour Administrator for determination. The Wage and Hour Administrator, or an authorized representative, will issue a determination within 30 days of receipt and so advise the contracting officer or

will notify the contracting officer within the 30-day period that additional time is necessary.

(4) The wage rate (including fringe benefits where appropriate) determined pursuant to paragraphs 1.b.(2) or 1.b.(3) of this section, shall be paid to all workers performing work in the classification under this contract from the first day on which work is performed in the classification.

c. Whenever the minimum wage rate prescribed in the contract for a class of laborers or mechanics includes a fringe benefit which is not expressed as an hourly rate, the contractor shall either pay the benefit as stated in the wage determination or shall pay another bona fide fringe benefit or an hourly cash equivalent thereof.

d. If the contractor does not make payments to a trustee or other third person, the contractor may consider as part of the wages of any laborer or mechanic the amount of any costs reasonably anticipated in providing bona fide fringe benefits under a plan or program. Provided, That the Secretary of Labor has found, upon the written request of the contractor, that the applicable standards of the Davis-Bacon Act have been met. The Secretary of Labor may require the contractor to set aside in a separate account assets for the meeting of obligations under the plan or program.

2. Withholding

The contracting agency shall upon its own action or upon written request of an authorized representative of the Department of Labor, withhold or cause to be withheld from the contractor under this contract, or any other Federal contract with the same prime contractor, or any other federally- assisted contract subject to Davis-Bacon prevailing wage requirements, which is held by the same prime contractor, so much of the accrued payments or advances as may be considered necessary to pay laborers and mechanics, including apprentices, trainees, and helpers, employed by the contractor or any subcontractor the full amount of wages required by the contract. In the event of failure to pay any laborer or mechanic, including any apprentice, trainee, or helper, employed or working on the site of the work, all or part of the wages required by the contract, the contracting agency may, after written notice to the contractor, take such action as may be necessary to cause the suspension of any further payment, advance, or guarantee of funds until such violations have ceased.

3. Payrolls and basic records

a. Payrolls and basic records relating thereto shall be maintained by the contractor during the course of the work and preserved for a period of three years thereafter for all laborers and mechanics working at the site of the work. Such records shall contain the name, address, and social security number of each such worker, his or her correct classification, hourly rates of wages paid (including rates of contributions or costs anticipated for bona fide fringe benefits or cash equivalents thereof of the types described in section 1(b)(2)(B) of the Davis-Bacon Act), daily and weekly number of hours worked, deductions made and actual wages paid. Whenever the Secretary of Labor has found under 29 CFR 5.5(a)(1)(iv) that the wages of any laborer or mechanic include the amount of any costs reasonably anticipated in providing benefits under a plan or program described in section 1(b)(2)(B) of the Davis-

Bacon Act, the contractor shall maintain records which show that the commitment to provide such benefits is enforceable, that the plan or program is financially responsible, and that the plan or program has been communicated in writing to the laborers or mechanics affected, and records which show the costs anticipated or the actual cost incurred in providing such benefits. Contractors employing apprentices or trainees under approved programs shall maintain written evidence of the registration of apprenticeship programs and certification of trainee programs, the registration of the apprentices and trainees, and the ratios and wage rates prescribed in the applicable programs.

b.(1) The contractor shall submit weekly for each week in which any contract work is performed a copy of all payrolls to the contracting agency. The payrolls submitted shall set out accurately and completely all of the information required to be maintained under 29 CFR 5.5(a)(3)(i), except that full social security numbers and home addresses shall not be included on weekly transmittals. Instead the payrolls shall only need to include an individually identifying number for each employee (e.g. , the last four digits of the employee's social security number). The required weekly payroll information may be submitted in any form desired. Optional Form WH-347 is available for this purpose from the Wage and Hour Division Web site at <http://www.dol.gov/esa/whd/forms/wh347instr.htm> or its successor site. The prime contractor is responsible for the submission of copies of payrolls by all subcontractors. Contractors and subcontractors shall maintain the full social security number and current address of each covered worker, and shall provide them upon request to the contracting agency for transmission to the State DOT, the FHWA or the Wage and Hour Division of the Department of Labor for purposes of an investigation or audit of compliance with prevailing wage requirements. It is not a violation of this section for a prime contractor to require a subcontractor to provide addresses and social security numbers to the prime contractor for its own records, without weekly submission to the contracting agency..

(2) Each payroll submitted shall be accompanied by a "Statement of Compliance," signed by the contractor or subcontractor or his or her agent who pays or supervises the payment of the persons employed under the contract and shall certify the following:

(i) That the payroll for the payroll period contains the information required to be provided under §5.5 (a)(3)(ii) of Regulations, 29 CFR part 5, the appropriate information is being maintained under §5.5 (a)(3)(i) of Regulations, 29 CFR part 5, and that such information is correct and complete;

(ii) That each laborer or mechanic (including each helper, apprentice, and trainee) employed on the contract during the payroll period has been paid the full weekly wages earned, without rebate, either directly or indirectly, and that no deductions have been made either directly or indirectly from the full wages earned, other than permissible deductions as set forth in Regulations, 29 CFR part 3;

(iii) That each laborer or mechanic has been paid not less than the applicable wage rates and fringe benefits or cash equivalents for the classification of work performed, as specified in the applicable wage determination incorporated into the contract.

(3) The weekly submission of a properly executed certification set forth on the reverse side of Optional Form WH-347 shall satisfy the requirement for submission of the "Statement of Compliance" required by paragraph 3.b.(2) of this section.

(4) The falsification of any of the above certifications may subject the contractor or subcontractor to civil or criminal prosecution under section 1001 of title 18 and section 231 of title 31 of the United States Code.

c. The contractor or subcontractor shall make the records required under paragraph 3.a. of this section available for inspection, copying, or transcription by authorized representatives of the contracting agency, the State DOT, the FHWA, or the Department of Labor, and shall permit such representatives to interview employees during working hours on the job. If the contractor or subcontractor fails to submit the required records or to make them available, the FHWA may, after written notice to the contractor, the contracting agency or the State DOT, take such action as may be necessary to cause the suspension of any further payment, advance, or guarantee of funds. Furthermore, failure to submit the required records upon request or to make such records available may be grounds for debarment action pursuant to 29 CFR 5.12.

4. Apprentices and trainees

a. Apprentices (programs of the USDOL).

Apprentices will be permitted to work at less than the predetermined rate for the work they performed when they are employed pursuant to and individually registered in a bona fide apprenticeship program registered with the U.S. Department of Labor, Employment and Training Administration, Office of Apprenticeship Training, Employer and Labor Services, or with a State Apprenticeship Agency recognized by the Office, or if a person is employed in his or her first 90 days of probationary employment as an apprentice in such an apprenticeship program, who is not individually registered in the program, but who has been certified by the Office of Apprenticeship Training, Employer and Labor Services or a State Apprenticeship Agency (where appropriate) to be eligible for probationary employment as an apprentice.

The allowable ratio of apprentices to journeymen on the job site in any craft classification shall not be greater than the ratio permitted to the contractor as to the entire work force under the registered program. Any worker listed on a payroll at an apprentice wage rate, who is not registered or otherwise employed as stated above, shall be paid not less than the applicable wage rate on the wage determination for the classification of work actually performed. In addition, any apprentice performing work on the job site in excess of the ratio permitted under the registered program shall be paid not less than the applicable wage rate on the wage determination for the work actually performed. Where a contractor is performing construction on a project in a locality other than that in which its program is registered, the ratios and wage rates (expressed in percentages of the journeyman's hourly rate) specified in the contractor's or subcontractor's registered program shall be observed.

Every apprentice must be paid at not less than the rate specified in the registered program for the apprentice's level of progress, expressed as a percentage of the journeymen hourly

rate specified in the applicable wage determination. Apprentices shall be paid fringe benefits in accordance with the provisions of the apprenticeship program. If the apprenticeship program does not specify fringe benefits, apprentices must be paid the full amount of fringe benefits listed on the wage determination for the applicable classification. If the Administrator determines that a different practice prevails for the applicable apprentice classification, fringes shall be paid in accordance with that determination.

In the event the Office of Apprenticeship Training, Employer and Labor Services, or a State Apprenticeship Agency recognized by the Office, withdraws approval of an apprenticeship program, the contractor will no longer be permitted to utilize apprentices at less than the applicable predetermined rate for the work performed until an acceptable program is approved.

b. Trainees (programs of the USDOL).

Except as provided in 29 CFR 5.16, trainees will not be permitted to work at less than the predetermined rate for the work performed unless they are employed pursuant to and individually registered in a program which has received prior approval, evidenced by formal certification by the U.S. Department of Labor, Employment and Training Administration.

The ratio of trainees to journeymen on the job site shall not be greater than permitted under the plan approved by the Employment and Training Administration.

Every trainee must be paid at not less than the rate specified in the approved program for the trainee's level of progress, expressed as a percentage of the journeyman hourly rate specified in the applicable wage determination. Trainees shall be paid fringe benefits in accordance with the provisions of the trainee program. If the trainee program does not mention fringe benefits, trainees shall be paid the full amount of fringe benefits listed on the wage determination unless the Administrator of the Wage and Hour Division determines that there is an apprenticeship program associated with the corresponding journeyman wage rate on the wage determination which provides for less than full fringe benefits for apprentices. Any employee listed on the payroll at a trainee rate who is not registered and participating in a training plan approved by the Employment and Training Administration shall be paid not less than the applicable wage rate on the wage determination for the classification of work actually performed. In addition, any trainee performing work on the job site in excess of the ratio permitted under the registered program shall be paid not less than the applicable wage rate on the wage determination for the work actually performed.

In the event the Employment and Training Administration withdraws approval of a training program, the contractor will no longer be permitted to utilize trainees at less than the applicable predetermined rate for the work performed until an acceptable program is approved.

c. Equal employment opportunity. The utilization of apprentices, trainees and journeymen under this part shall be in conformity with the equal employment opportunity requirements of Executive Order 11246, as amended, and 29 CFR part 30.

d. Apprentices and Trainees (programs of the U.S. DOT).

Apprentices and trainees working under apprenticeship and skill training programs which have been certified by the Secretary of Transportation as promoting EEO in connection with Federal-aid highway construction programs are not subject to the requirements of paragraph 4 of this Section IV. The straight time hourly wage rates for apprentices and trainees under such programs will be established by the particular programs. The ratio of apprentices and trainees to journeymen shall not be greater than permitted by the terms of the particular program.

5. Compliance with Copeland Act requirements. The contractor shall comply with the requirements of 29 CFR part 3, which are incorporated by reference in this contract.

6. Subcontracts. The contractor or subcontractor shall insert Form FHWA-1273 in any subcontracts and also require the subcontractors to include Form FHWA-1273 in any lower tier subcontracts. The prime contractor shall be responsible for the compliance by any subcontractor or lower tier subcontractor with all the contract clauses in 29 CFR 5.5.

7. Contract termination: debarment. A breach of the contract clauses in 29 CFR 5.5 may be grounds for termination of the contract, and for debarment as a contractor and a subcontractor as provided in 29 CFR 5.12.

8. Compliance with Davis-Bacon and Related Act requirements. All rulings and interpretations of the Davis-Bacon and Related Acts contained in 29 CFR parts 1, 3, and 5 are herein incorporated by reference in this contract.

9. Disputes concerning labor standards. Disputes arising out of the labor standards provisions of this contract shall not be subject to the general disputes clause of this contract. Such disputes shall be resolved in accordance with the procedures of the Department of Labor set forth in 29 CFR parts 5, 6, and 7. Disputes within the meaning of this clause include disputes between the contractor (or any of its subcontractors) and the contracting agency, the U.S. Department of Labor, or the employees or their representatives.

10. Certification of eligibility.

- a. By entering into this contract, the contractor certifies that neither it (nor he or she) nor any person or firm who has an interest in the contractor's firm is a person or firm ineligible to be awarded Government contracts by virtue of section 3(a) of the Davis-Bacon Act or 29 CFR 5.12(a)(1).
- b. No part of this contract shall be subcontracted to any person or firm ineligible for award of a Government contract by virtue of section 3(a) of the Davis-Bacon Act or 29 CFR 5.12(a)(1).
- c. The penalty for making false statements is prescribed in the U.S. Criminal Code, 18 U.S.C. 1001.

V. CONTRACT WORK HOURS AND SAFETY STANDARDS ACT

The following clauses apply to any Federal-aid construction contract in an amount in excess of \$100,000 and subject to the overtime provisions of the Contract Work Hours and Safety Standards Act. These clauses shall be inserted in addition to the clauses required by 29 CFR 5.5(a) or 29 CFR 4.6. As used in this paragraph, the terms laborers and mechanics include watchmen and guards.

- 1. Overtime requirements.** No contractor or subcontractor contracting for any part of the contract work which may require or involve the employment of laborers or mechanics shall require or permit any such laborer or mechanic in any workweek in which he or she is employed on such work to work in excess of forty hours in such workweek unless such laborer or mechanic receives compensation at a rate not less than one and one-half times the basic rate of pay for all hours worked in excess of forty hours in such workweek.
- 2. Violation; liability for unpaid wages; liquidated damages.** In the event of any violation of the clause set forth in paragraph (1.) of this section, the contractor and any subcontractor responsible therefor shall be liable for the unpaid wages. In addition, such contractor and subcontractor shall be liable to the United States (in the case of work done under contract for the District of Columbia or a territory, to such District or to such territory), for liquidated damages. Such liquidated damages shall be computed with respect to each individual laborer or mechanic, including watchmen and guards, employed in violation of the clause set forth in paragraph (1.) of this section, in the sum of \$10 for each calendar day on which such individual was required or permitted to work in excess of the standard workweek of forty hours without payment of the overtime wages required by the clause set forth in paragraph (1.) of this section.
- 3. Withholding for unpaid wages and liquidated damages.** The FHWA or the contracting agency shall upon its own action or upon written request of an authorized representative of the Department of Labor withhold or cause to be withheld, from any moneys payable on account of work performed by the contractor or subcontractor under any such contract or any other Federal contract with the same prime contractor, or any other federally-assisted contract subject to the Contract Work Hours and Safety Standards Act, which is held by the same prime contractor, such sums as may be determined to be necessary to satisfy any liabilities of such contractor or subcontractor for unpaid wages and liquidated damages as provided in the clause set forth in paragraph (2.) of this section.
- 4. Subcontracts.** The contractor or subcontractor shall insert in any subcontracts the clauses set forth in paragraph (1.) through (4.) of this section and also a clause requiring the subcontractors to include these clauses in any lower tier subcontracts. The prime contractor shall be responsible for compliance by any subcontractor or lower tier subcontractor with the clauses set forth in paragraphs (1.) through (4.) of this section.

VI. SUBLETTING OR ASSIGNING THE CONTRACT

This provision is applicable to all Federal-aid construction contracts on the National Highway System.

1. The contractor shall perform with its own organization contract work amounting to not less than 30 percent (or a greater percentage if specified elsewhere in the contract) of the total original contract price, excluding any specialty items designated by the contracting agency. Specialty items may be performed by subcontract and the amount of any such specialty items performed may be deducted from the total original contract price before computing the amount of work required to be performed by the contractor's own organization (23 CFR 635.116).

a. The term "perform work with its own organization" refers to workers employed or leased by the prime contractor, and equipment owned or rented by the prime contractor, with or without operators. Such term does not include employees or equipment of a subcontractor or lower tier subcontractor, agents of the prime contractor, or any other assignees. The term may include payments for the costs of hiring leased employees from an employee leasing firm meeting all relevant Federal and State regulatory requirements. Leased employees may only be included in this term if the prime contractor meets all of the following conditions:

(1) the prime contractor maintains control over the supervision of the day-to-day activities of the leased employees;

(2) the prime contractor remains responsible for the quality of the work of the leased employees;

(3) the prime contractor retains all power to accept or exclude individual employees from work on the project; and

(4) the prime contractor remains ultimately responsible for the payment of predetermined minimum wages, the submission of payrolls, statements of compliance and all other Federal regulatory requirements.

b. "Specialty Items" shall be construed to be limited to work that requires highly specialized knowledge, abilities, or equipment not ordinarily available in the type of contracting organizations qualified and expected to bid or propose on the contract as a whole and in general are to be limited to minor components of the overall contract.

2. The contract amount upon which the requirements set forth in paragraph (1) of Section VI is computed includes the cost of material and manufactured products which are to be purchased or produced by the contractor under the contract provisions.

3. The contractor shall furnish (a) a competent superintendent or supervisor who is employed by the firm, has full authority to direct performance of the work in accordance with the contract requirements, and is in charge of all construction operations (regardless of who performs the work) and (b) such other of its own organizational resources (supervision, management, and engineering services) as the contracting officer determines is necessary to assure the performance of the contract.

4. No portion of the contract shall be sublet, assigned or otherwise disposed of except with the written consent of the contracting officer, or authorized representative, and such consent when given shall not be construed to relieve the contractor of any responsibility for the fulfillment of the contract. Written consent will be given only after the

contracting agency has assured that each subcontract is evidenced in writing and that it contains all pertinent provisions and requirements of the prime contract.

5. The 30% self-performance requirement of paragraph (1) is not applicable to design-build contracts; however, contracting agencies may establish their own self-performance requirements.

VII. SAFETY: ACCIDENT PREVENTION

This provision is applicable to all Federal-aid construction contracts and to all related subcontracts.

1. In the performance of this contract the contractor shall comply with all applicable Federal, State, and local laws governing safety, health, and sanitation (23 CFR 635). The contractor shall provide all safeguards, safety devices and protective equipment and take any other needed actions as it determines, or as the contracting officer may determine, to be reasonably necessary to protect the life and health of employees on the job and the safety of the public and to protect property in connection with the performance of the work covered by the contract.

2. It is a condition of this contract, and shall be made a condition of each subcontract, which the contractor enters into pursuant to this contract, that the contractor and any subcontractor shall not permit any employee, in performance of the contract, to work in surroundings or under conditions which are unsanitary, hazardous or dangerous to his/her health or safety, as determined under construction safety and health standards (29 CFR 1926) promulgated by the Secretary of Labor, in accordance with Section 107 of the Contract Work Hours and Safety Standards Act (40 U.S.C. 3704).

3. Pursuant to 29 CFR 1926.3, it is a condition of this contract that the Secretary of Labor or authorized representative thereof, shall have right of entry to any site of contract performance to inspect or investigate the matter of compliance with the construction safety and health standards and to carry out the duties of the Secretary under Section 107 of the Contract Work Hours and Safety Standards Act (40 U.S.C.3704).

VIII. FALSE STATEMENTS CONCERNING HIGHWAY PROJECTS

This provision is applicable to all Federal-aid construction contracts and to all related subcontracts.

In order to assure high quality and durable construction in conformity with approved plans and specifications and a high degree of reliability on statements and representations made by engineers, contractors, suppliers, and workers on Federal-aid highway projects, it is essential that all persons concerned with the project perform their functions as carefully, thoroughly, and honestly as possible. Willful falsification, distortion, or misrepresentation with respect to any facts related to the project is a violation of Federal law. To prevent any misunderstanding regarding the seriousness of these and similar acts, Form FHWA-1022 shall be posted on each Federal-aid highway project (23 CFR 635) in one or more places where it is readily available to all persons concerned with the project:

18 U.S.C. 1020 reads as follows:

"Whoever, being an officer, agent, or employee of the United States, or of any State or Territory, or whoever, whether a person, association, firm, or corporation, knowingly makes any false statement, false representation, or false report as to the character, quality, quantity, or cost of the material used or to be used, or the quantity or quality of the work performed or to be performed, or the cost thereof in connection with the submission of plans, maps, specifications, contracts, or costs of construction on any highway or related project submitted for approval to the Secretary of Transportation; or

Whoever knowingly makes any false statement, false representation, false report or false claim with respect to the character, quality, quantity, or cost of any work performed or to be performed, or materials furnished or to be furnished, in connection with the construction of any highway or related project approved by the Secretary of Transportation; or

Whoever knowingly makes any false statement or false representation as to material fact in any statement, certificate, or report submitted pursuant to provisions of the Federal-aid Roads Act approved July 1, 1916, (39 Stat. 355), as amended and supplemented;

Shall be fined under this title or imprisoned not more than 5 years or both."

IX. IMPLEMENTATION OF CLEAN AIR ACT AND FEDERAL WATER POLLUTION CONTROL ACT

This provision is applicable to all Federal-aid construction contracts and to all related subcontracts.

By submission of this bid/proposal or the execution of this contract, or subcontract, as appropriate, the bidder, proposer, Federal-aid construction contractor, or subcontractor, as appropriate, will be deemed to have stipulated as follows:

1. That any person who is or will be utilized in the performance of this contract is not prohibited from receiving an award due to a violation of Section 508 of the Clean Water Act or Section 306 of the Clean Air Act.
2. That the contractor agrees to include or cause to be included the requirements of paragraph (1) of this Section X in every subcontract, and further agrees to take such action as the contracting agency may direct as a means of enforcing such requirements.

X. CERTIFICATION REGARDING DEBARMENT, SUSPENSION, INELIGIBILITY AND VOLUNTARY EXCLUSION

This provision is applicable to all Federal-aid construction contracts, design-build contracts, subcontracts, lower-tier subcontracts, purchase orders, lease agreements, consultant contracts or any other covered transaction requiring FHWA approval or that is estimated to cost \$25,000 or more – as defined in 2 CFR Parts 180 and 1200.

1. Instructions for Certification – First Tier Participants:

- a. By signing and submitting this proposal, the prospective first tier participant is providing the certification set out below.
- b. The inability of a person to provide the certification set out below will not necessarily result in denial of participation in this

covered transaction. The prospective first tier participant shall submit an explanation of why it cannot provide the certification set out below. The certification or explanation will be considered in connection with the department or agency's determination whether to enter into this transaction. However, failure of the prospective first tier participant to furnish a certification or an explanation shall disqualify such a person from participation in this transaction.

c. The certification in this clause is a material representation of fact upon which reliance was placed when the contracting agency determined to enter into this transaction. If it is later determined that the prospective participant knowingly rendered an erroneous certification, in addition to other remedies available to the Federal Government, the contracting agency may terminate this transaction for cause of default.

d. The prospective first tier participant shall provide immediate written notice to the contracting agency to whom this proposal is submitted if any time the prospective first tier participant learns that its certification was erroneous when submitted or has become erroneous by reason of changed circumstances.

e. The terms "covered transaction," "debarred," "suspended," "ineligible," "participant," "person," "principal," and "voluntarily excluded," as used in this clause, are defined in 2 CFR Parts 180 and 1200. "First Tier Covered Transactions" refers to any covered transaction between a grantee or subgrantee of Federal funds and a participant (such as the prime or general contract). "Lower Tier Covered Transactions" refers to any covered transaction under a First Tier Covered Transaction (such as subcontracts). "First Tier Participant" refers to the participant who has entered into a covered transaction with a grantee or subgrantee of Federal funds (such as the prime or general contractor). "Lower Tier Participant" refers any participant who has entered into a covered transaction with a First Tier Participant or other Lower Tier Participants (such as subcontractors and suppliers).

f. The prospective first tier participant agrees by submitting this proposal that, should the proposed covered transaction be entered into, it shall not knowingly enter into any lower tier covered transaction with a person who is debarred, suspended, declared ineligible, or voluntarily excluded from participation in this covered transaction, unless authorized by the department or agency entering into this transaction.

g. The prospective first tier participant further agrees by submitting this proposal that it will include the clause titled "Certification Regarding Debarment, Suspension, Ineligibility and Voluntary Exclusion-Lower Tier Covered Transactions," provided by the department or contracting agency, entering into this covered transaction, without modification, in all lower tier covered transactions and in all solicitations for lower tier covered transactions exceeding the \$25,000 threshold.

h. A participant in a covered transaction may rely upon a certification of a prospective participant in a lower tier covered transaction that is not debarred, suspended, ineligible, or voluntarily excluded from the covered transaction, unless it knows that the certification is erroneous. A participant is responsible for ensuring that its principals are not suspended, debarred, or otherwise ineligible to participate in covered transactions. To verify the eligibility of its principals, as well as the eligibility of any lower tier prospective participants, each participant may, but is not required to, check the Excluded Parties List System website (<https://www.epls.gov/>), which is compiled by the General Services Administration.

i. Nothing contained in the foregoing shall be construed to require the establishment of a system of records in order to render in good faith the certification required by this clause. The knowledge and information of the prospective participant is not required to exceed that which is normally possessed by a prudent person in the ordinary course of business dealings.

j. Except for transactions authorized under paragraph (f) of these instructions, if a participant in a covered transaction knowingly enters into a lower tier covered transaction with a person who is suspended, debarred, ineligible, or voluntarily excluded from participation in this transaction, in addition to other remedies available to the Federal Government, the department or agency may terminate this transaction for cause or default.

* * * * *

2. Certification Regarding Debarment, Suspension, Ineligibility and Voluntary Exclusion – First Tier Participants:

a. The prospective first tier participant certifies to the best of its knowledge and belief, that it and its principals:

(1) Are not presently debarred, suspended, proposed for debarment, declared ineligible, or voluntarily excluded from participating in covered transactions by any Federal department or agency;

(2) Have not within a three-year period preceding this proposal been convicted of or had a civil judgment rendered against them for commission of fraud or a criminal offense in connection with obtaining, attempting to obtain, or performing a public (Federal, State or local) transaction or contract under a public transaction; violation of Federal or State antitrust statutes or commission of embezzlement, theft, forgery, bribery, falsification or destruction of records, making false statements, or receiving stolen property;

(3) Are not presently indicted for or otherwise criminally or civilly charged by a governmental entity (Federal, State or local) with commission of any of the offenses enumerated in paragraph (a)(2) of this certification; and

(4) Have not within a three-year period preceding this application/proposal had one or more public transactions (Federal, State or local) terminated for cause or default.

b. Where the prospective participant is unable to certify to any of the statements in this certification, such prospective participant shall attach an explanation to this proposal.

2. Instructions for Certification - Lower Tier Participants:

(Applicable to all subcontracts, purchase orders and other lower tier transactions requiring prior FHWA approval or estimated to cost \$25,000 or more - 2 CFR Parts 180 and 1200)

a. By signing and submitting this proposal, the prospective lower tier is providing the certification set out below.

b. The certification in this clause is a material representation of fact upon which reliance was placed when this transaction was entered into. If it is later determined that the prospective lower tier participant knowingly rendered an erroneous certification, in addition to other remedies available to the Federal Government, the department, or agency with which

this transaction originated may pursue available remedies, including suspension and/or debarment.

c. The prospective lower tier participant shall provide immediate written notice to the person to which this proposal is submitted if at any time the prospective lower tier participant learns that its certification was erroneous by reason of changed circumstances.

d. The terms "covered transaction," "debarred," "suspended," "ineligible," "participant," "person," "principal," and "voluntarily excluded," as used in this clause, are defined in 2 CFR Parts 180 and 1200. You may contact the person to which this proposal is submitted for assistance in obtaining a copy of those regulations. "First Tier Covered Transactions" refers to any covered transaction between a grantee or subgrantee of Federal funds and a participant (such as the prime or general contract). "Lower Tier Covered Transactions" refers to any covered transaction under a First Tier Covered Transaction (such as subcontracts). "First Tier Participant" refers to the participant who has entered into a covered transaction with a grantee or subgrantee of Federal funds (such as the prime or general contractor). "Lower Tier Participant" refers any participant who has entered into a covered transaction with a First Tier Participant or other Lower Tier Participants (such as subcontractors and suppliers).

e. The prospective lower tier participant agrees by submitting this proposal that, should the proposed covered transaction be entered into, it shall not knowingly enter into any lower tier covered transaction with a person who is debarred, suspended, declared ineligible, or voluntarily excluded from participation in this covered transaction, unless authorized by the department or agency with which this transaction originated.

f. The prospective lower tier participant further agrees by submitting this proposal that it will include this clause titled "Certification Regarding Debarment, Suspension, Ineligibility and Voluntary Exclusion-Lower Tier Covered Transaction," without modification, in all lower tier covered transactions and in all solicitations for lower tier covered transactions exceeding the \$25,000 threshold.

g. A participant in a covered transaction may rely upon a certification of a prospective participant in a lower tier covered transaction that is not debarred, suspended, ineligible, or voluntarily excluded from the covered transaction, unless it knows that the certification is erroneous. A participant is responsible for ensuring that its principals are not suspended, debarred, or otherwise ineligible to participate in covered transactions. To verify the eligibility of its principals, as well as the eligibility of any lower tier prospective participants, each participant may, but is not required to, check the Excluded Parties List System website (<https://www.epls.gov/>), which is compiled by the General Services Administration.

h. Nothing contained in the foregoing shall be construed to require establishment of a system of records in order to render in good faith the certification required by this clause. The knowledge and information of participant is not required to exceed that which is normally possessed by a prudent person in the ordinary course of business dealings.

i. Except for transactions authorized under paragraph e of these instructions, if a participant in a covered transaction knowingly enters into a lower tier covered transaction with a person who is suspended, debarred, ineligible, or voluntarily excluded from participation in this transaction, in addition to other remedies available to the Federal Government, the

department or agency with which this transaction originated may pursue available remedies, including suspension and/or debarment.

* * * * *

Certification Regarding Debarment, Suspension, Ineligibility and Voluntary Exclusion--Lower Tier Participants:

1. The prospective lower tier participant certifies, by submission of this proposal, that neither it nor its principals is presently debarred, suspended, proposed for debarment, declared ineligible, or voluntarily excluded from participating in covered transactions by any Federal department or agency.

2. Where the prospective lower tier participant is unable to certify to any of the statements in this certification, such prospective participant shall attach an explanation to this proposal.

* * * * *

XI. CERTIFICATION REGARDING USE OF CONTRACT FUNDS FOR LOBBYING

This provision is applicable to all Federal-aid construction contracts and to all related subcontracts which exceed \$100,000 (49 CFR 20).

1. The prospective participant certifies, by signing and submitting this bid or proposal, to the best of his or her knowledge and belief, that:

a. No Federal appropriated funds have been paid or will be paid, by or on behalf of the undersigned, to any person for influencing or attempting to influence an officer or employee of any Federal agency, a Member of Congress, an officer or employee of Congress, or an employee of a Member of Congress in connection with the awarding of any Federal contract, the making of any Federal grant, the making of any Federal loan, the entering into of any cooperative agreement, and the extension, continuation, renewal, amendment, or modification of any Federal contract, grant, loan, or cooperative agreement.

b. If any funds other than Federal appropriated funds have been paid or will be paid to any person for influencing or attempting to influence an officer or employee of any Federal agency, a Member of Congress, an officer or employee of Congress, or an employee of a Member of Congress in connection with this Federal contract, grant, loan, or cooperative agreement, the undersigned shall complete and submit Standard Form-LLL, "Disclosure Form to Report Lobbying," in accordance with its instructions.

2. This certification is a material representation of fact upon which reliance was placed when this transaction was made or entered into. Submission of this certification is a prerequisite for making or entering into this transaction imposed by 31 U.S.C. 1352. Any person who fails to file the required certification shall be subject to a civil penalty of not less than \$10,000 and not more than \$100,000 for each such failure.

3. The prospective participant also agrees by submitting its bid or proposal that the participant shall require that the language of this certification be included in all lower tier subcontracts, which exceed \$100,000 and that all such recipients shall certify and disclose accordingly.

Female and Minority Goals

To comply with Section II, "Nondiscrimination," of "Required Contract Provisions Federal-Aid Construction Contracts" (FHWA-1273), the following are the female and minority utilization goals for Federal-aid construction contracts and subcontracts that exceed \$10,000.

The nationwide goal for female utilization is 6.9 percent.

The goals for minority utilization [45 Fed Reg 65984 (10/3/1980)] are as follows:

Minority Utilization Goals

Economic Area		Goal (Percent)
174	Redding CA: Non-SMSA Counties: CA Lassen; CA Modoc; CA Plumas; CA Shasta; CA Siskiyou; CA Tehama	6.8
175	Eureka, CA Non-SMSA Counties: CA Del Norte; CA Humboldt; CA Trinity	6.6
176	San Francisco-Oakland-San Jose, CA: SMSA Counties: 7120 Salinas-Seaside-Monterey, CA	28.9
	CA Monterey	
	7360 San Francisco-Oakland	25.6
	CA Alameda; CA Contra Costa; CA Marin; CA San Francisco; CA San Mateo	
	7400 San Jose, CA	
	CA Santa Clara, CA	19.6
	7485 Santa Cruz, CA	
	CA Santa Cruz	14.9
	7500 Santa Rosa	
CA Sonoma	9.1	
8720 Vallejo-Fairfield-Napa, CA		
CA Napa; CA Solano	17.1	
Non-SMSA Counties: CA Lake; CA Mendocino; CA San Benito	23.2	
177	Sacramento, CA: SMSA Counties: 6920 Sacramento, CA	16.1
	CA Placer; CA Sacramento; CA Yolo	
	Non-SMSA Counties CA Butte; CA Colusa; CA El Dorado; CA Glenn; CA Nevada; CA Sierra; CA Sutter; CA Yuba	14.3
178	Stockton-Modesto, CA: SMSA Counties: 5170 Modesto, CA	12.3
	CA Stanislaus 8120	
	Stockton, CA CA	24.3
	San Joaquin	
	Non-SMSA Counties CA Alpine; CA Amador; CA Calaveras; CA Mariposa; CA Merced; CA Toulumne	19.8
179	Fresno-Bakersfield, CA SMSA Counties: 0680 Bakersfield, CA	19.1
	CA Kern	
	2840 Fresno, CA	26.1
	CA Fresno	
	Non-SMSA Counties:	23.6

	CA Kings; CA Madera; CA Tulare	
180	Los Angeles, CA: SMSA Counties: 0360 Anaheim-Santa Ana-Garden Grove, CA CA Orange 4480 Los Angeles-Long Beach, CA CA Los Angeles 6000 Oxnard-Simi Valley-Ventura, CA CA Ventura 6780 Riverside-San Bernardino-Ontario, CA CA Riverside; CA San Bernardino 7480 Santa Barbara-Santa Maria-Lompoc, CA CA Santa Barbara Non-SMSA Counties CA Inyo; CA Mono; CA San Luis Obispo	11.9 28.3 21.5 19.0 19.7 24.6
181	San Diego, CA: SMSA Counties 7320 San Diego, CA CA San Diego Non-SMSA Counties CA Imperial	16.9 18.2

For each July during which work is performed under the contract, you and each non-material-supplier subcontractor with a subcontract of \$10,000 or more must complete Form FHWA PR-1391 (Appendix C to 23 CFR 230). Submit the forms by August 15.

Federal Trainee Program

This section applies if a number of trainees or apprentices is specified in the Special Provisions.

As part of your equal opportunity affirmative action program, provide on-the-job training to develop full journeymen in the types of trades or job classifications involved.

You have primary responsibility for meeting this training requirement.

If you subcontract a contract part, determine how many trainees or apprentices are to be trained by the subcontractor.

Include these training requirements in your subcontract.

Where feasible, 25 percent of apprentices or trainees in each occupation must be in their 1st year of apprenticeship or training.

Distribute the number of apprentices or trainees among the work classifications on the basis of your needs and the availability of journeymen in the various classifications within a reasonable recruitment area.

Before starting work, submit to the County:

1. Number of apprentices or trainees to be trained for each classification
2. Training program to be used
3. Training starting date for each classification

Obtain the County's approval for this submitted information before you start work. The County credits you for each apprentice or trainee you employ on the work who is currently enrolled or becomes enrolled in an approved program. The primary objective of this section is to train and upgrade minorities and women toward journeymen status. Make every effort to enroll minority and women apprentices or trainees, such as conducting systematic and direct recruitment through public and private sources likely to yield minority and women apprentices or trainees, to the extent they are available within a reasonable recruitment area. Show that you have made the efforts. In making these efforts, do not discriminate against any applicant for training.

Do not employ as an apprentice or trainee an employee:

1. In any classification in which the employee has successfully completed a training course leading to journeyman status or in which the employee has been employed as a journeyman
2. Who is not registered in a program approved by the US Department of Labor, Bureau of Apprenticeship and Training

Ask the employee if the employee has successfully completed a training course leading to journeyman status or has been employed as a journeyman. Your records must show the employee's answers to the questions.

In your training program, establish the minimum length and training type for each classification. The County and FHWA approves a program if one of the following is met:

1. It is calculated to:
 - 1.1. Meet the your equal employment opportunity responsibilities
 - 1.2. Qualify the average apprentice or trainee for journeyman status in the classification involved by the end of the training period
2. It is registered with the U.S. Department of Labor, Bureau of Apprenticeship and Training and it is administered in a way consistent with the equal employment responsibilities of federal-aid highway construction contracts

Obtain the State's approval for your training program before you start work involving the classification covered by the program. Provide training in the construction crafts, not in clerk-typist or secretarial-type positions. Training is allowed in lower level management positions such as office engineers, estimators, and timekeepers if the training is oriented toward construction applications. Training is allowed in the laborer classification if significant and meaningful training is provided and approved by the division office. Off-site training is allowed if the training is an integral part of an approved training program and does not make up a significant part of the overall training.

The County reimburses you 80 cents per hour of training given an employee on this contract under an approved training program:

1. For on-site training
2. For off-site training if the apprentice or trainee is currently employed on a federal-aid project and you do at least one of the following:
 - 2.1. Contribute to the cost of the training
 - 2.2. Provide the instruction to the apprentice or trainee
 - 2.3. Pay the apprentice's or trainee's wages during the off-site training period
3. If you comply with this section.

Each apprentice or trainee must:

1. Begin training on the project as soon as feasible after the start of work involving the apprentice's or trainee's skill
2. Remain on the project as long as training opportunities exist in the apprentice's or trainee's work classification or until the apprentice or trainee has completed the training program

Furnish the apprentice or trainee:

1. Copy of the program you will comply with in providing the training