

SIGNING AND STRIPING CONSTRUCTION NOTES: (THIS SHEET ONLY)

- 1 PAINT DOUBLE-YELLOW STRIPE PER CALTRANS 2018 STD. PLAN A20A, DETAIL 22.
- 2 PAINT 6-INCH SOLID WHITE EDGE LINE PER CALTRANS 2018 STD. PLAN A20B, DETAIL 27B.
- 3 PAINT 12-INCH WHITE LIMIT LINE PER CALTRANS 2018 STD. PLAN A24E.
- 6 PAINT WHITE PAVEMENT MARKING LEGEND PER CALTRANS 2018 STD. PLAN A24D, (TYPE PER PLAN).
- 7 PAINT TYPE IV LEFT OR RIGHT TURN ARROW PAVEMENT MARKING PER CALTRANS 2018 STD. PLAN A24A.
- 9 PAINT 8-INCH SOLID WHITE CHANNELIZING LINE PER CALTRANS 2018 STD. PLAN A20D, DETAIL 38.
- 10 PAINT 12-INCH WHITE HATCHING MARKINGS AT 45° AND 100' (OR AS SHOWN) SPACING PER CA MUTCD 2014, SEC.3B.24.
- 13 PAINT 6-INCH DOUBLE-YELLOW MEDIAN ISLAND STRIPE PER CALTRANS 2018 STD. PLAN A20B DETAIL 29.
- 14 PAINT TWO WAY LEFT TURN LANE PER CALTRANS 2018 STD. PLAN A20B, DETAIL 32.
- 17 PAINT WHITE PAVEMENT MARKING LEGEND PER CALTRANS 2018 STD. PLAN A24C, (TYPE PER PLAN).
- 28 INSTALL FIRE HYDRANT BLUE PAVEMENT MARKER PER CA MUTCD 2014, FIGURE 3B-102 (CA).
- 31 ALL EXISTING SIGNS TO BE PROTECTED IN PLACE UNLESS OTHERWISE SPECIFIED.
- 34 INSTALL TYPE L-1(CA) OM2-2V OBJECT MARKER PER THE CA MUTCD 2014, FIG 2C-13(CA)
- M MATCH/JOIN EXISTING
- S SIGNALIZED INTERSECTION

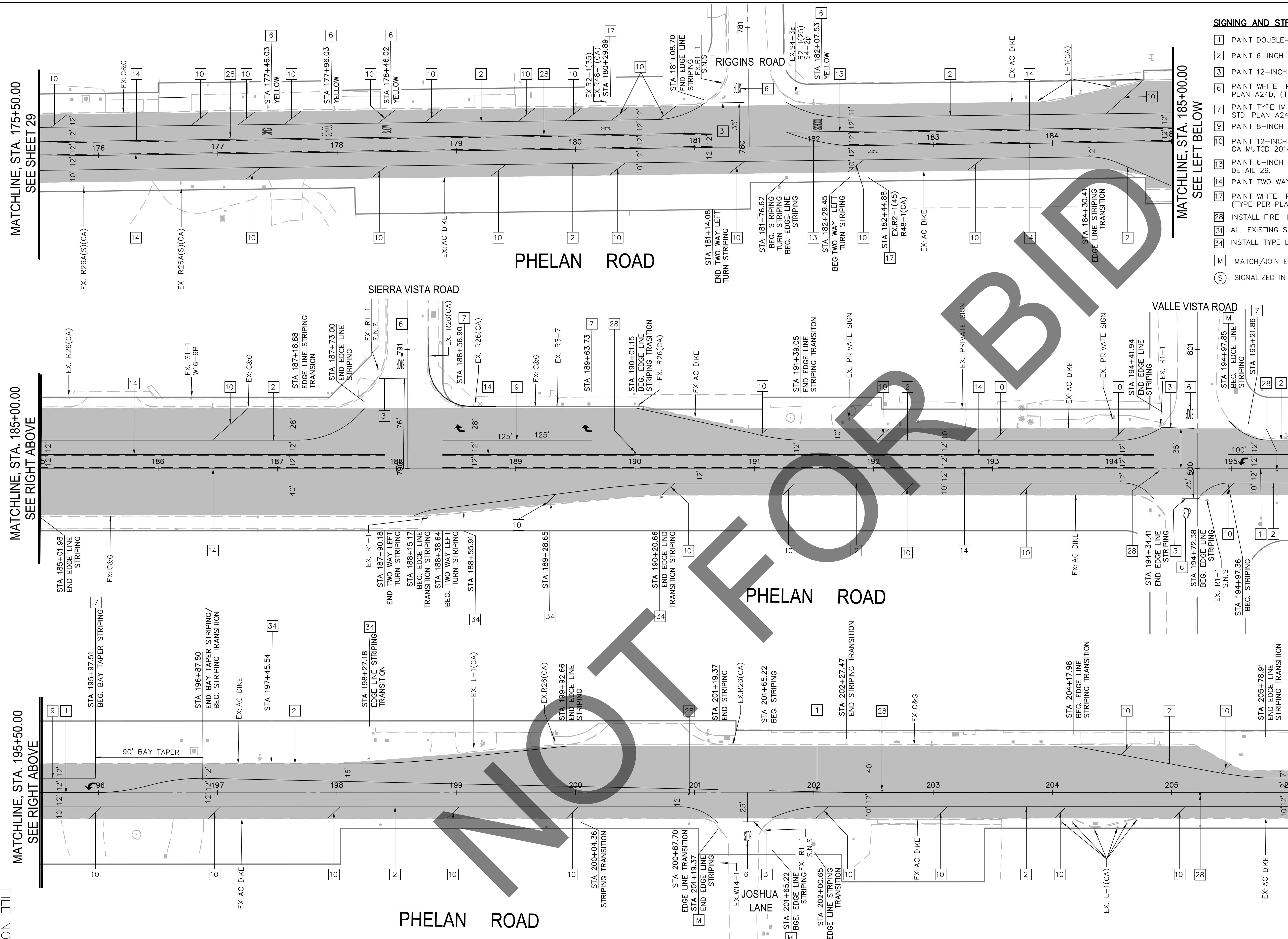

MATCHLINE, STA. 175+50.00
SEE SHEET 29

MATCHLINE, STA. 185+00.00
SEE RIGHT ABOVE

MATCHLINE, STA. 195+50.00
SEE RIGHT ABOVE

MATCHLINE, STA. 185+00.00
SEE LEFT BELOW

MATCHLINE, STA. 195+50.00
SEE LEFT BELOW

MATCHLINE, STA. 206+00.00
SEE SHEET 31

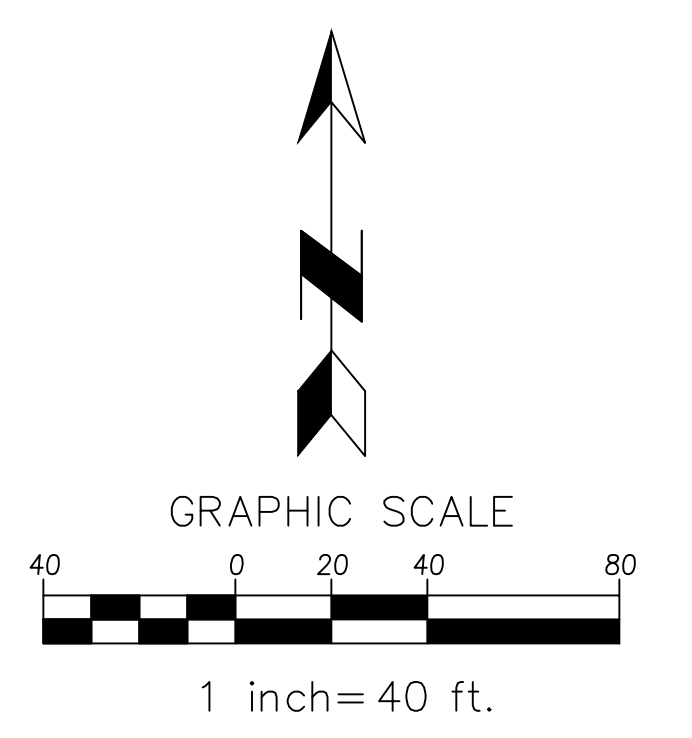

NOTE: ALL PAVEMENT MARKERS FOR INSTALLATION WITH TRAFFIC STRIPES AND FIRE HYDRANTS SHALL BE RECESSED. RECESSED PAVEMENT MARKERS SHALL BE INSTALLED IN ACCORDANCE WITH CALTRANS STANDARD PLAN A20D, AND AS SPECIFIED IN THE SPECIAL PROVISIONS.

Underground Service Alert
Call: TOLL FREE
1-800-227-2600
TWO WORKING DAYS BEFORE YOU DIG

MARK	CHANGES	RESIDENT ENGINEER	DATE
	NO CHANGES		

FIELD CHANGES

SAN BERNARDINO COUNTY
DEPARTMENT OF PUBLIC WORKS

DESIGNED BY: CG/JHC	DRAWN BY: CG	CHECKED BY: JHC/LL	RECOMMENDED BY: ANTHONY PHAM, P.E. ENGINEERING MANAGER, TRAFFIC DIVISION
APPROVED BY: GRANT MANN, P.E. DEPUTY DIRECTOR			7/1/2024 DATE
DATE: 7/2/2024			DATE: 7/3/2024

PHELAN ROAD				
SIGNING AND STRIPING PLAN				
PHELAN AREA				
J.L. REF. J.L.#XXXX	W.O. NO. H15269	PLAN SCALE AS SHOWN	SHT. NO. 30	TOT. SHT'S. 43

MARK	REVISIONS	DATE	APPR.

SIGNING AND STRIPING CONSTRUCTION NOTES: (THIS SHEET ONLY)

- 1 PAINT DOUBLE-YELLOW STRIPE PER CALTRANS 2018 STD. PLAN A20A, DETAIL 22.
 - 2 PAINT 6-INCH SOLID WHITE EDGE LINE PER CALTRANS 2018 STD. PLAN A20B, DETAIL 27B.
 - 5 PAINT TYPE VI LANE DROP ARROW PAVEMENT MARKING PER CALTRANS 2018 STD. PLAN A24A.
 - 6 PAINT WHITE PAVEMENT MARKING LEGEND PER CALTRANS 2018 STD. PLAN A24D, (TYPE PER PLAN).
 - 7 PAINT TYPE IV LEFT OR RIGHT TURN ARROW PAVEMENT MARKING PER CALTRANS 2018 STD. PLAN A24A.
 - 8 PAINT 6-INCH SOLID WHITE LINE.
 - 9 PAINT 8-INCH SOLID WHITE CHANNELIZING LINE PER CALTRANS 2018 STD. PLAN A20D, DETAIL 38.
 - 10 PAINT 12-INCH WHITE HATCHING MARKINGS AT 45° AND 100' (OR AS SHOWN) SPACING PER CA MUTCD 2014, SEC.3B.24.
 - 11 PAINT 6-INCH DASHED YELLOW LINE PER CALTRANS 2018 STD. PLAN A20A, DETAIL 6.
 - 16 PAINT 12-INCH SOLID WHITE CROSSWALK PER CALTRANS 2018 STD. PLAN A24F, BASIC AND DETAIL B OF CALTRANS A88A WHERE APPLICABLE.
 - 17 PAINT WHITE PAVEMENT MARKING LEGEND PER CALTRANS 2018 STD. PLAN A24C, (TYPE PER PLAN).
 - 26 INSTALL NEW SIGN(S) AS SHOWN ON PLAN AND PER CA MUTCD 2014, FIGURES 2A-2(CA) AND 2A-3.
 - 28 INSTALL FIRE HYDRANT BLUE PAVEMENT MARKER PER CA MUTCD 2014, FIGURE 3B-102 (CA).
 - 29 PAINT 6-INCH DASHED WHITE LINE PER CALTRANS 2018 STD. PLAN A20A, DETAIL 12.
 - 31 ALL EXISTING SIGNS TO BE PROTECTED IN PLACE UNLESS OTHERWISE SPECIFIED.
- P PROTECT IN PLACE
 - M MATCH/JOIN EXISTING
 - S SIGNALIZED INTERSECTION

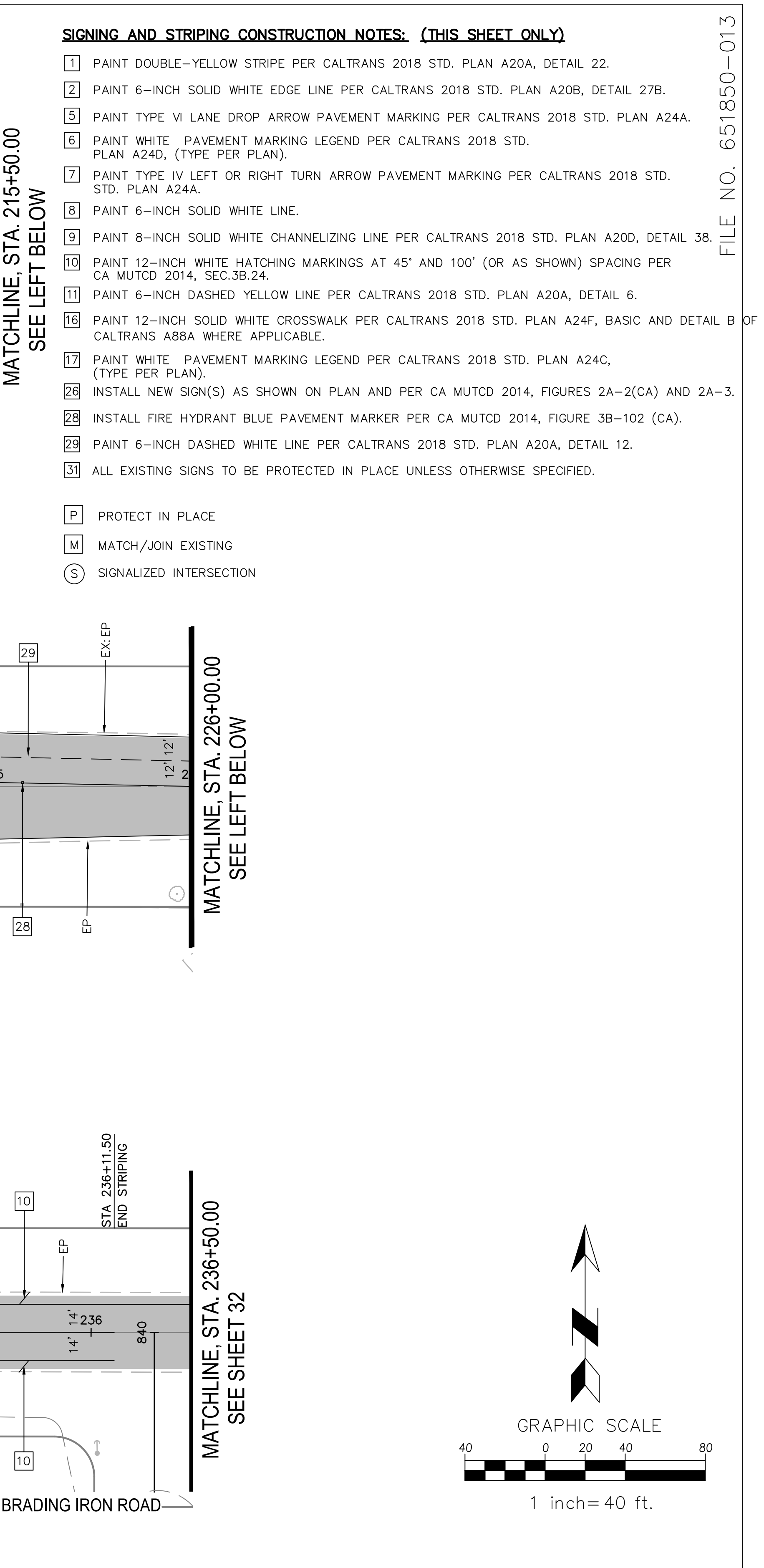
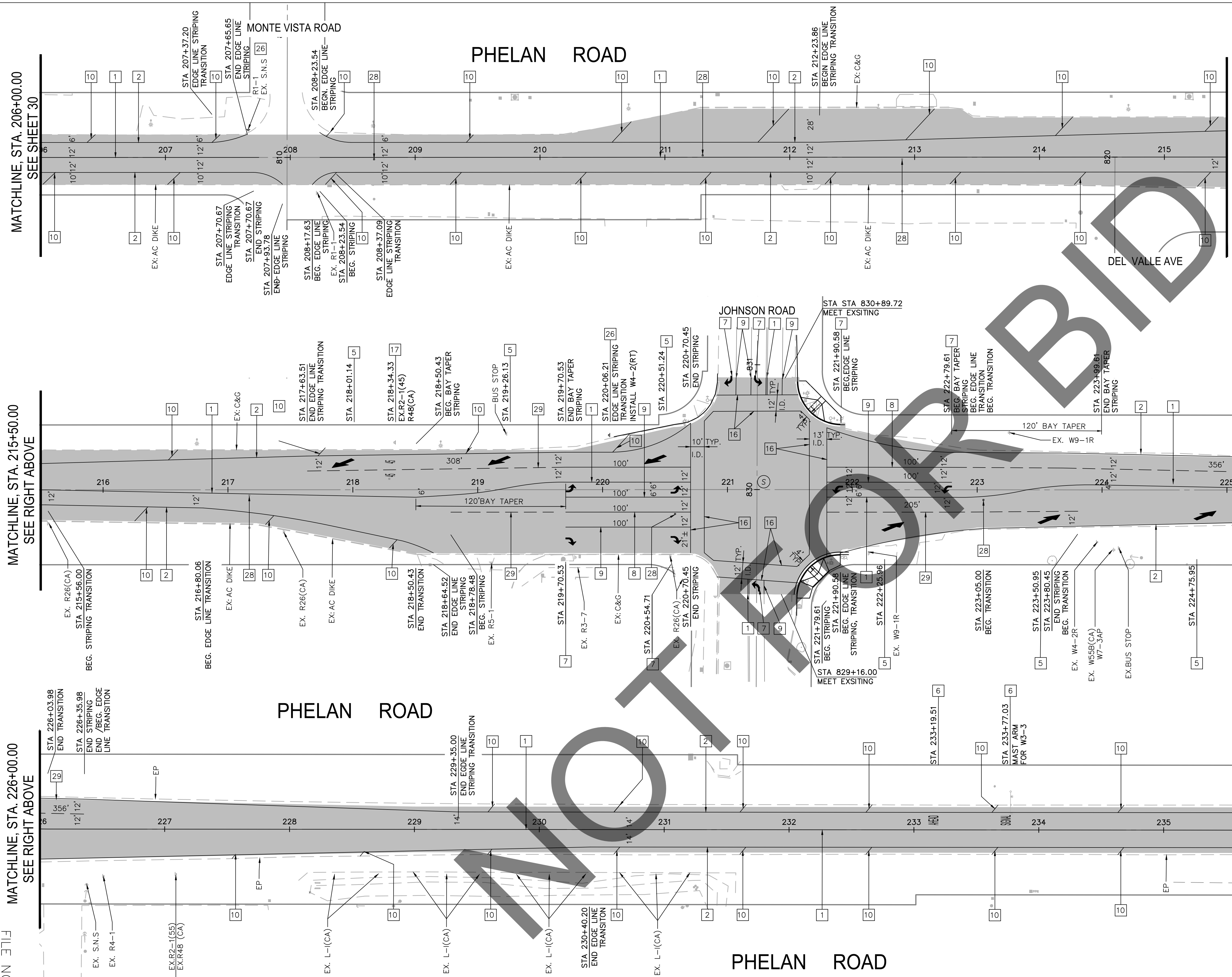

MARK	REVISIONS	APPR.	DATE

NOTE: ALL PAVEMENT MARKERS FOR INSTALLATION WITH TRAFFIC STRIPES AND FIRE HYDRANTS SHALL BE RECESSED. RECESSED PAVEMENT MARKERS SHALL BE INSTALLED IN ACCORDANCE WITH CALTRANS STANDARD PLAN A20D, AND AS SPECIFIED IN THE SPECIAL PROVISIONS.

Underground Service Alert

Call: TOLL FREE 1-800-227-2600

TWO WORKING DAYS BEFORE YOU DIG

MARK	CHANGES	RESIDENT ENGINEER	DATE
	NO CHANGES		

FIELD CHANGES

SAN BERNARDINO COUNTY
DEPARTMENT OF PUBLIC WORKS

DESIGNED BY: CG/JHC	DRAWN BY: CG	CHECKED BY: JHC/LL	RECOMMENDED BY: ANTHONY PHAM, P.E. ENGINEERING MANAGER, TRAFFIC DIVISION

APPROVED BY: GRANT MANN, P.E. DEPUTY DIRECTOR

DATE: 7/2/2024

PHELAN ROAD
SIGNING AND STRIPING PLAN
PHELAN AREA

J.L. REF. J.L.#XXXX	W.O. NO. H15269	PLAN SCALE AS SHOWN	SHT. NO. 31	TOT. SHT'S. 43
---------------------	-----------------	---------------------	-------------	----------------

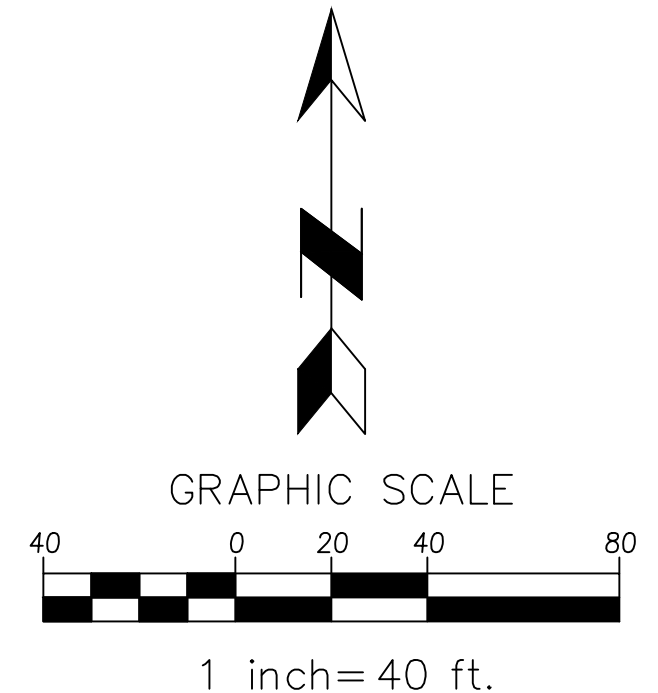

- SIGNING AND STRIPING CONSTRUCTION NOTES: (THIS SHEET ONLY)**
- 1 PAINT DOUBLE-YELLOW STRIPE PER CALTRANS 2018 STD. PLAN A20A, DETAIL 22.
 - 2 PAINT 6-INCH SOLID WHITE EDGE LINE PER CALTRANS 2018 STD. PLAN A20B, DETAIL 27B.
 - 3 PAINT 12-INCH WHITE LIMIT LINE PER CALTRANS 2018 STD. PLAN A24E.
 - 6 PAINT WHITE PAVEMENT MARKING LEGEND PER CALTRANS 2018 STD. PLAN A24D, (TYPE PER PLAN).
 - 7 PAINT TYPE IV LEFT OR RIGHT TURN ARROW PAVEMENT MARKING PER CALTRANS 2018 STD. PLAN A24A.
 - 9 PAINT 8-INCH SOLID WHITE CHANNELIZING LINE PER CALTRANS 2018 STD. PLAN A20D, DETAIL 38.
 - 10 PAINT 12-INCH WHITE HATCHING MARKINGS AT 45° AND 100' (OR AS SHOWN) SPACING PER CA MUTCD 2014, SEC.3B.24.
 - 11 PAINT 6-INCH DASHED YELLOW LINE PER CALTRANS 2018 STD. PLAN A20A, DETAIL 6.
 - 26 INSTALL NEW SIGN(S) AS SHOWN ON PLAN AND PER CA MUTCD 2014, FIGURES 2A-2(CA) AND 2A-3.
 - 28 INSTALL FIRE HYDRANT BLUE PAVEMENT MARKER PER CA MUTCD 2014, FIGURE 3B-102 (CA).
 - 31 ALL EXISTING SIGNS TO BE PROTECTED IN PLACE UNLESS OTHERWISE SPECIFIED.

- P PROTECT IN PLACE
- M MATCH/JOIN EXISTING

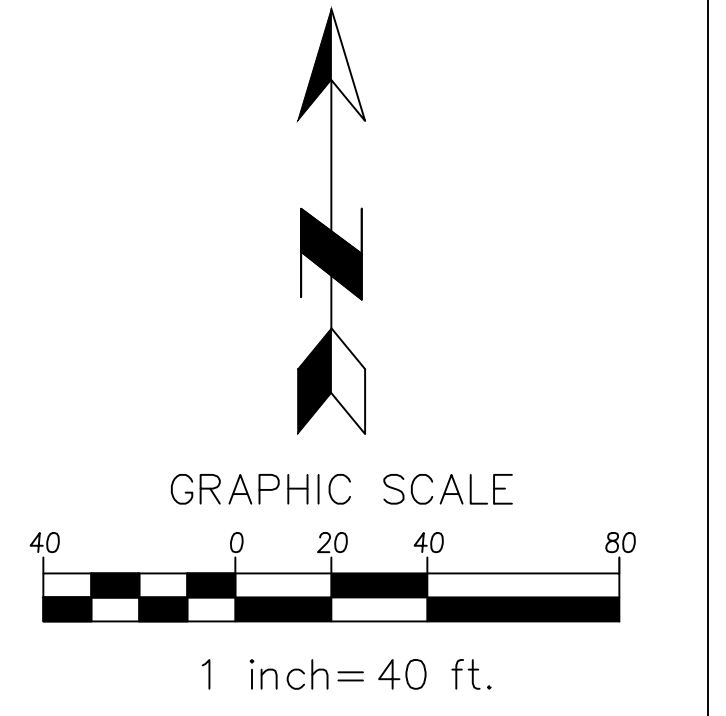
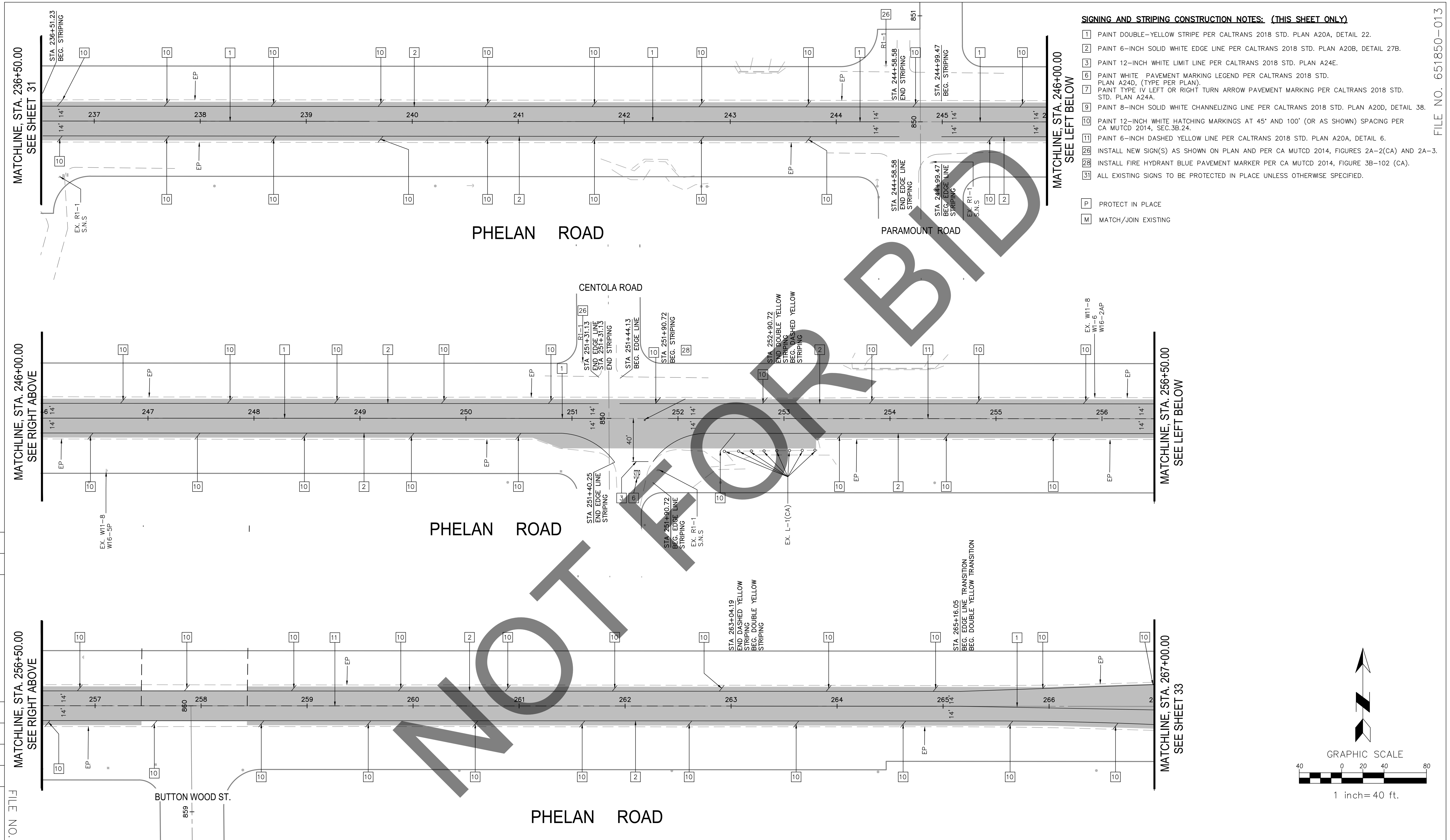

MARK	REVISIONS	APPR.	DATE

NOTE: ALL PAVEMENT MARKERS FOR INSTALLATION WITH TRAFFIC STRIPES AND FIRE HYDRANTS SHALL BE RECESSED. RECESSED PAVEMENT MARKERS SHALL BE INSTALLED IN ACCORDANCE WITH CALTRANS STANDARD PLAN A20D, AND AS SPECIFIED IN THE SPECIAL PROVISIONS.

Underground Service Alert
Call: TOLL FREE
1-800-227-2600
TWO WORKING DAYS BEFORE YOU DIG

MARK	CHANGES	RESIDENT ENGINEER	DATE
	NO CHANGES		

SAN BERNARDINO COUNTY
DEPARTMENT OF PUBLIC WORKS

DESIGNED BY: CG/JHC	DRAWN BY: CG	CHECKED BY: JHC/LL	RECOMMENDED BY: ANTHONY PHAM, P.E. ENGINEERING MANAGER, TRAFFIC DIVISION
			DATE: 7/1/2024
			APPROVED BY: GRANT MANN, P.E. DEPUTY DIRECTOR
			DATE: 7/3/2024

PHELAN ROAD				
SIGNING AND STRIPING PLAN				
PHELAN AREA				
J.L. REF. J.L.#XXXX	W.O. NO. H15269	PLAN SCALE AS SHOWN	SHT. NO. 32	TOT. SHT'S. 43

SIGNING AND STRIPING CONSTRUCTION NOTES: (THIS SHEET ONLY)

- 1 PAINT DOUBLE-YELLOW STRIPE PER CALTRANS 2018 STD. PLAN A20A, DETAIL 22.
 - 2 PAINT 6-INCH SOLID WHITE EDGE LINE PER CALTRANS 2018 STD. PLAN A20B, DETAIL 27B.
 - 3 PAINT 12-INCH WHITE LIMIT LINE PER CALTRANS 2018 STD. PLAN A24E.
 - 5 PAINT TYPE VI LANE DROP ARROW PAVEMENT MARKING PER CALTRANS 2018 STD. PLAN A24A.
 - 6 PAINT WHITE PAVEMENT MARKING LEGEND PER CALTRANS 2018 STD. PLAN A24D, (TYPE PER PLAN).
 - 7 PAINT TYPE IV LEFT OR RIGHT TURN ARROW PAVEMENT MARKING PER CALTRANS 2018 STD. PLAN A24A.
 - 9 PAINT 8-INCH SOLID WHITE CHANNELIZING LINE PER CALTRANS 2018 STD. PLAN A20D, DETAIL 38.
 - 19 PAINT TYPE I ARROW PAVEMENT MARKING PER CALTRANS 2018 STD. PLAN A24A
 - 28 INSTALL NEW SIGN(S) AS SHOWN ON PLAN AND PER CA MUTCD 2014, FIGURES 2A-2(CA) AND 2A-3.
 - 29 INSTALL FIRE HYDRANT BLUE PAVEMENT MARKER PER CA MUTCD 2014, FIGURE 3B-102 (CA).
 - 31 ALL EXISTING SIGNS TO BE PROTECTED IN PLACE UNLESS OTHERWISE SPECIFIED.
- M MATCH/JOIN EXISTING

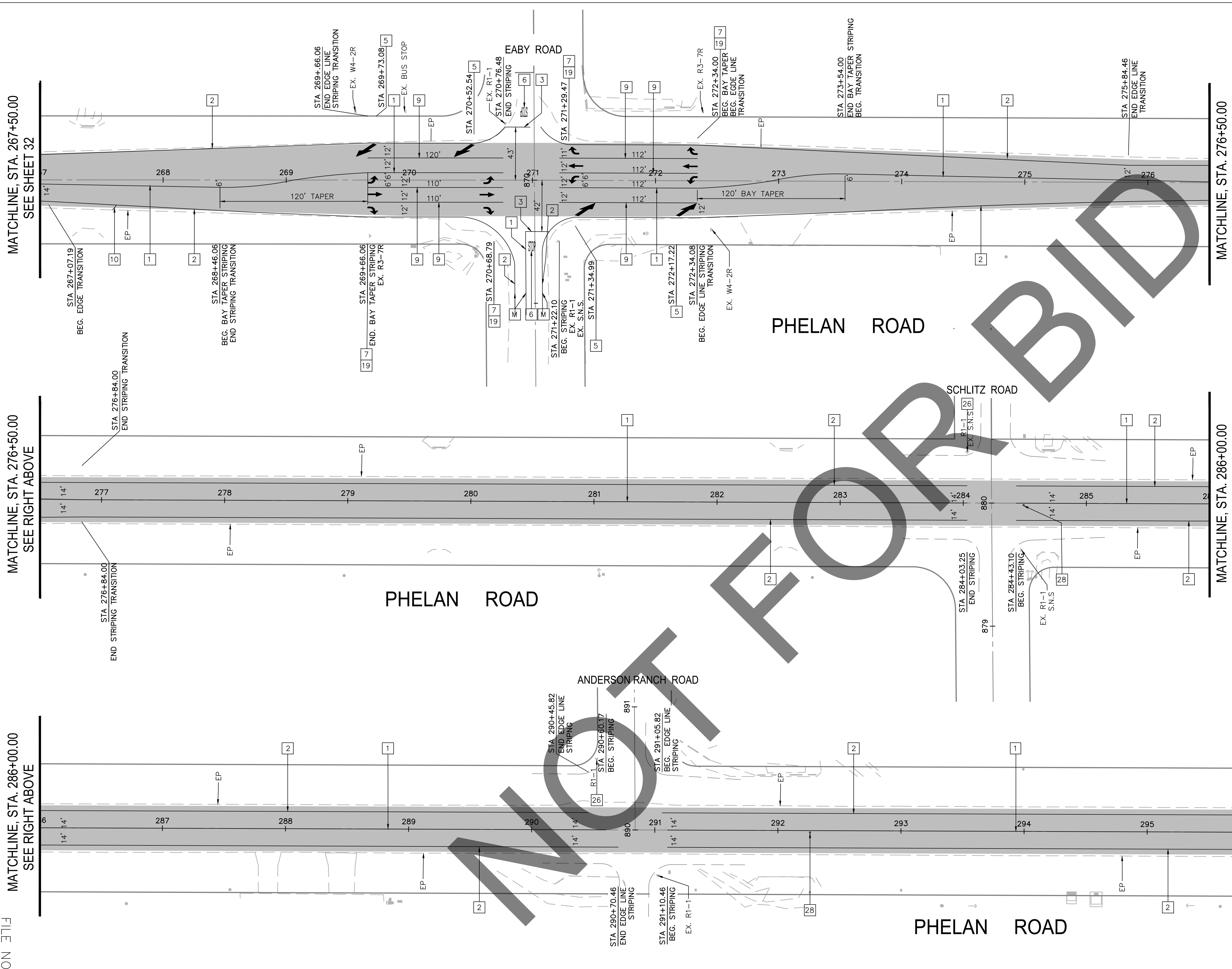

MATCHLINE, STA. 276+50.00
SEE SHEET BELOW

MATCHLINE, STA. 286+00.00
SEE LEFT BELOW

MATCHLINE, STA. 296+50.00
SEE SHEET 34

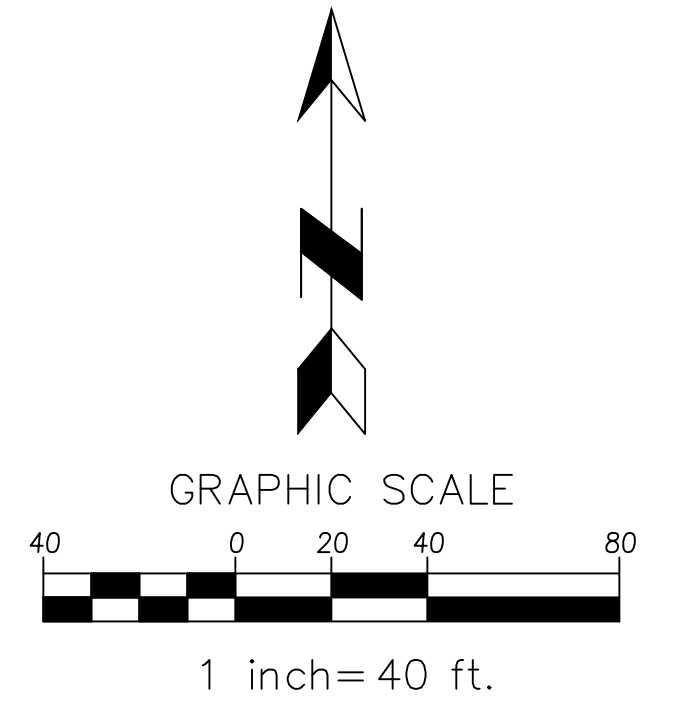

MARK	REVISIONS	DATE	APPR.

NOTE: ALL PAVEMENT MARKERS FOR INSTALLATION WITH TRAFFIC STRIPES AND FIRE HYDRANTS SHALL BE RECESSED. RECESSED PAVEMENT MARKERS SHALL BE INSTALLED IN ACCORDANCE WITH CALTRANS STANDARD PLAN A20D, AND AS SPECIFIED IN THE SPECIAL PROVISIONS.

<p>Underground Service Alert Call: TOLL FREE 1-800-227-2600</p>	<p>MARK CHANGES NO CHANGES</p>		<p>RESIDENT ENGINEER DATE</p>		<p>FIELD CHANGES</p>		<p>SAN BERNARDINO COUNTY DEPARTMENT OF PUBLIC WORKS</p>				<p>PHELAN ROAD SIGNING AND STRIPING PLAN PHELAN AREA</p>				
	DESIGNED BY: CG/JHC	DRAWN BY: CG	CHECKED BY: JHC/LL	RECOMMENDED BY: [Signature]			DATE: 7/1/2024	APPROVED BY: [Signature]	DATE: 7/3/2024	J.L. REF. J.L.#XXXX	W.O. NO. H15269	PLAN SCALE AS SHOWN	SHT. NO. 33	TOT. SHT'S. 43	
	<p>LEI LI, P.E. SUPERVISING ENGINEER</p>		DATE: 7/2/2024	<p>DATE: 7/3/2024</p>			<p>GRANT MANN, P.E. DEPUTY DIRECTOR</p>								

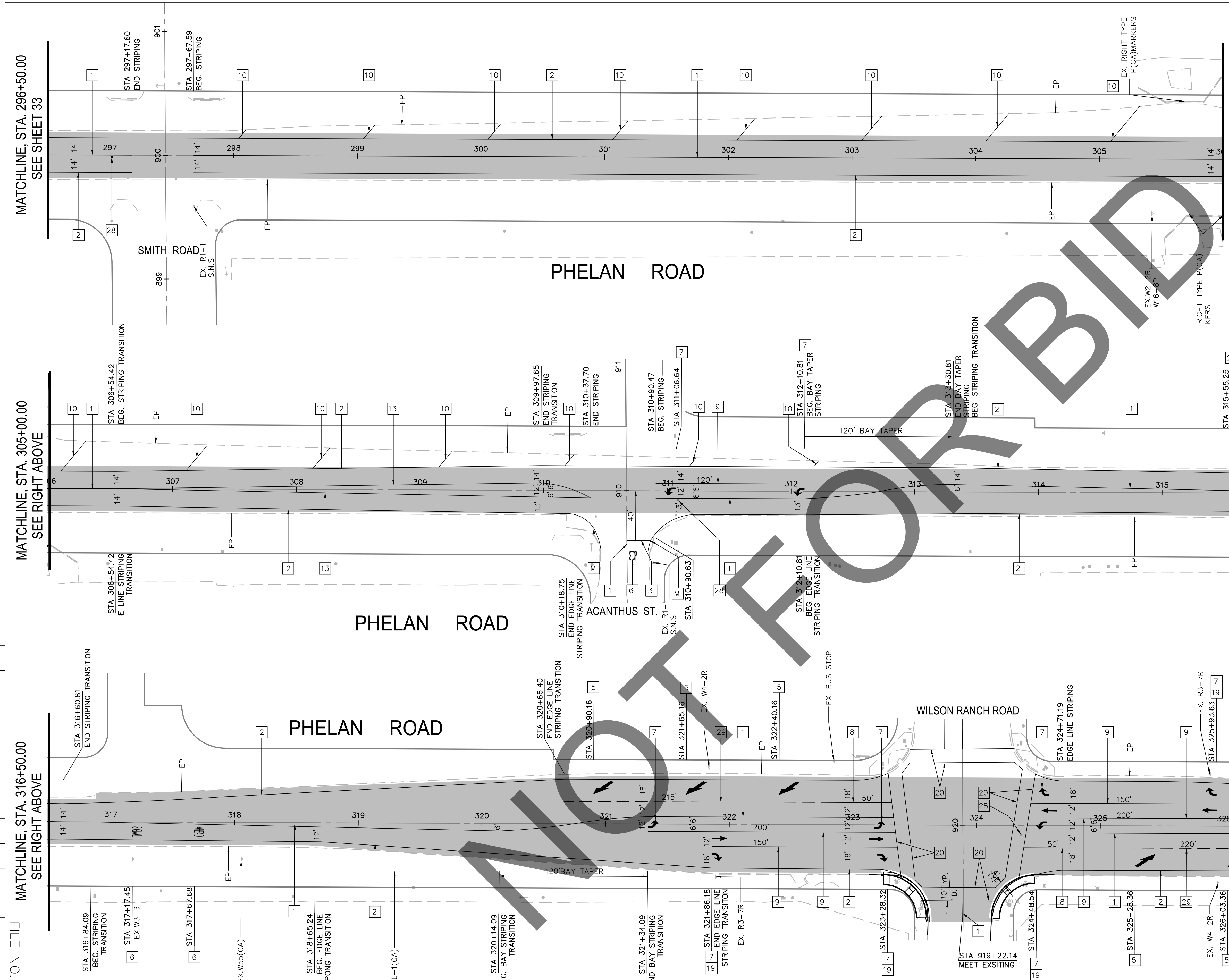

- SIGNING AND STRIPING CONSTRUCTION NOTES: (THIS SHEET ONLY)**
- 1 PAINT DOUBLE-YELLOW STRIPE PER CALTRANS 2018 STD. PLAN A20A, DETAIL 22.
 - 2 PAINT 6-INCH SOLID WHITE EDGE LINE PER CALTRANS 2018 STD. PLAN A20B, DETAIL 27B.
 - 3 PAINT 12-INCH WHITE LIMIT LINE PER CALTRANS 2018 STD. PLAN A24E.
 - 4 PAINT TYPE VI LANE DROP ARROW PAVEMENT MARKING PER CALTRANS 2018 STD. PLAN A24A.
 - 5 PAINT WHITE PAVEMENT MARKING LEGEND PER CALTRANS 2018 STD. PLAN A24D, (TYPE PER PLAN).
 - 6 PAINT TYPE IV LEFT OR RIGHT TURN ARROW PAVEMENT MARKING PER CALTRANS 2018 STD. PLAN A24A.
 - 7 PAINT 6-INCH SOLID WHITE LINE.
 - 8 PAINT 8-INCH SOLID WHITE CHANNELIZING LINE PER CALTRANS 2018 STD. PLAN A20D, DETAIL 38.
 - 9 PAINT 6-INCH DOUBLE-YELLOW MEDIAN ISLAND STRIPE PER CALTRANS 2018 STD. PLAN A20B DETAIL 29.
 - 10 PAINT 6-INCH DASHED WHITE LINE PER CALTRANS 2018 STD. PLAN A20A, DETAIL 9.
 - 11 PAINT TYPE I ARROW PAVEMENT MARKING PER CALTRANS 2018 STD. PLAN A24A
 - 12 PAINT SOLID YELLOW CROSSWALK PER CALTRANS 2018 STD. PLAN A24F, BASIC.
 - 13 INSTALL NEW SIGN(S) AS SHOWN ON PLAN AND PER CA MUTCD 2014, FIGURES 2A-2(CA) AND 2A-3.
 - 14 INSTALL FIRE HYDRANT BLUE PAVEMENT MARKER PER CA MUTCD 2014, FIGURE 3B-102 (CA).
 - 15 PAINT 6-INCH DASHED WHITE LINE PER CALTRANS 2018 STD. PLAN A20A, DETAIL 12.
 - 16 ALL EXISTING SIGNS TO BE PROTECTED IN PLACE UNLESS OTHERWISE SPECIFIED.
 - M MATCH/JOIN EXISTING
 - S SIGNALIZED INTERSECTION

MATCHLINE, STA. 296+50.00
SEE SHEET 33

MATCHLINE, STA. 305+00.00
SEE RIGHT ABOVE

MATCHLINE, STA. 316+50.00
SEE RIGHT ABOVE

MATCHLINE, STA. 305+00.00
SEE SHEET SEE LEFT BELOW

MATCHLINE, STA. 316+50.00
SEE LEFT BELOW

MATCHLINE, STA. 327+00.00
SEE SHEET 34

MARK	REVISIONS	DATE	APPR.

FILE NO. 651850-013

NOTE: ALL PAVEMENT MARKERS FOR INSTALLATION WITH TRAFFIC STRIPES AND FIRE HYDRANTS SHALL BE RECESSED. RECESSED PAVEMENT MARKERS SHALL BE INSTALLED IN ACCORDANCE WITH CALTRANS STANDARD PLAN A20D, AND AS SPECIFIED IN THE SPECIAL PROVISIONS.

Underground Service Alert

 Call: TOLL FREE 1-800-227-2600
 TWO WORKING DAYS BEFORE YOU DIG

MARK	CHANGES	RESIDENT ENGINEER	DATE
	NO CHANGES		

FIELD CHANGES

REGISTERED PROFESSIONAL ENGINEER
 ANTHONY PHAM
 CIVIL
 STATE OF CALIFORNIA
 C 76378

SAN BERNARDINO COUNTY
 DEPARTMENT OF PUBLIC WORKS

DESIGNED BY: CG/JHC	DRAWN BY: CG	CHECKED BY: JHC/LL	RECOMMENDED BY: ANTHONY PHAM, P.E. ENGINEERING MANAGER, TRAFFIC DIVISION
DATE: 7/2/2024	DATE: 7/2/2024	DATE: 7/2/2024	DATE: 7/1/2024

APPROVED BY: GRANT WANN, P.E. DEPUTY DIRECTOR
 DATE: 7/3/2024

PHELAN ROAD
 SIGNING AND STRIPING PLAN
 PHELAN AREA

J.L. REF. J.L.#XXXX	W.O. NO. H15269	PLAN SCALE AS SHOWN	SHT. NO. 34	TOT. SHT'S. 43
---------------------	-----------------	---------------------	-------------	----------------

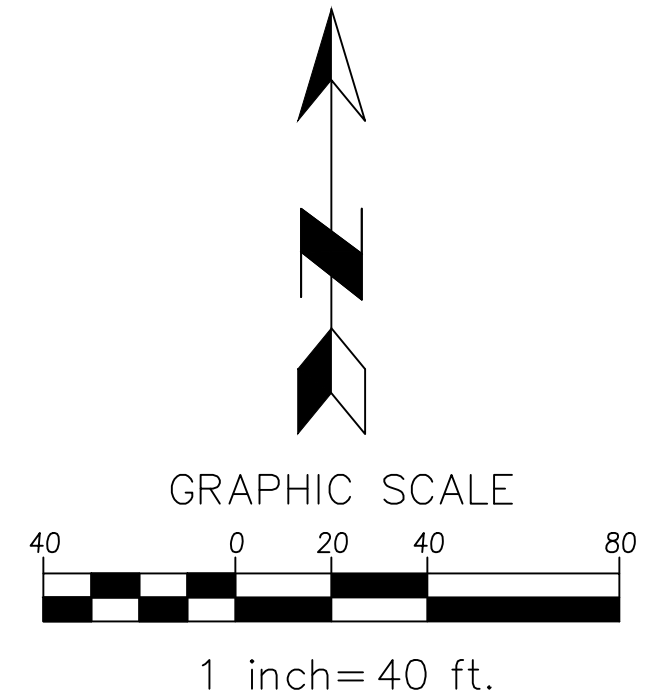

- SIGNING AND STRIPING CONSTRUCTION NOTES: (THIS SHEET ONLY)**
- 1 PAINT DOUBLE-YELLOW STRIPE PER CALTRANS 2018 STD. PLAN A20A, DETAIL 22.
 - 2 PAINT 6-INCH SOLID WHITE EDGE LINE PER CALTRANS 2018 STD. PLAN A20B, DETAIL 27B.
 - 6 PAINT WHITE PAVEMENT MARKING LEGEND PER CALTRANS 2018 STD. PLAN A24D, (TYPE PER PLAN).
 - 17 PAINT WHITE PAVEMENT MARKING LEGEND PER CALTRANS 2018 STD. PLAN A24C, (TYPE PER PLAN).
 - 31 ALL EXISTING SIGNS TO BE PROTECTED IN PLACE UNLESS OTHERWISE SPECIFIED.
- P PROTECT IN PLACE
M MATCH/JOIN EXISTING

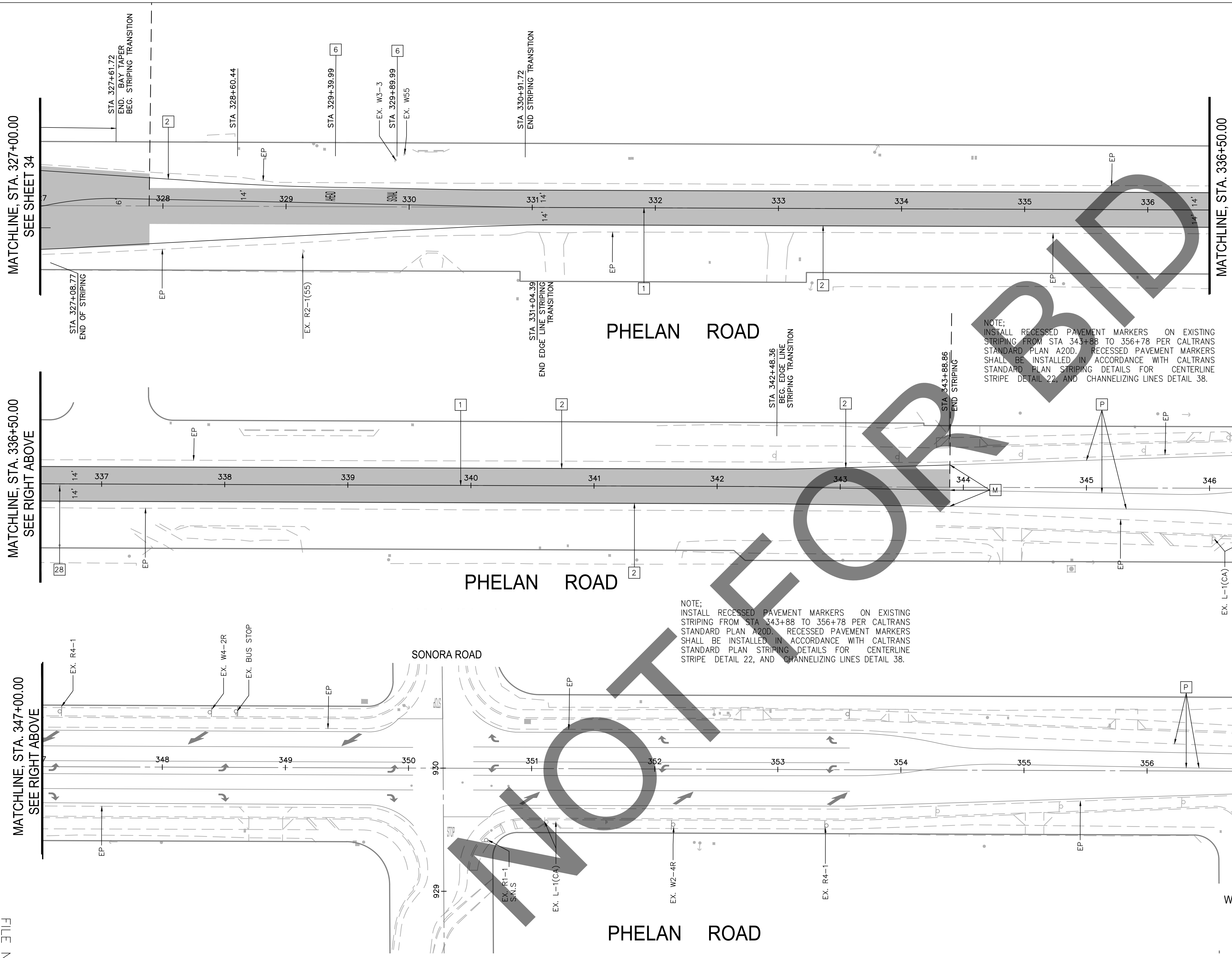

NOTE:
INSTALL RECESSED PAVEMENT MARKERS ON EXISTING STRIPING FROM STA 343+88 TO 356+78 PER CALTRANS STANDARD PLAN A20D. RECESSED PAVEMENT MARKERS SHALL BE INSTALLED IN ACCORDANCE WITH CALTRANS STANDARD PLAN STRIPING DETAILS FOR CENTERLINE STRIPE DETAIL 22, AND CHANNELIZING LINES DETAIL 38.

NOTE:
INSTALL RECESSED PAVEMENT MARKERS ON EXISTING STRIPING FROM STA 343+88 TO 356+78 PER CALTRANS STANDARD PLAN A20D. RECESSED PAVEMENT MARKERS SHALL BE INSTALLED IN ACCORDANCE WITH CALTRANS STANDARD PLAN STRIPING DETAILS FOR CENTERLINE STRIPE DETAIL 22, AND CHANNELIZING LINES DETAIL 38.

NOTE: ALL PAVEMENT MARKERS FOR INSTALLATION WITH TRAFFIC STRIPES AND FIRE HYDRANTS SHALL BE RECESSED. RECESSED PAVEMENT MARKERS SHALL BE INSTALLED IN ACCORDANCE WITH CALTRANS STANDARD PLAN A20D, AND AS SPECIFIED IN THE SPECIAL PROVISIONS.

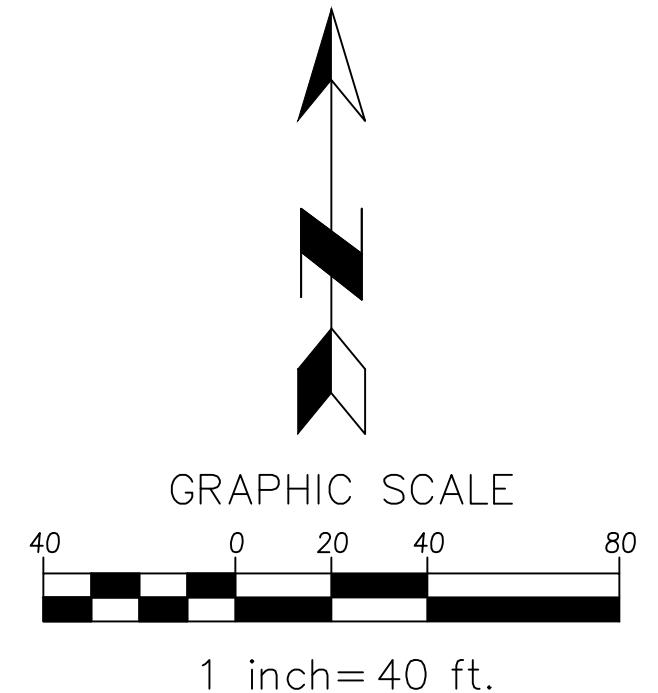

MARK	REVISIONS	DATE

Underground Service Alert
Call: TOLL FREE 1-800-227-2600
TWO WORKING DAYS BEFORE YOU DIG

FIELD CHANGES

MARK	CHANGES	RESIDENT ENGINEER	DATE
	NO CHANGES		



SAN BERNARDINO COUNTY
DEPARTMENT OF PUBLIC WORKS

DESIGNED BY: CG/JHC DRAWN BY: CG CHECKED BY: JHC/LL RECOMMENDED BY: ANTHONY PHAM, P.E.
DATE: 7/1/2024

APPROVED BY: GRANT WANN, P.E. DATE: 7/3/2024

LEI LL, P.E. SUPERVISING ENGINEER

PHELAN ROAD				
SIGNING AND STRIPING PLAN				
PHELAN AREA				
J.L. REF. J.L.#XXXX	W.O. NO. H15269	PLAN SCALE AS SHOWN	SHT. NO. 35	TOT. SHT'S. 43

MATCHLINE, STA. 357+50.00
SEE SHEET 35

MATCHLINE, STA. 367+00.00
SEE RIGHT ABOVE

MATCHLINE, STA. 377+50.00
SEE RIGHT ABOVE

MATCHLINE, STA. 367+00.00
SEE LEFT BELOW

MATCHLINE, STA. 377+50.00
SEE LEFT BELOW

MATCHLINE, STA. 388+00.00
SEE SHEET 37

PHELAN ROAD

NEVADA ROAD

BUTTEMERE ROAD

OXFORD ROAD

PHELAN ROAD

SIGNING AND STRIPING CONSTRUCTION NOTES: (THIS SHEET ONLY)

- 1 PAINT DOUBLE-YELLOW STRIPE PER CALTRANS 2018 STD. PLAN A20A, DETAIL 22.
- 2 PAINT 6-INCH SOLID WHITE EDGE LINE PER CALTRANS 2018 STD. PLAN A20B, DETAIL 27B.
- 3 PAINT 12-INCH WHITE LIMIT LINE PER CALTRANS 2018 STD. PLAN A24E.
- 5 PAINT TYPE VI LANE DROP ARROW PAVEMENT MARKING PER CALTRANS 2018 STD. PLAN A24A.
- 6 PAINT WHITE PAVEMENT MARKING LEGEND PER CALTRANS 2018 STD. PLAN A24D, (TYPE PER PLAN).
- 7 PAINT TYPE IV LEFT OR RIGHT TURN ARROW PAVEMENT MARKING PER CALTRANS 2018 STD. PLAN A24A.
- 9 PAINT 8-INCH SOLID WHITE CHANNELIZING LINE PER CALTRANS 2018 STD. PLAN A20D, DETAIL 38.
- 19 PAINT TYPE I ARROW PAVEMENT MARKING PER CALTRANS 2018 STD. PLAN A24A
- 28 INSTALL FIRE HYDRANT BLUE PAVEMENT MARKER PER CA MUTCD 2014, FIGURE 3B-102 (CA).
- 31 ALL EXISTING SIGNS TO BE PROTECTED IN PLACE UNLESS OTHERWISE SPECIFIED.
- M MATCH/JOIN EXISTING
- P PROTECT IN PLACE

NOTE:
ALL PAVEMENT MARKERS FOR INSTALLATION WITH TRAFFIC STRIPES AND FIRE HYDRANTS SHALL BE RECESSED. RECESSED PAVEMENT MARKERS SHALL BE INSTALLED IN ACCORDANCE WITH CALTRANS STANDARD PLAN A20D, AND AS SPECIFIED IN THE SPECIAL PROVISIONS.

NOTE:
INSTALL RECESSED PAVEMENT MARKERS ON EXISTING STRIPING FROM STA 383+44 TO 396+27 PER CALTRANS STANDARD PLAN A20D. RECESSED PAVEMENT MARKERS SHALL BE INSTALLED IN ACCORDANCE WITH CALTRANS STANDARD PLAN STRIPING DETAILS FOR CENTERLINE STRIPE DETAIL 22, AND CHANNELIZING LINES DETAIL 38.

Underground Service Alert

Call: TOLL FREE
1-800-227-2600

TWO WORKING DAYS BEFORE YOU DIG

MARK	CHANGES	RESIDENT ENGINEER	DATE
	NO CHANGES		
FIELD CHANGES			

REGISTERED PROFESSIONAL ENGINEER
ANTHONY PHAM
C 76378
CIVIL
STATE OF CALIFORNIA

SAN BERNARDINO COUNTY
DEPARTMENT OF PUBLIC WORKS

DESIGNED BY: CG/JHC	DRAWN BY: CG	CHECKED BY: JHC/LL	RECOMMENDED BY: ANTHONY PHAM, P.E. ENGINEERING MANAGER, TRAFFIC DIVISION
APPROVED BY: LEI LI, P.E. SUPERVISING ENGINEER	DATE: 7/2/2024	DATE: 7/3/2024	DATE: 7/1/2024

PHELAN ROAD SIGNING AND STRIPING PLAN PHELAN AREA				
J.L. REF. J.L.#XXXX	W.O. NO. H15269	PLAN SCALE AS SHOWN	SHT. NO. 36	TOT. SHT'S. 43

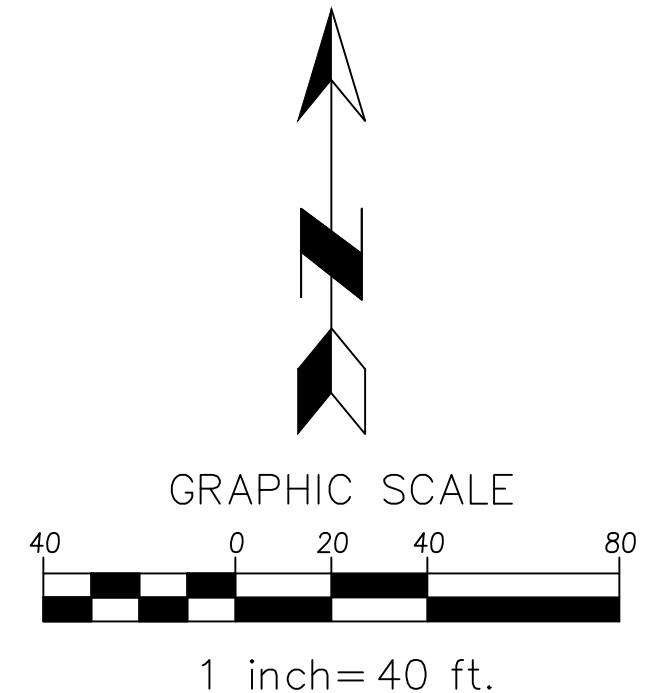

MARK	REVISIONS	APPR.	DATE

NOTE:
INSTALL RECESSED PAVEMENT MARKERS ON EXISTING STRIPING FROM STA 383+44 TO 396+27 PER CALTRANS STANDARD PLAN A20D. RECESSED PAVEMENT MARKERS SHALL BE INSTALLED IN ACCORDANCE WITH CALTRANS STANDARD PLAN STRIPING DETAILS FOR CENTERLINE STRIPE DETAIL 22, AND CHANNELIZING LINES DETAIL 38.

- SIGNING AND STRIPING CONSTRUCTION NOTES: (THIS SHEET ONLY)**
- 1 PAINT DOUBLE-YELLOW STRIPE PER CALTRANS 2018 STD. PLAN A20A, DETAIL 22.
 - 2 PAINT 6-INCH SOLID WHITE EDGE LINE PER CALTRANS 2018 STD. PLAN A20B, DETAIL 27B.
 - 3 PAINT 12-INCH WHITE LIMIT LINE PER CALTRANS 2018 STD. PLAN A24E.
 - 6 PAINT WHITE PAVEMENT MARKING LEGEND PER CALTRANS 2018 STD. PLAN A24D, (TYPE PER PLAN).
 - 7 PAINT TYPE IV LEFT OR RIGHT TURN ARROW PAVEMENT MARKING PER CALTRANS 2018 STD. PLAN A24A.
 - 9 PAINT 8-INCH SOLID WHITE CHANNELIZING LINE PER CALTRANS 2018 STD. PLAN A20D, DETAIL 38.
 - 28 INSTALL FIRE HYDRANT BLUE PAVEMENT MARKER PER CA MUTCD 2014, FIGURE 3B-102 (CA).
 - 31 ALL EXISTING SIGNS TO BE PROTECTED IN PLACE UNLESS OTHERWISE SPECIFIED.
- M MATCH/JOIN EXISTING
P PROTECT IN PLACE
- NOTE:
ALL PAVEMENT MARKERS FOR INSTALLATION WITH TRAFFIC STRIPES AND FIRE HYDRANTS SHALL BE RECESSED. RECESSED PAVEMENT MARKERS SHALL BE INSTALLED IN ACCORDANCE WITH CALTRANS STANDARD PLAN A20D, AND AS SPECIFIED IN THE SPECIAL PROVISIONS.

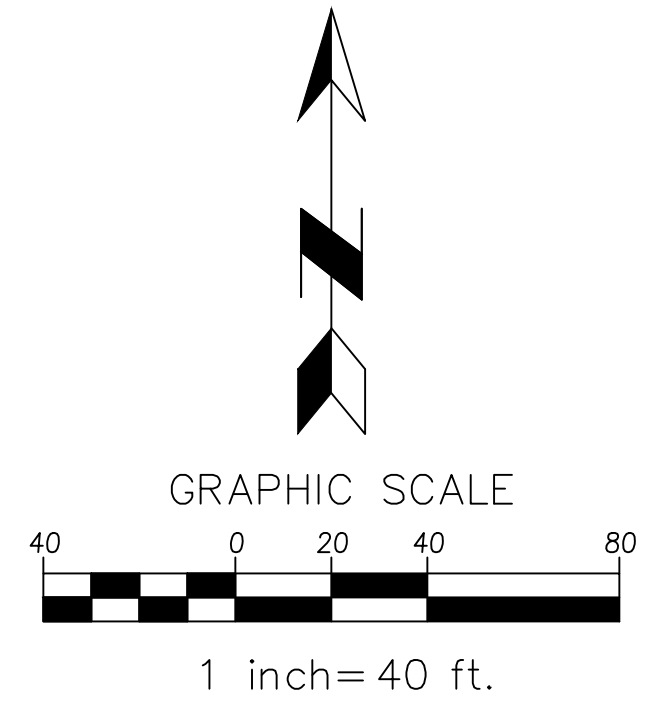
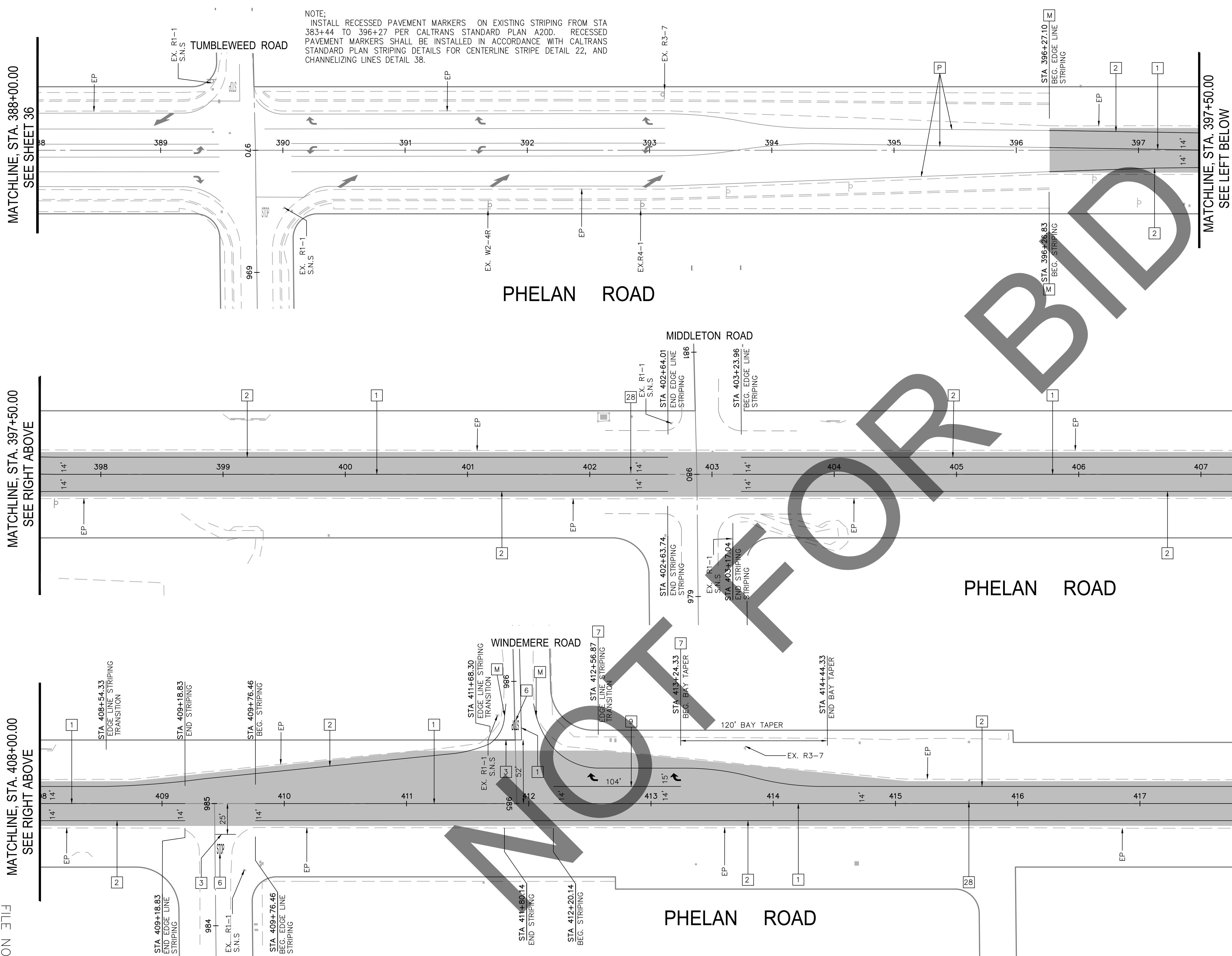

MARK	REVISIONS	DATE

Underground Service Alert
Call: TOLL FREE 1-800-227-2600
TWO WORKING DAYS BEFORE YOU DIG

MARK	CHANGES	RESIDENT ENGINEER	DATE
	NO CHANGES		

FIELD CHANGES

SAN BERNARDINO COUNTY
DEPARTMENT OF PUBLIC WORKS

DESIGNED BY: CG/JHC
DRAWN BY: CG
CHECKED BY: JHC/LL
RECOMMENDED BY: ANTHONY PHAM, P.E., ENGINEERING MANAGER, TRAFFIC DIVISION

APPROVED BY: GRANT MANN, P.E., DEPUTY DIRECTOR

DATE: 7/2/2024
DATE: 7/3/2024

J.L. REF.	W.O. NO.	PLAN SCALE	SHT. NO.	TOT. SHT'S.
J.L.#XXXX	H15269	AS SHOWN	37	43

MATCHLINE, STA. 418+50.00
SEE SHEET 37

MATCHLINE, STA. 428+00.00
SEE RIGHT ABOVE

MATCHLINE, STA. 438+50.00
SEE RIGHT ABOVE

FILE NO. 651850-013

MATCHLINE, STA. 428+00.00
SEE LEFT BELOW

MATCHLINE, STA. 438+50.00
SEE LEFT BELOW

MATCHLINE, STA. 449+00.00
SEE SHEET 39

PHELAN ROAD

PHELAN ROAD

PHELAN ROAD

CAUGHLIN ROAD

SHASTA ROAD

TERRACE VIEW RD

SIGNING AND STRIPING CONSTRUCTION NOTES: (THIS SHEET ONLY)

- 1 PAINT DOUBLE-YELLOW STRIPE PER CALTRANS 2018 STD. PLAN A20A, DETAIL 22.
- 2 PAINT 6-INCH SOLID WHITE EDGE LINE PER CALTRANS 2018 STD. PLAN A20B, DETAIL 27B.
- 3 PAINT 12-INCH WHITE LIMIT LINE PER CALTRANS 2018 STD. PLAN A24E.
- 5 PAINT TYPE VI LANE DROP ARROW PAVEMENT MARKING PER CALTRANS 2018 STD. PLAN A24A.
- 6 PAINT WHITE PAVEMENT MARKING LEGEND PER CALTRANS 2018 STD. PLAN A24D, (TYPE PER PLAN).
- 7 PAINT TYPE IV LEFT OR RIGHT TURN ARROW PAVEMENT MARKING PER CALTRANS 2018 STD. PLAN A24A.
- 9 PAINT 8-INCH SOLID WHITE CHANNELIZING LINE PER CALTRANS 2018 STD. PLAN A20D, DETAIL 38.
- 17 PAINT WHITE PAVEMENT MARKING LEGEND PER CALTRANS 2018 STD. PLAN A24C, (TYPE PER PLAN).
- 19 PAINT TYPE I ARROW PAVEMENT MARKING PER CALTRANS 2018 STD. PLAN A24A.
- 28 INSTALL FIRE HYDRANT BLUE PAVEMENT MARKER PER CA MUTCD 2014, FIGURE 3B-102 (CA).
- 31 ALL EXISTING SIGNS TO BE PROTECTED IN PLACE UNLESS OTHERWISE SPECIFIED.

[M] MATCH/JOIN EXISTING

NOTE:
ALL PAVEMENT MARKERS FOR INSTALLATION WITH TRAFFIC STRIPES AND FIRE HYDRANTS SHALL BE RECESSED. RECESSED PAVEMENT MARKERS SHALL BE INSTALLED IN ACCORDANCE WITH CALTRANS STANDARD PLAN A20D, AND AS SPECIFIED IN THE SPECIAL PROVISIONS.

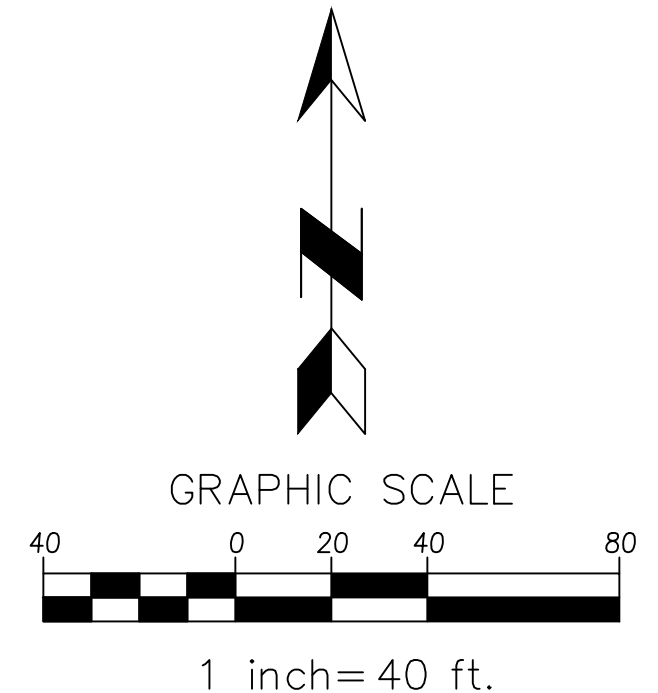

<p>Underground Service Alert Call: TOLL FREE 1-800-227-2600</p>	<p>MARK CHANGES NO CHANGES</p>		<p>RESIDENT ENGINEER DATE</p>		<p>FIELD CHANGES</p>		
			<p>DESIGNED BY: CG/JHC DRAWN BY: CG CHECKED BY: JHC/LL RECOMMENDED BY: [Signature]</p>		<p>DATE: 7/1/2024</p>		
	<p>APPROVED BY: [Signature] LEI LI, P.E. SUPERVISING ENGINEER</p>		<p>DATE: 7/2/2024</p>		<p>APPROVED BY: [Signature] GRANT MANN, P.E. DEPUTY DIRECTOR</p>		<p>DATE: 7/3/2024</p>
<p>SAN BERNARDINO COUNTY DEPARTMENT OF PUBLIC WORKS</p>				<p>PHELAN ROAD SIGNING AND STRIPING PLAN PHELAN AREA</p>			
<p>J.L. REF. J.L.#XXXX</p>		<p>W.O. NO. H15269</p>		<p>PLAN SCALE AS SHOWN</p>		<p>SHT. NO. 38 TOT. SHT'S. 43</p>	

MARK	REVISIONS	DATE

SIGNING AND STRIPING CONSTRUCTION NOTES: (THIS SHEET ONLY)

- 1 PAINT DOUBLE-YELLOW STRIPE PER CALTRANS 2018 STD. PLAN A20A, DETAIL 22.
- 2 PAINT 6-INCH SOLID WHITE EDGE LINE PER CALTRANS 2018 STD. PLAN A20B, DETAIL 27B.
- 28 INSTALL FIRE HYDRANT BLUE PAVEMENT MARKER PER CA MUTCD 2014, FIGURE 3B-102 (CA).
- 31 ALL EXISTING SIGNS TO BE PROTECTED IN PLACE UNLESS OTHERWISE SPECIFIED.
- M MATCH/JOIN EXISTING

NOTE:
ALL PAVEMENT MARKERS FOR INSTALLATION WITH TRAFFIC STRIPES AND FIRE HYDRANTS SHALL BE RECESSED.
RECESSED PAVEMENT MARKERS SHALL BE INSTALLED IN ACCORDANCE WITH CALTRANS STANDARD PLAN A20D, AND AS SPECIFIED IN THE SPECIAL PROVISIONS.

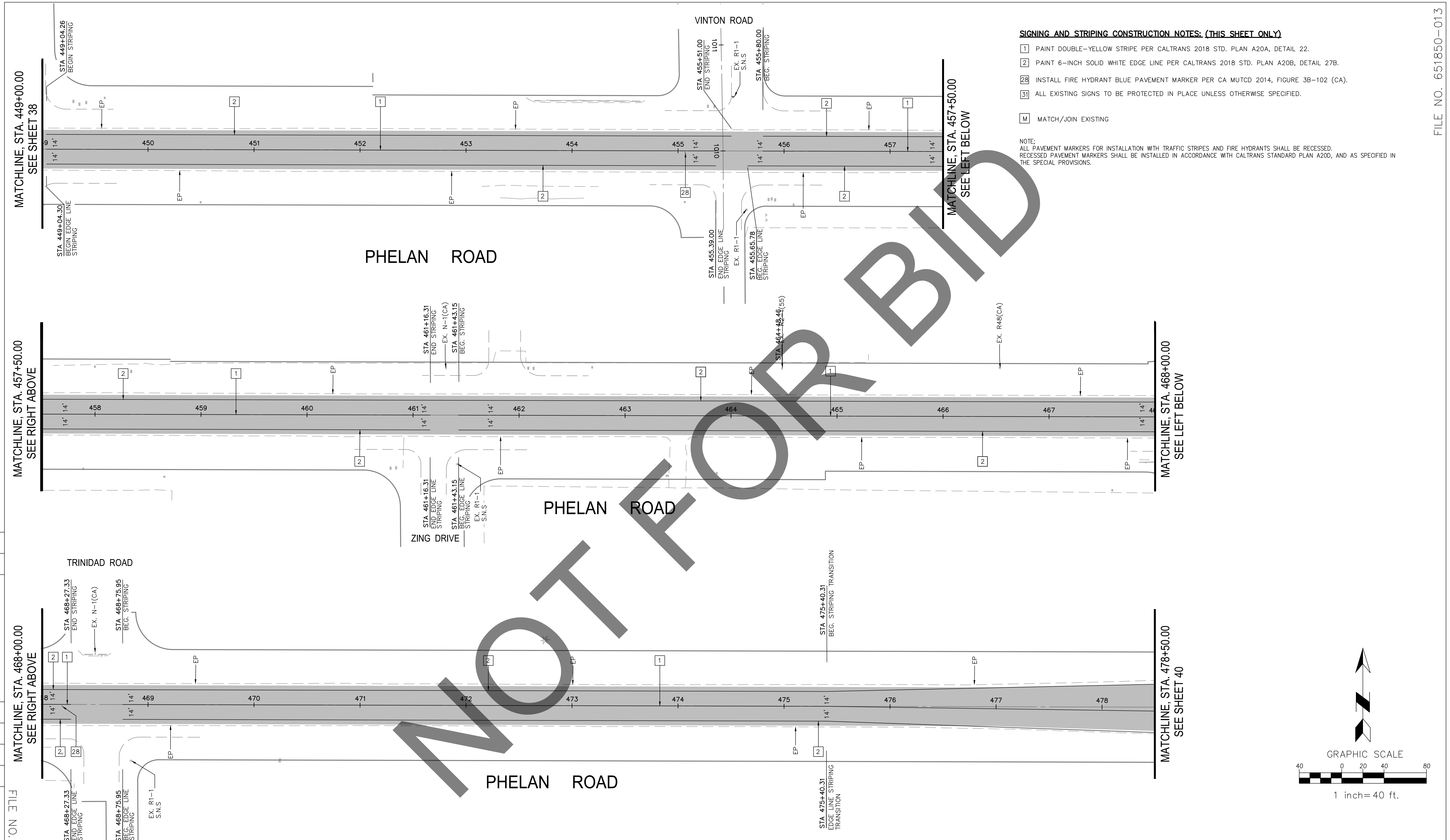

MATCHLINE, STA. 449+00.00
SEE SHEET 38

MATCHLINE, STA. 457+50.00
SEE RIGHT ABOVE

MATCHLINE, STA. 468+00.00
SEE RIGHT ABOVE

MATCHLINE, STA. 457+50.00
SEE LEFT BELOW

MATCHLINE, STA. 468+00.00
SEE LEFT BELOW

MATCHLINE, STA. 478+50.00
SEE SHEET 40

FILE NO. 651850-013

MARK	REVISIONS	DATE	APPR.

Underground Service Alert
Call: TOLL FREE 1-800-227-2600
TWO WORKING DAYS BEFORE YOU DIG

MARK	CHANGES	RESIDENT ENGINEER	DATE
	NO CHANGES		

FIELD CHANGES

SAN BERNARDINO COUNTY
DEPARTMENT OF PUBLIC WORKS

DESIGNED BY: CG/JHC	DRAWN BY: CG	CHECKED BY: JHC/LL	RECOMMENDED BY: ANTHONY PHAM, P.E. ENGINEERING MANAGER, TRAFFIC DIVISION	DATE: 7/1/2024
APPROVED BY: GRANT MANN, P.E. DEPUTY DIRECTOR	DATE: 7/2/2024	DATE: 7/3/2024	DATE: 7/3/2024	DATE: 7/3/2024

PHELAN ROAD SIGNING AND STRIPING PLAN PHELAN AREA				
J.L. REF. J.L.#XXXX	W.O. NO. H15269	PLAN SCALE AS SHOWN	SHT. NO. 39	TOT. SHT'S. 43

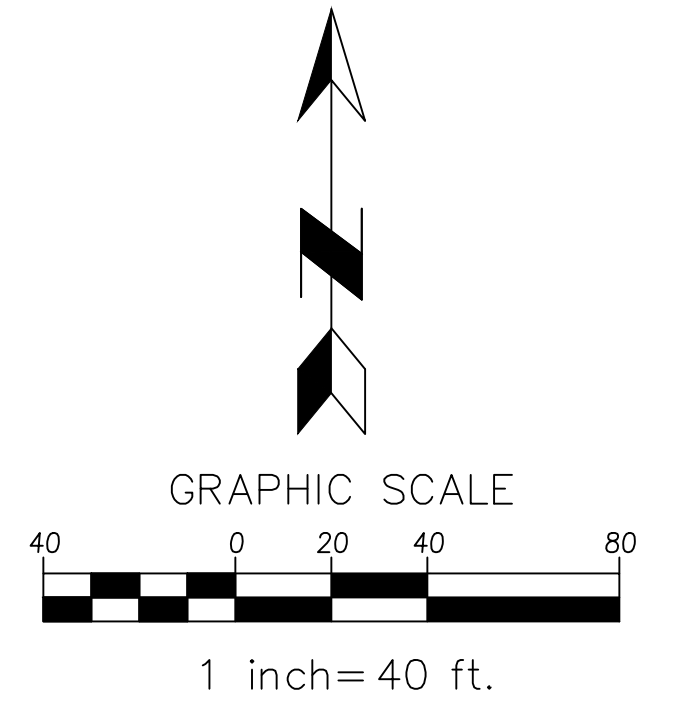

- SIGNING AND STRIPING CONSTRUCTION NOTES: (THIS SHEET ONLY)**
- 1 PAINT DOUBLE-YELLOW STRIPE PER CALTRANS 2018 STD. PLAN A20A, DETAIL 22.
 - 2 PAINT 6-INCH SOLID WHITE EDGE LINE PER CALTRANS 2018 STD. PLAN A20B, DETAIL 27B.
 - 3 PAINT 12-INCH WHITE LIMIT LINE PER CALTRANS 2018 STD. PLAN A24E.
 - 5 PAINT TYPE VI LANE DROP ARROW PAVEMENT MARKING PER CALTRANS 2018 STD. PLAN A24A.
 - 6 PAINT WHITE PAVEMENT MARKING LEGEND PER CALTRANS 2018 STD. PLAN A24D, (TYPE PER PLAN).
 - 7 PAINT TYPE IV LEFT OR RIGHT TURN ARROW PAVEMENT MARKING PER CALTRANS 2018 STD. STD. PLAN A24A.
 - 8 PAINT 6-INCH SOLID WHITE LINE.
 - 9 PAINT 8-INCH SOLID WHITE CHANNELIZING LINE PER CALTRANS 2018 STD. PLAN A20D, DETAIL 38.
 - 13 PAINT 6-INCH DOUBLE-YELLOW MEDIAN ISLAND STRIPE PER CALTRANS 2018 STD. PLAN A20B DETAIL 29.
 - 19 PAINT TYPE I ARROW PAVEMENT MARKING PER CALTRANS 2018 STD. PLAN A24A
 - 21 PAINT WHITE PAVEMENT MARKING LEGEND RAILROAD CROSSING SYMBOL PER CALTRANS 2018 STD. PLAN A24B AND MUTCD 2014, FIGURE 8B-6 (CA).
 - 22 PAINT 24-INCH SOLID WHITE LINE PER CALTRANS 2018 STD. PLAN A24B.
 - 28 INSTALL FIRE HYDRANT BLUE PAVEMENT MARKER PER CA MUTCD 2014, FIGURE 3B-102 (CA).
 - 29 PAINT 6-INCH DASHED WHITE LINE PER CALTRANS 2018 STD. PLAN A20A, DETAIL 12.
 - 30 RELOCATE AND INSTALL EXISTING W10-1 SIGN PER CA MUTCD 2014, FIGURES 2A-2(CA), 2A-3 AND 8B-6(CA).
 - 31 ALL EXISTING SIGNS TO BE PROTECTED IN PLACE UNLESS OTHERWISE SPECIFIED.
- M MATCH/JOIN EXISTING
P PROTECT IN PLACE

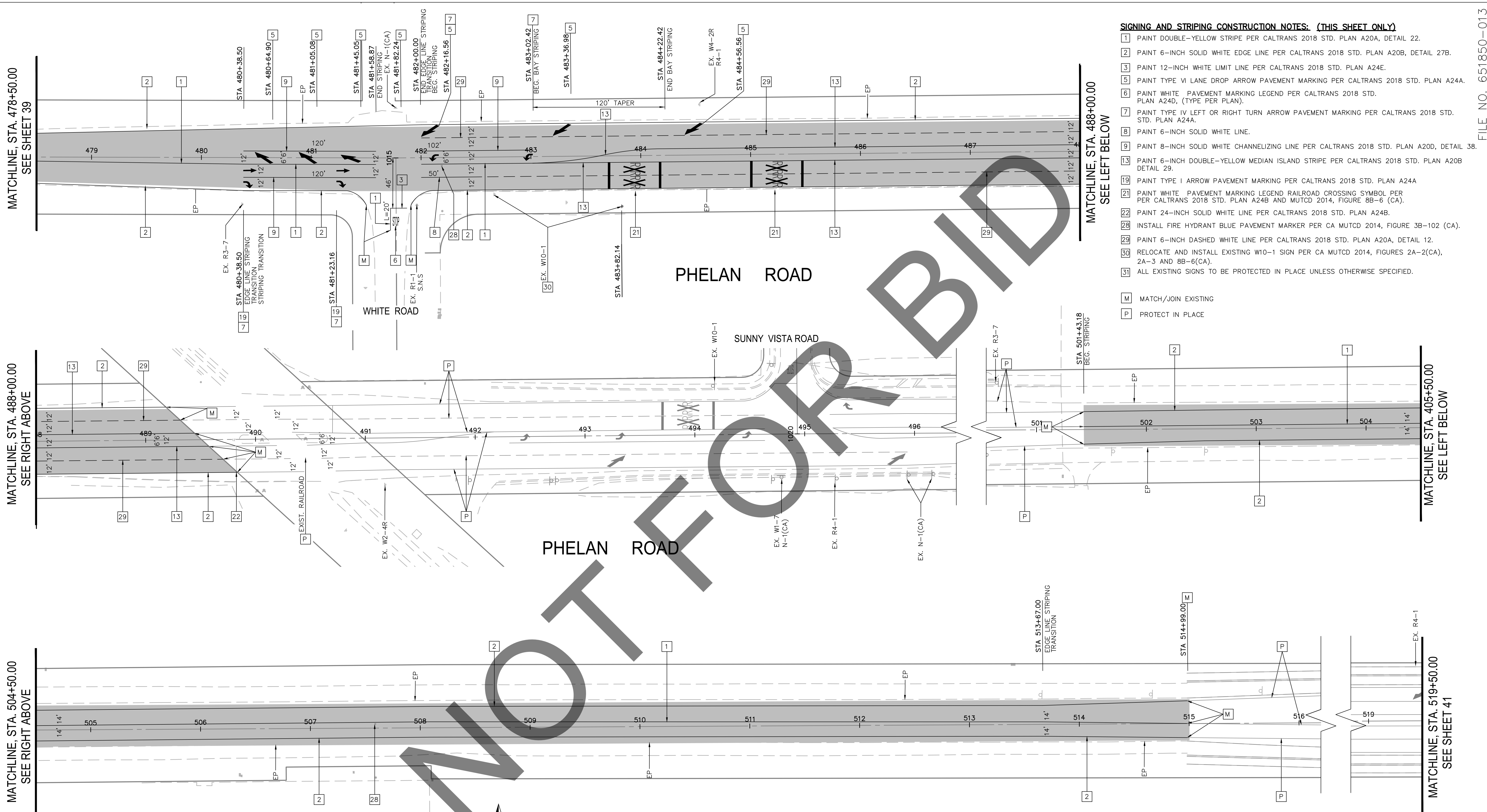

NOTE:
ALL PAVEMENT MARKERS FOR INSTALLATION WITH TRAFFIC STRIPES AND FIRE HYDRANTS SHALL BE RECESSED. RECESSED PAVEMENT MARKERS SHALL BE INSTALLED IN ACCORDANCE WITH CALTRANS STANDARD PLAN A20D, AND AS SPECIFIED IN THE SPECIAL PROVISIONS.

NOTE:
INSTALL RECESSED PAVEMENT MARKERS ON EXISTING STRIPING FROM STA 491+00 TO 501+43 PER CALTRANS STANDARD PLAN A20D. RECESSED PAVEMENT MARKERS SHALL BE INSTALLED IN ACCORDANCE WITH CALTRANS STANDARD PLAN STRIPING DETAILS FOR LANE LINES DETAIL 12, CENTERLINE STRIPE DETAIL 22, DETAIL 29, AND CHANNELIZING LINES DETAIL 38.

NOTE:
INSTALL RECESSED PAVEMENT MARKERS ON EXISTING STRIPING FROM STA 515+00 TO 528+48 PER CALTRANS STANDARD PLAN A20D. RECESSED PAVEMENT MARKERS SHALL BE INSTALLED IN ACCORDANCE WITH CALTRANS STANDARD PLAN STRIPING DETAILS FOR CENTERLINE STRIPE PER DETAIL 22, TWO WAY LEFT TURN LANE STRIPE DETAIL 32, AND CHANNELIZING LINES PER DETAIL 38.

GRAPHIC SCALE
1 inch = 40 ft.

Underground Service Alert
Call: TOLL FREE 1-800-227-2600
TWO WORKING DAYS BEFORE YOU DIG

PROFESSIONAL ENGINEER
ANTHONY PHAM
C 76378
CIVIL
STATE OF CALIFORNIA

MARK	CHANGES	RESIDENT ENGINEER	DATE
	NO CHANGES		

FIELD CHANGES

SAN BERNARDINO COUNTY
DEPARTMENT OF PUBLIC WORKS

DESIGNED BY:	DRAWN BY:	CHECKED BY:	RECOMMENDED BY:
CG/JHC	CG	JHC/LL	ANTHONY PHAM, P.E. ENGINEERING MANAGER, TRAFFIC DIVISION
DATE:	DATE:	DATE:	DATE:
7/2/2024	7/2/2024	7/3/2024	7/1/2024

APPROVED BY:
GRANT MANN, P.E.
DEPUTY DIRECTOR

PHELAN ROAD				
SIGNING AND STRIPING PLAN				
PHELAN AREA				
J.L. REF.	W.O. NO.	PLAN SCALE	SHT. NO.	TOT. SHT'S.
J.L.#XXXX	H15269	AS SHOWN	40	43

MARK	REVISIONS	APPR.	DATE

MATCHLINE, STA. 519+50.00
SEE SHEET 40

MATCHLINE, STA. 532+00.00
SEE LEFT BELOW

NOTE:
INSTALL RECESSED PAVEMENT MARKERS ON EXISTING STRIPING FROM STA 515+00 TO 528+48 PER CALTRANS STANDARD PLAN A20D. RECESSED PAVEMENT MARKERS SHALL BE INSTALLED IN ACCORDANCE WITH CALTRANS STANDARD PLAN STRIPING DETAILS FOR CENTERLINE STRIPE PER DETAIL 22, TWO WAY LEFT TURN LANE STRIPE DETAIL 32, AND CHANNELIZING LINES PER DETAIL 38.

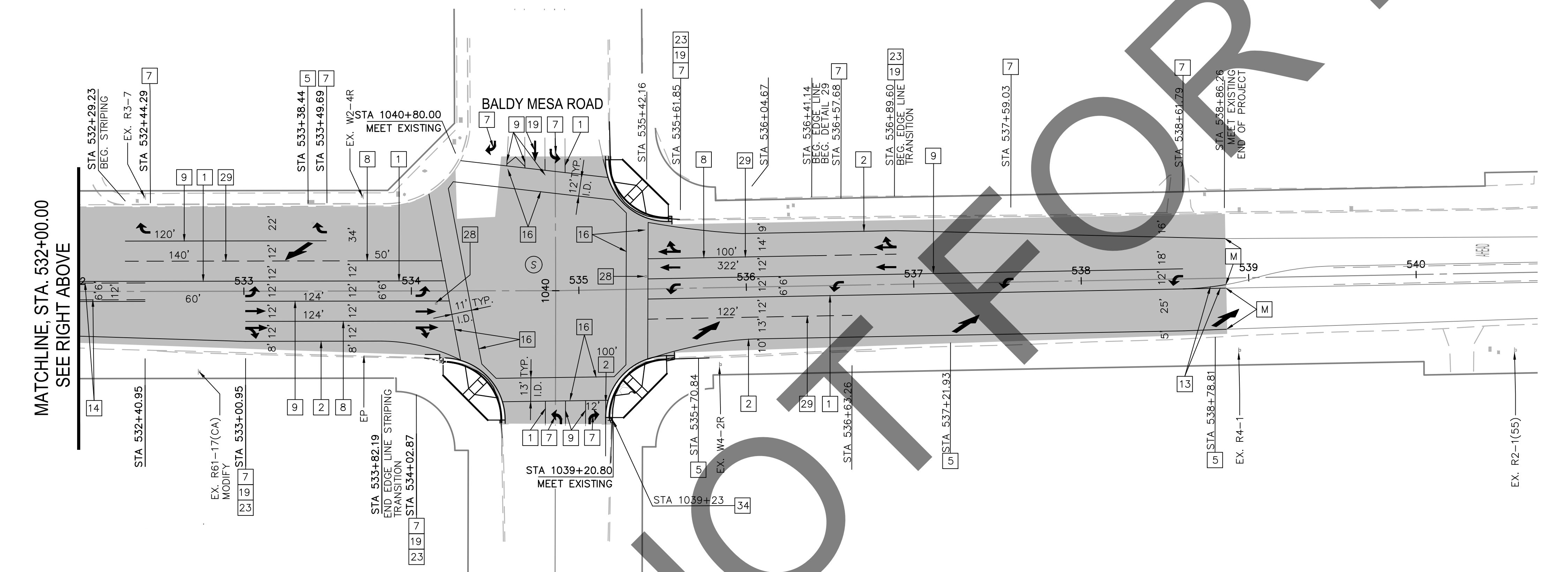
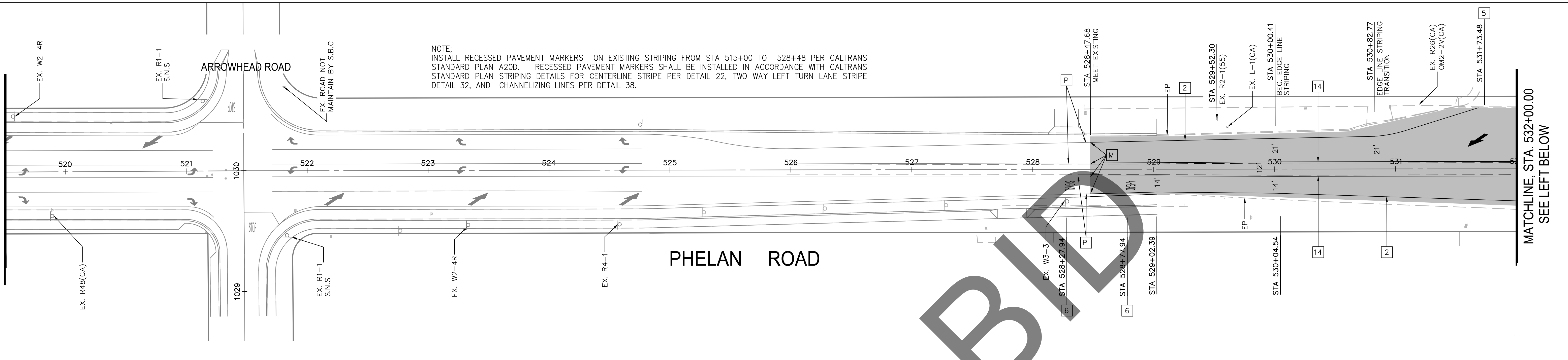

SIGNING AND STRIPING CONSTRUCTION NOTES: (THIS SHEET ONLY)

- 1 PAINT DOUBLE-YELLOW STRIPE PER CALTRANS 2018 STD. PLAN A20A, DETAIL 22.
 - 2 PAINT 6-INCH SOLID WHITE EDGE LINE PER CALTRANS 2018 STD. PLAN A20B, DETAIL 27B.
 - 5 PAINT TYPE VI LANE DROP ARROW PAVEMENT MARKING PER CALTRANS 2018 STD. PLAN A24A.
 - 6 PAINT WHITE PAVEMENT MARKING LEGEND PER CALTRANS 2018 STD. PLAN A24D, (TYPE PER PLAN).
 - 7 PAINT TYPE IV LEFT OR RIGHT TURN ARROW PAVEMENT MARKING PER CALTRANS 2018 STD. PLAN A24A.
 - 8 PAINT 6-INCH SOLID WHITE LINE.
 - 9 PAINT 8-INCH SOLID WHITE CHANNELIZING LINE PER CALTRANS 2018 STD. PLAN A20D, DETAIL 38.
 - 13 PAINT 6-INCH DOUBLE-YELLOW MEDIAN ISLAND STRIPE PER CALTRANS 2018 STD. PLAN A20B DETAIL 29.
 - 14 PAINT TWO WAY LEFT TURN LANE PER CALTRANS 2018 STD. PLAN A20B, DETAIL 32.
 - 16 PAINT 12-INCH SOLID WHITE CROSSWALK PER CALTRANS 2018 STD. PLAN A24F, BASIC AND DETAIL B OF CALTRANS A88A WHERE APPLICABLE.
 - 19 PAINT TYPE I ARROW PAVEMENT MARKING PER CALTRANS 2018 STD. PLAN A24A
 - 21 PAINT WHITE PAVEMENT MARKING LEGEND RAILROAD CROSSING SYMBOL PER CALTRANS 2018 STD. PLAN A24B AND MUTCD 2014, FIGURE 8B-6 (CA).
 - 23 PAINT TYPE VII (R) ARROW PAVEMENT MARKING PER CALTRANS 2018 STD. PLAN A24A.
 - 26 INSTALL NEW SIGN(S) AS SHOWN ON PLAN AND PER CA MUTCD 2014, FIGURES 2A-2(CA) AND 2A-3.
 - 29 PAINT 6-INCH DASHED WHITE LINE PER CALTRANS 2018 STD. PLAN A20A, DETAIL 12.
 - 34 INSTALL TYPE L-1(CA)OM2-2V OBJECT MARKER PER THE CA MUTCD 2014, FIG 2C-13(CA).
- P PROTECT IN PLACE
M MATCH/JOIN EXISTING
S SIGNALIZED INTERSECTION

NOTE:
ALL PAVEMENT MARKERS FOR INSTALLATION WITH TRAFFIC STRIPES AND FIRE HYDRANTS SHALL BE RECESSED. RECESSED PAVEMENT MARKERS SHALL BE INSTALLED IN ACCORDANCE WITH CALTRANS STANDARD PLAN A20D, AND AS SPECIFIED IN THE SPECIAL PROVISIONS.

MARK	REVISIONS	APPR.	DATE

MARK	REVISIONS	APPR.	DATE

FILE NO. 651850-013

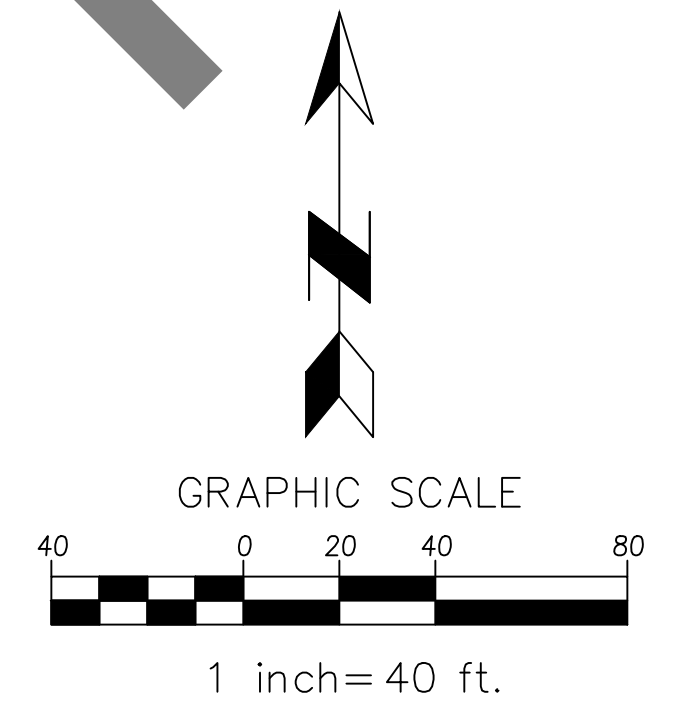

Underground Service Alert

Call: TOLL FREE 1-800-227-2600

TWO WORKING DAYS BEFORE YOU DIG

MARK	CHANGES	RESIDENT ENGINEER	DATE
	NO CHANGES		

FIELD CHANGES

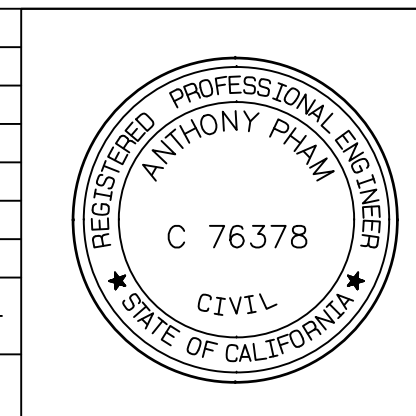

SAN BERNARDINO COUNTY
DEPARTMENT OF PUBLIC WORKS

DESIGNED BY: CG/JHC
DRAWN BY: CG
CHECKED BY: JHC/LL
RECOMMENDED BY: ANTHONY PHAM, P.E.
DATE: 7/1/2024

APPROVED BY: GRANT MANN, P.E.
DATE: 7/3/2024

J.L. REF.	W.O. NO.	PLAN SCALE	SHT. NO.	TOT. SHT'S.
J.L.#XXXX	H15269	AS SHOWN	41	43

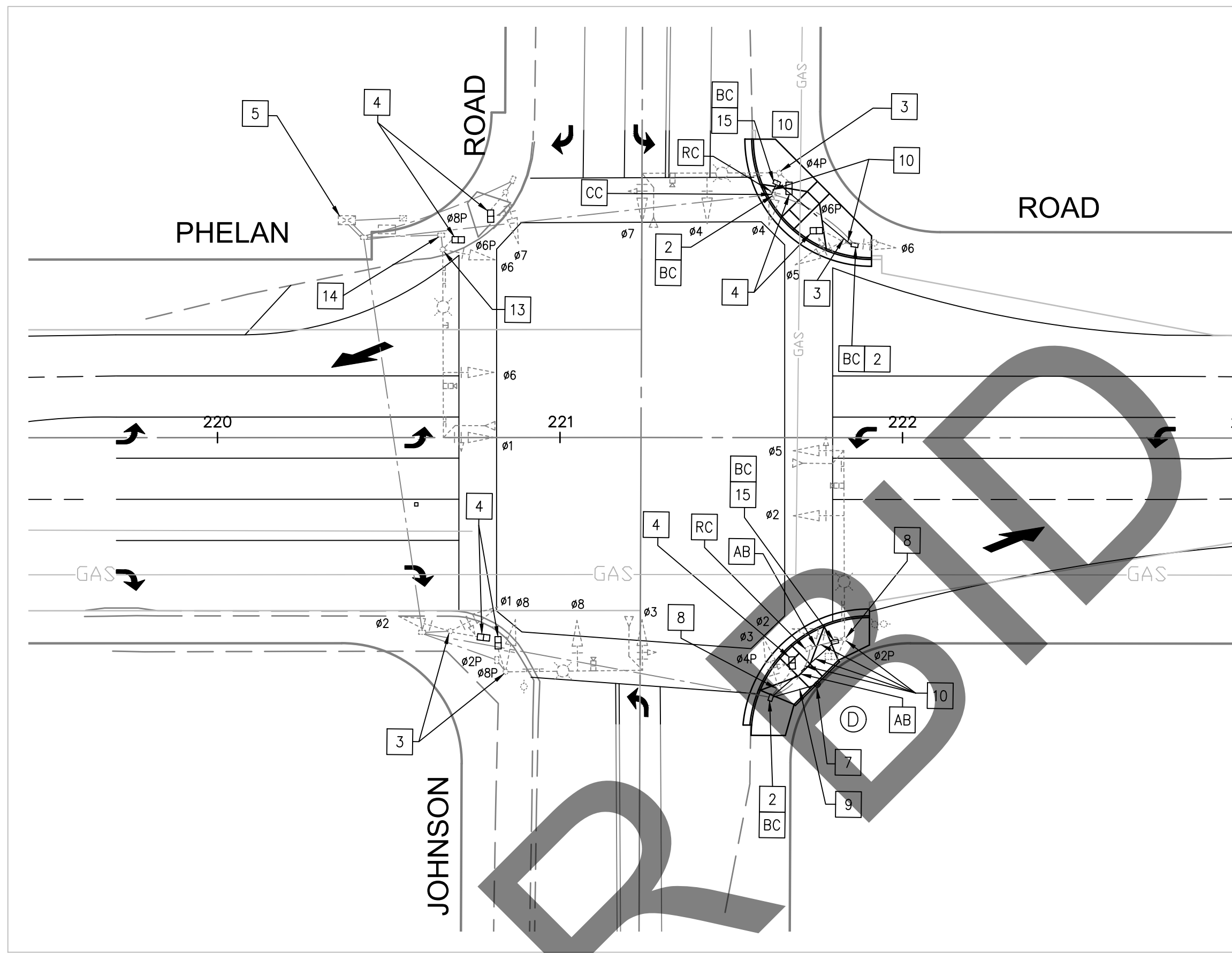
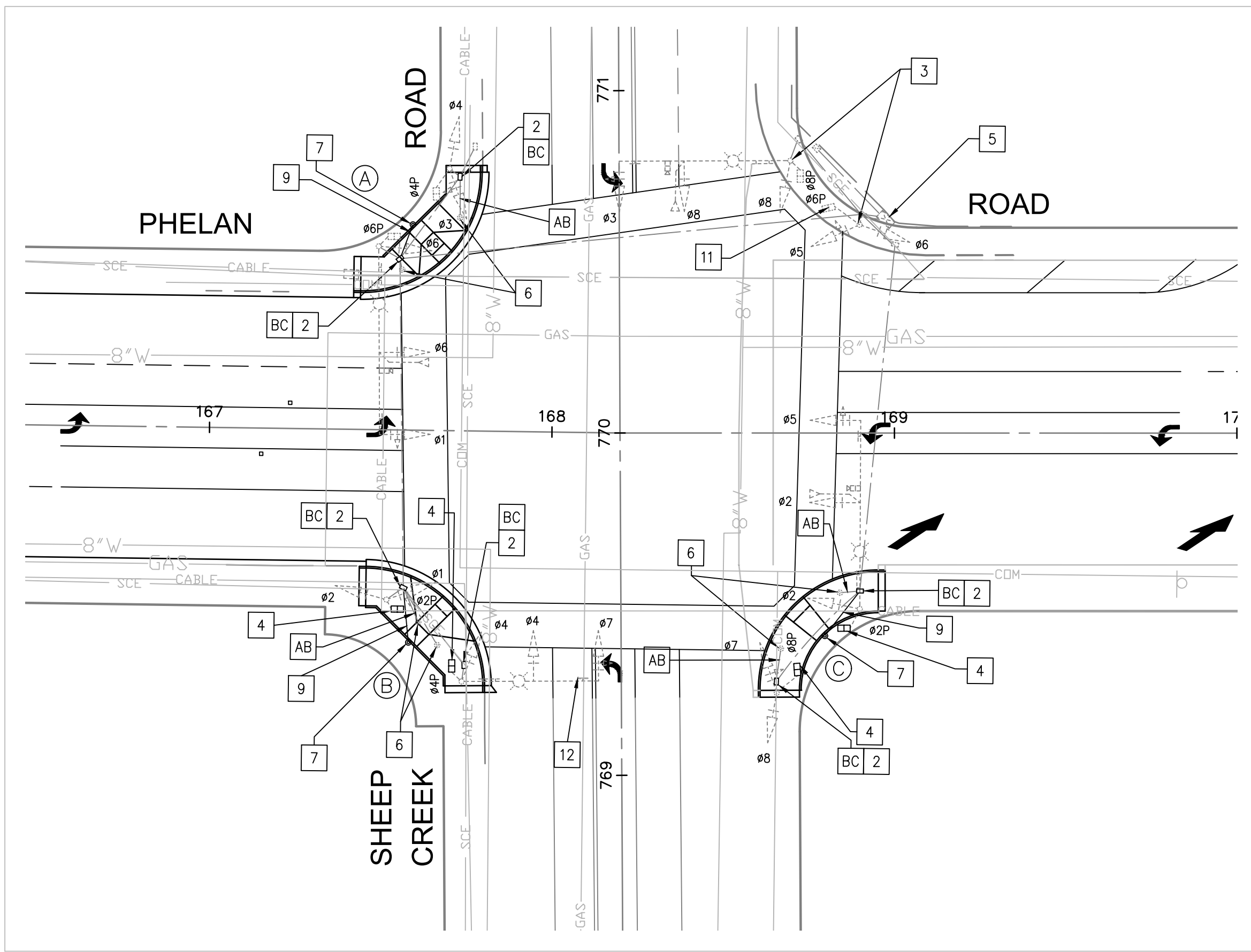

CONSTRUCTION NOTES (THIS SHEET)

- 1 - REMOVE AND SALVAGE EXISTING PEDESTRIAN POST (PPBP) AND PUSH BUTTON ASSEMBLY. REMOVE FOUNDATION. FURNISH AND INSTALL NEW PPBP AT THE SAME LOCATION ON NEW FOUNDATION, WITH ACCESSIBLE PEDESTRIAN PEDESTRIAN PUSH BUTTON STATION (APPBS) PER CALTRANS STANDARD PLANS 2022, ES-5C AND ES-7A. FURNISH AND INSTALL SIGNAL CABLE AS REQUIRED BY APPBS MANUFACTURER FROM EACH APPBS TO THE CONTROLLER ASSEMBLY, REMOVE EXISTING 3CSC TO THE CONTROLLER ASSEMBLY.
- 2 - REMOVE EXISTING PULL BOX. FURNISH AND REPLACE PULL BOX WITH NEW #6 PULL BOX AT SAME LOCATION AND ADJUST TO FINISH SURFACE.
- 3 - REMOVE AND SALVAGE EXISTING PEDESTRIAN PUSH BUTTON ASSEMBLY (PBA). FURNISH AND INSTALL APPBS PER CALTRANS STANDARD PLANS 2022, ES-5, FURNISH AND INSTALL SIGNAL CABLE AS REQUIRED BY APPBS MANUFACTURER FROM EACH APPBS TO THE CONTROLLER ASSEMBLY, REMOVE EXISTING 3CSC TO THE CONTROLLER ASSEMBLY.
- 4 - FURNISH AND REPLACE NON-COUNTDOWN PEDESTRIAN SIGNAL HEAD WITH LED COUNTDOWN PEDESTRIAN SIGNAL HEAD ON EXISTING MOUNTING, PER CALTRANS STANDARD PLAN 2022, ES-4B.
- 5 - FURNISH AND INSTALL ACCESSIBLE PEDESTRIAN SIGNAL SYSTEM (APS) SHELF MOUNT CONTROL UNIT IN CABINET WITH ALL NECESSARY WIRES AND CONNECTORS PER MANUFACTURER'S SPECIFICATIONS, TO ACHIEVE INTENDED OPERATION.
- 6 - REMOVE AND SALVAGE EXISTING PEDESTRIAN PUSH BUTTON POST (PPBP) COMPLETE. REMOVE FOUNDATION. REMOVE EXISTING 3CSC CABLE TO THE CONTROLLER CABINET.
- 7 - FURNISH AND INSTALL NEW PPBP INDICATED ON PLAN ON NEW FOUNDATION, WITH (2) APPBS PER CALTRANS STANDARD PLANS 2022, ES-5C AND ES-7A, FURNISH AND INSTALL ANY NECESSARY BRACKETS OR HARDWARE FOR 90 DEGREE INSTALLATION OF DUAL APPBS ON SINGLE POST. APPBS SHALL BE INSTALLED ON CROSSWALK SIDE OF STANDARD.
- 8 - REMOVE AND SALVAGE EXISTING PBA. PLATE HOLE TO A SMOOTH FINISH, REMOVE EXISTING 3CSC CABLE TO THE CONTROLLER CABINET.
- 9 - FURNISH AND INSTALL 1.5-INCH CONDUIT FROM NEW PPBP TO PULL BOX INDICATED ON PLAN, WITH APPBS, PER CALTRANS STANDARD PLANS 2022, ES-5C AND ES-7A, FURNISH AND INSTALL SIGNAL CABLE AS REQUIRED BY APPBS MANUFACTURER FROM EACH APPBS TO THE CONTROLLER ASSEMBLY.
- 10 - FURNISH AND INSTALL 3-INCH CONDUIT FROM EXISTING PULL BOX TO NEW PULL BOX INDICATED ON PLAN. DISCONNECT EXISTING CABLES FROM SIGNAL POLE TERMINAL COMPARTMENT AND PULL-OUT AND REMOVE SIGNAL CABLES FROM EXISTING CONDUIT. PULL-IN AND REUSE EXISTING CABLES THROUGH NEW AND EXISTING CONDUITS INDICATED ON PLAN. RE-CONNECT CABLES IN EXISTING SIGNAL POLE TERMINAL COMPARTMENT FOR INTENDED OPERATION. CONTRACTOR TO VERIFY AND LOCATE PULL BOXES IN THE FIELD.
- 11 - FURNISH AND REPLACE LED COUNTDOWN PEDESTRIAN SIGNAL FACE MODULE IN EXISTING PEDESTRIAN HEAD, PER CALTRANS STANDARD PLAN 2022, ES-4B, DETAIL B.
- 12 - FURNISH AND REPLACE R73-3 (CA) SIGN ON MAST ARM INDICATED ON PLAN.
- 13 - FURNISH AND INSTALL HANDHOLE COVER ON EXISTING SIGNAL POLE INDICATED ON PLAN.
- 14 - FURNISH AND REPLACE PULL BOX LID INDICATED ON PLAN.
- 15 - INTERCEPT EXISTING CONDUIT AND FURNISH AND INSTALL #6 PULL BOX INDICATED ON PLAN.

SAN BERNARDINO COUNTY - TRAFFIC SIGNAL GENERAL NOTES:

1. ALL PEDESTRIAN SIGNAL INDICATIONS SHALL BE INSTALLED WITH "LED" PEDESTRIAN MODULES. PEDESTRIAN MODULES SHALL BE EQUIPPED WITH COUNTDOWN TIMERS PER THE CALTRANS 2022 STANDARD PLAN ES-4B DETAIL B.
2. SIGNAL POLE LOCATIONS ARE APPROXIMATE.
3. ALL BACK PLATES SHALL BE LOUVERED.
4. ALL BACK PLATES AND VISORS SHALL BE METAL, NO PLASTIC PARTS WILL BE ALLOWED.
5. ALL PULL BOXES SHALL BE NUMBER 6 UNLESS OTHERWISE NOTED. THE TOP OF THE PULL BOXES SHALL BE FLUSH WITH FINISHED GRADE AS SHOWN ON THE CALTRANS 2022 STANDARD PLAN ES-8A.
6. PULL BOXES SHALL BE INSTALLED PER THE CALTRANS 2022 STANDARD PLAN ES-8A AND SHALL NOT BE INSTALLED IN OR WITHIN A CURB ACCESS RAMP.
7. PULL BOXES LOCATED IN ROADWAYS OR SHOULDER AREAS SUBJECT TO TRAFFIC, SHALL BE TRAFFIC TYPE PER THE CALTRANS 2022 STANDARD PLAN ES-8B.
8. COUPLING NUTS SHALL BE USED FOR ALL TYPE (1-A) POLES PER THE CALTRANS 2022 STANDARD PLAN ES-7B.
9. PEDESTRIAN PUSH BUTTON SHALL BE ACCESSIBLE PEDESTRIAN SYSTEM TYPE WITH PLACARD R10-3 SIZE 9"x12" AND PER THE CALTRANS 2018 STANDARD PLANS ES-7A AND RSP ES-5C.
10. ALL UNUSED TENONS SHALL BE CAPPED.
11. ALL WIRING AND CABLES SHALL BE NEW UNLESS OTHERWISE NOTED.
12. ALL NEW CONDUIT SHALL BE MINIMUM 4-INCH SCHEDULE 80 ELECTRICAL GRADE PVC AT A MINIMUM 36-INCH DEPTH INCLUDING A 12-INCH SAND ZONE COVERING.
13. LOCATION OF ALL UNDERGROUND FACILITIES ARE APPROXIMATE. THE CONTRACTOR SHALL POHOLE TO DETERMINE THE EXACT LOCATIONS AND VERIFY ALL CONDITIONS ON THE JOB SITE. HAND DIG FOUNDATIONS UNTIL CLEAR OF ANY OBSTRUCTIONS. PHONE THE UNDERGROUND SERVICE ALERT AT (800) 227-2600, TWO WORKING DAYS BEFORE DIGGING.
14. THE CONTRACTOR SHALL NOTIFY THE COUNTY REPRESENTATIVE TO SCHEDULE A FIELD REVIEW WITH TRAFFIC DIVISION TO VERIFY THE LOCATION OF SIGNAL POLES, CONTROLLER CABINET, AND SERVICE CABINET.

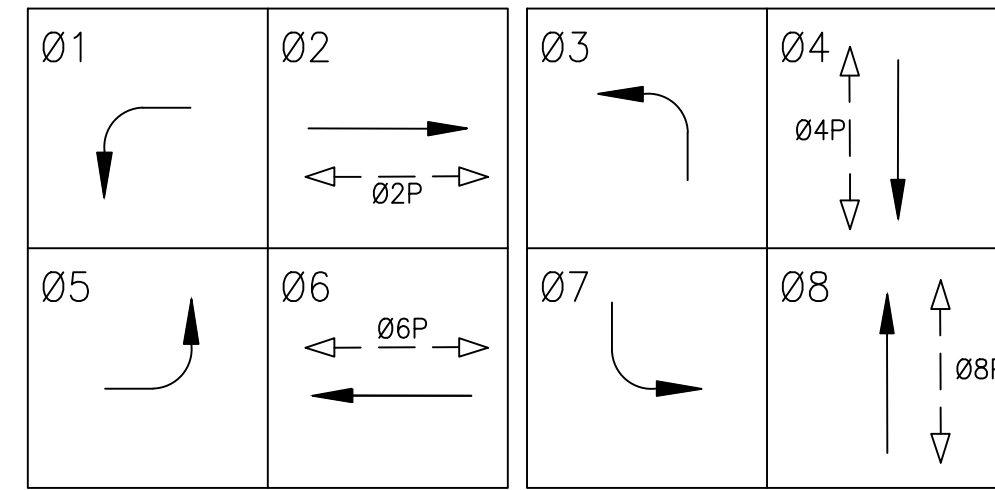

PHASE DIAGRAM FOR SHEEP CREEK

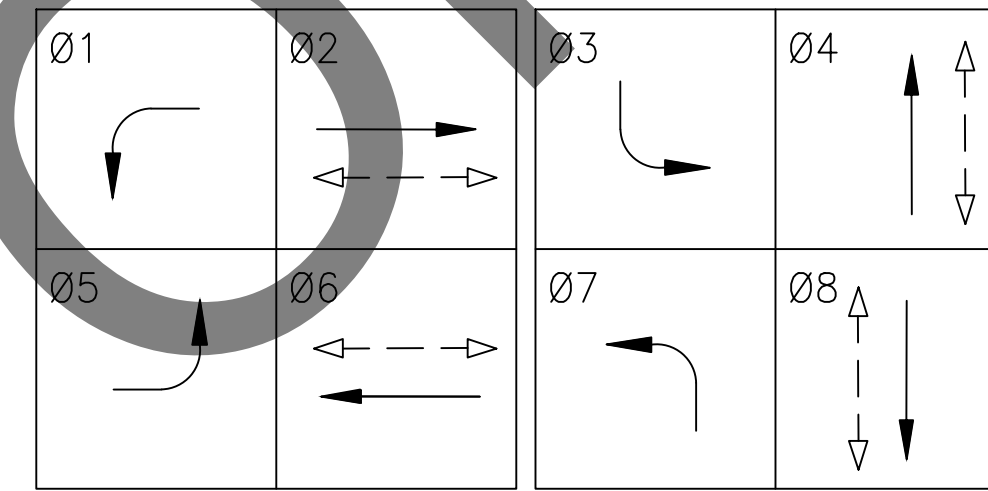

PHASE DIAGRAM FOR JOHNSON ROAD

POLE AND EQUIPMENT SCHEDULE						
POLE NO.	STANDARD		POLE LOCATION		PEDESTRIAN PUSH BUTTON	
	TYPE	'HEIGHT	"A"	"B"	QUADRANT	ARROW
A	PEDESTRIAN PUSH BUTTON POST (NEW)	5'-7"	15.00'	13.8'	SOUTH	→
					EAST	←
B	PEDESTRIAN PUSH BUTTON POST (NEW)	5'-7"	12.54'	16.5'	NORTH	←
					EAST	→
C	PEDESTRIAN PUSH BUTTON POST (NEW)	5'-7"	15.5'	12.85'	NORTH	→
					WEST	←

NOTE:
INSTALL (5'-7") POST OR AS NEEDED TO ACCOMMODATE PROPER AAPBS MOUNTING HEIGHT. ANY EXCESS POLE HEIGHT ABOVE AAPBS SHALL BE CUT OFF AND CAPPED AS DIRECTED BY THE ENGINEER

POLE AND EQUIPMENT SCHEDULE						
POLE NO.	STANDARD		POLE LOCATION		PEDESTRIAN PUSH BUTTON	
	TYPE	'HEIGHT	"A"	"B"	QUADRANT	ARROW
D	PEDESTRIAN PUSH BUTTON POST (NEW)	5'-7"	15.00'	13.68'	WEST	←
				NORTH	→	

NOTE:
INSTALL (5'-7") POST OR AS NEEDED TO ACCOMMODATE PROPER AAPBS MOUNTING HEIGHT. ANY EXCESS POLE HEIGHT ABOVE AAPBS SHALL BE CUT OFF AND CAPPED AS DIRECTED BY THE ENGINEER

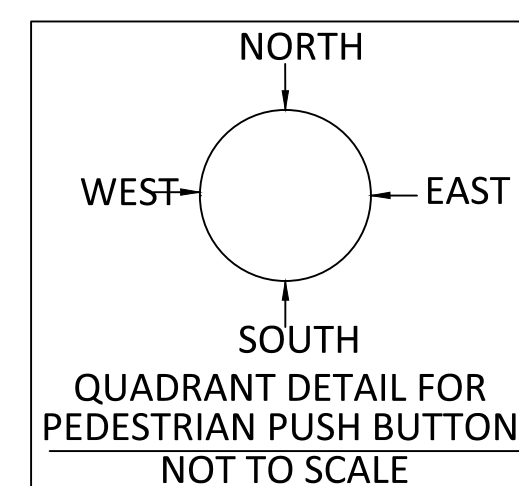
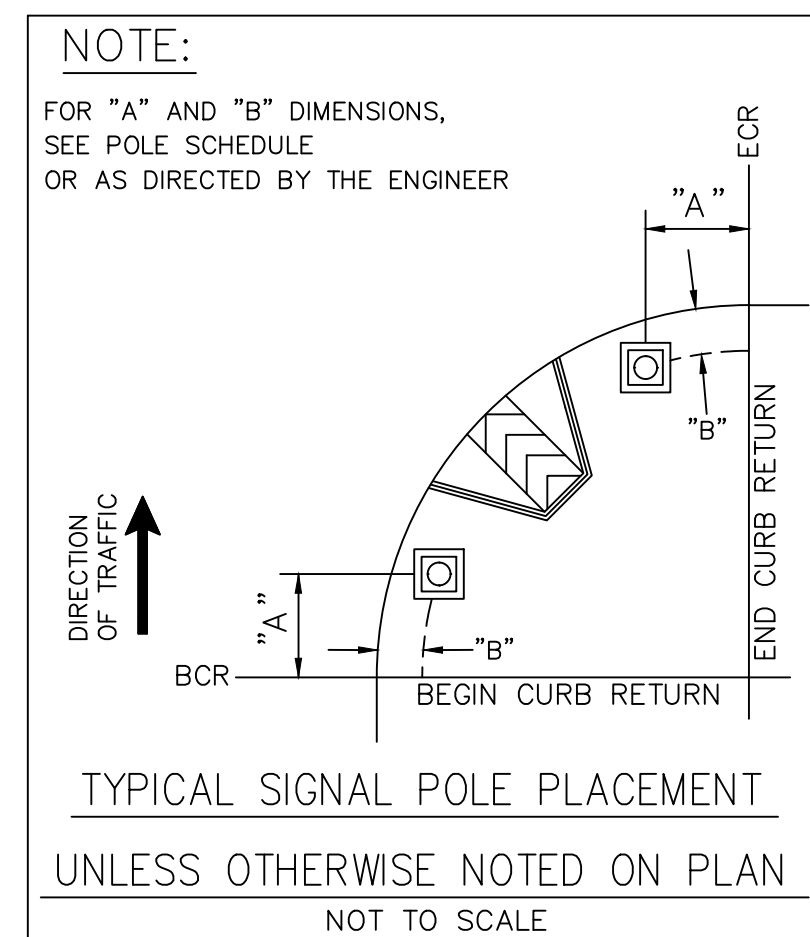

STANDARD NOTES

- AB - ABANDON. IF APPLIED TO CONDUIT, REMOVE CONDUCTORS.
- BC - INSTALL PULL BOX IN EXISTING CONDUIT RUN.
- CB - INSTALL CONDUIT INTO EXISTING PULL BOX.
- RC - EQUIPMENT OR MATERIAL TO BE REMOVED AND BECOME PROPERTY OF THE CONTRACTOR.
- RL - RELOCATE EQUIPMENT.
- RS - REMOVE AND SALVAGE EQUIPMENT.
- CC - CONNECT NEW CONDUIT TO EXISTING CONDUIT

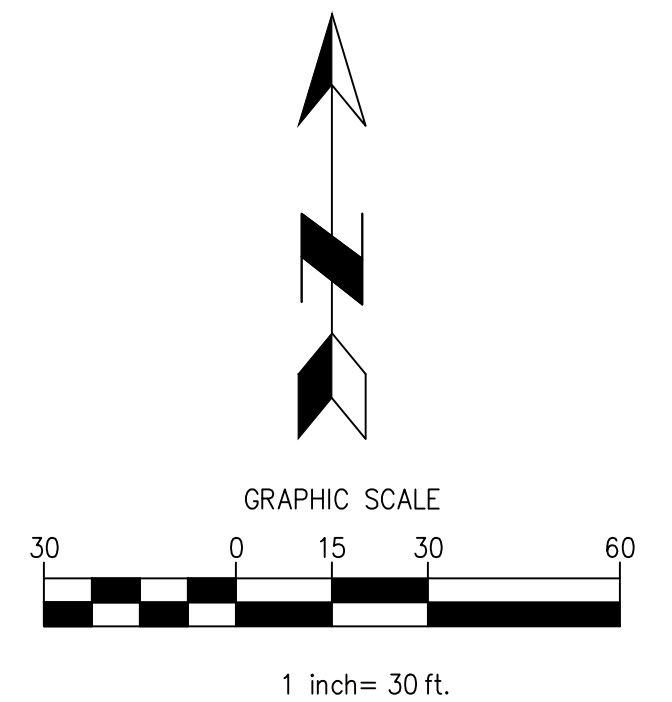

Underground Service Alert
Call: TOLL FREE 1-800-227-2600
TWO WORKING DAYS BEFORE YOU DIG

MARK	CHANGES	RESIDENT ENGINEER	DATE
	NO CHANGES		

FIELD CHANGES

REGISTERED PROFESSIONAL ENGINEER
ANTHONY PHAM
C 76378
CIVIL
STATE OF CALIFORNIA

SAN BERNARDINO COUNTY
DEPARTMENT OF PUBLIC WORKS

DESIGNED BY: IH | DRAWN BY: IH | CHECKED BY: JHC | RECOMMENDED BY: [Signature] | DATE: 7/1/2024

APPROVED BY: [Signature] | DATE: 7/3/2024
LEI LI, P.E. SUPERVISING ENGINEER | GRANT MANN, P.E. DEPUTY DIRECTOR

PHELAN ROAD SIGNAL IMPROVEMENTS PLAN				
PHELAN AREA				
J.L. REF.	W.O. NO.	PLAN SCALE	SHT. NO.	TOT. SHTS.
J.L.#XXXX	H15269	AS SHOWN	42	43

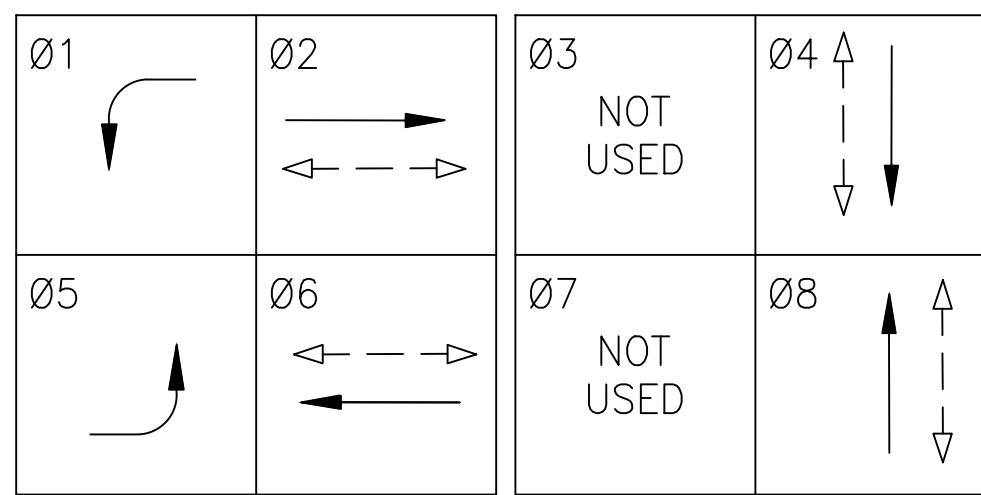
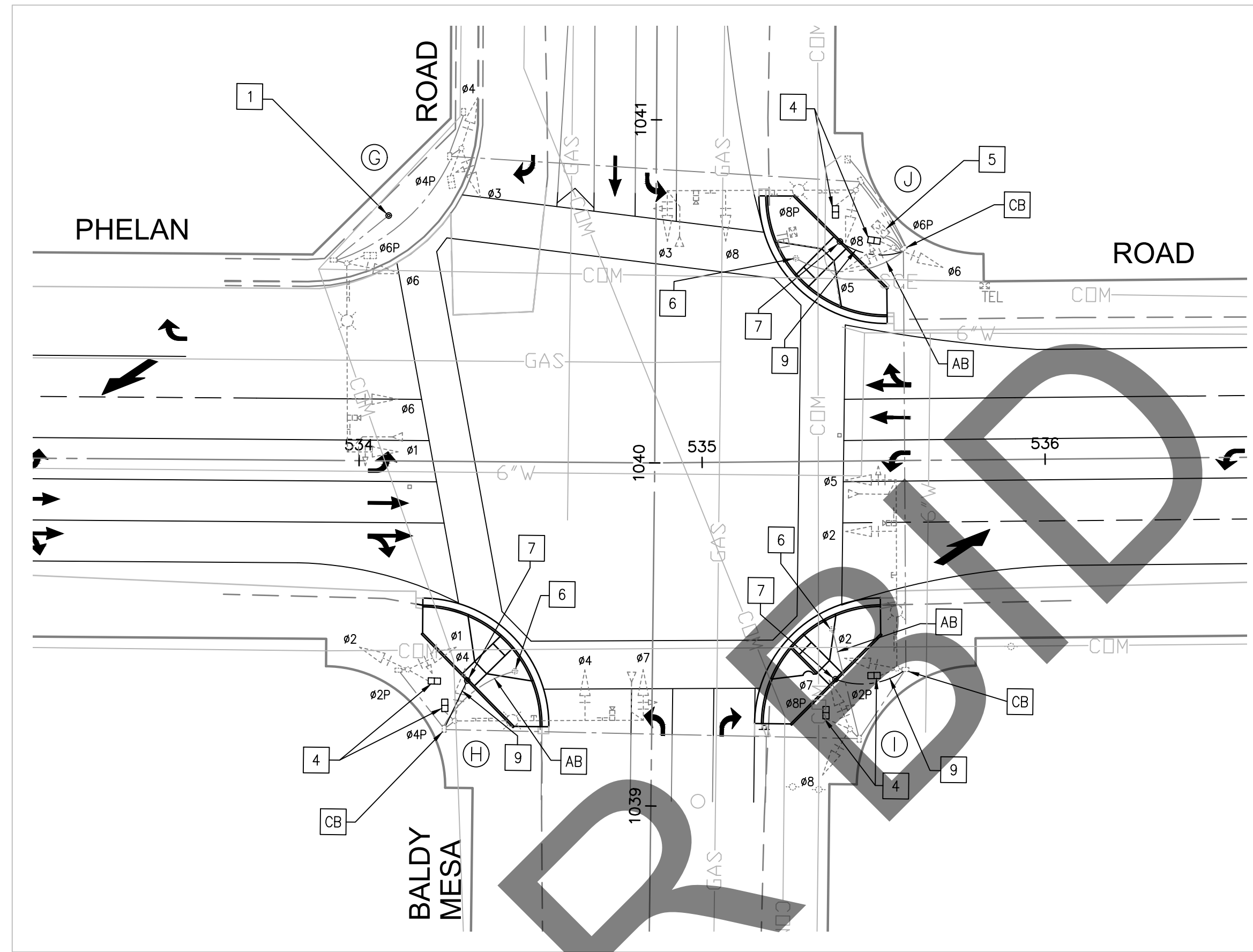
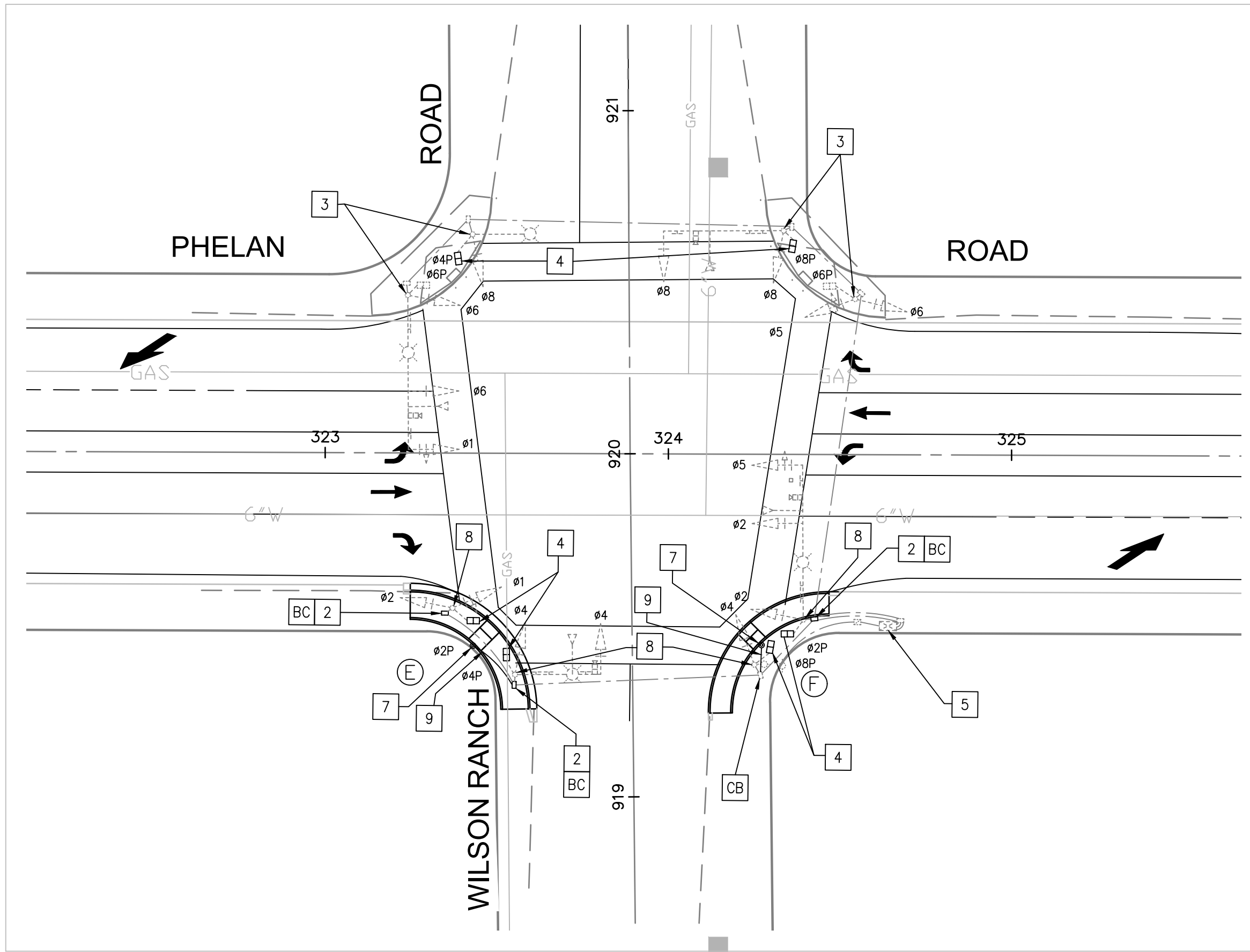

PHASE DIAGRAM FOR WILSON RANCH

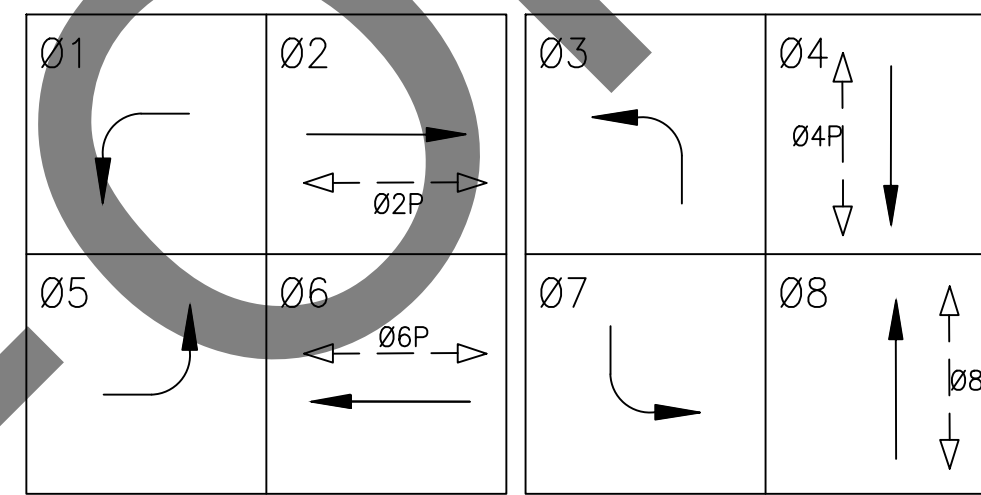

PHASE DIAGRAM FOR BALDY MESA

POLE AND EQUIPMENT SCHEDULE							
POLE NO.	STANDARD		POLE LOCATION		PEDESTRIAN PUSH BUTTON		
	TYPE	HEIGHT	"A"	"B"	QUADRANT	ARROW	PHASE
E	PEDESTRIAN PUSH BUTTON POST (NEW)	5'-7"	18.2'	8.7'	NORTH	←	Ø2P
					EAST	→	Ø4P
F	PEDESTRIAN PUSH BUTTON POST (NEW)	5'-7"	19.5'	7.48'	NORTH	→	Ø2P
				WEST	←	Ø8P	

¹NOTE: INSTALL (5'-7") POST OR AS NEEDED TO ACCOMMODATE PROPER AAPBS MOUNTING HEIGHT. ANY EXCESS POLE HEIGHT ABOVE AAPBS SHALL BE CUT OFF AND CAPPED AS DIRECTED BY THE ENGINEER

POLE AND EQUIPMENT SCHEDULE							
POLE NO.	STANDARD		POLE LOCATION		PEDESTRIAN PUSH BUTTON		
	TYPE	HEIGHT	"A"	"B"	QUADRANT	ARROW	PHASE
G	PEDESTRIAN PUSH BUTTON POST (NEW)	5'-7"	21.1'	12.8'	SOUTH	→	Ø6P
				EAST	←	Ø4P	
H	PEDESTRIAN PUSH BUTTON POST (NEW)	5'-7"	12.8'	18.8'	NORTH	←	Ø2P
				EAST	→	Ø4P	
I	PEDESTRIAN PUSH BUTTON POST (NEW)	5'-7"	12.6'	16.1'	NORTH	→	Ø2P
				WEST	←	Ø8P	
J	PEDESTRIAN PUSH BUTTON POST (NEW)	5'-7"	13.2'	16.2'	SOUTH	←	Ø6P
				WEST	→	Ø8P	

¹NOTE: INSTALL (5'-7") POST OR AS NEEDED TO ACCOMMODATE PROPER AAPBS MOUNTING HEIGHT. ANY EXCESS POLE HEIGHT ABOVE AAPBS SHALL BE CUT OFF AND CAPPED AS DIRECTED BY THE ENGINEER

CONSTRUCTION NOTES (THIS SHEET)

- REMOVE AND SALVAGE EXISTING PEDESTRIAN POST (PPBP) AND PUSH BUTTON ASSEMBLY. REMOVE FOUNDATION. FURNISH AND INSTALL NEW PPBP AT THE SAME LOCATION ON NEW FOUNDATION, WITH ACCESSIBLE PEDESTRIAN PEDESTRIAN PUSH BUTTON STATION (APPBS) PER CALTRANS STANDARD PLANS 2022, ES-5C AND ES-7A. FURNISH AND INSTALL SIGNAL CABLE AS REQUIRED BY APPBS MANUFACTURER FROM EACH APPBS TO THE CONTROLLER ASSEMBLY, REMOVE EXISTING 3CSC TO THE CONTROLLER ASSEMBLY.
- REMOVE EXISTING PULL BOX. FURNISH AND REPLACE PULL BOX WITH NEW #6 PULL BOX AT SAME LOCATION AND ADJUST TO FINISH SURFACE.
- REMOVE AND SALVAGE EXISTING PEDESTRIAN PUSH BUTTON ASSEMBLY (PBA). FURNISH AND INSTALL APPBS PER CALTRANS STANDARD PLANS 2022, ES-5. FURNISH AND INSTALL SIGNAL CABLE AS REQUIRED BY APPBS MANUFACTURER FROM EACH APPBS TO THE CONTROLLER ASSEMBLY, REMOVE EXISTING 3CSC TO THE CONTROLLER ASSEMBLY.
- FURNISH AND REPLACE NON-COUNTDOWN PEDESTRIAN SIGNAL HEAD WITH LED COUNTDOWN PEDESTRIAN SIGNAL HEAD ON EXISTING MOUNTING, PER CALTRANS STANDARD PLAN 2022, ES-4B.
- FURNISH AND INSTALL ACCESSIBLE PEDESTRIAN SIGNAL SYSTEM (APS) SHELF MOUNT CONTROL UNIT IN CABINET WITH ALL NECESSARY WIRES AND CONNECTORS PER MANUFACTURER'S SPECIFICATIONS, TO ACHIEVE INTENDED OPERATION.
- REMOVE AND SALVAGE EXISTING PEDESTRIAN PUSH BUTTON POST (PPBP) COMPLETE. REMOVE FOUNDATION. REMOVE EXISTING 3CSC CABLE TO THE CONTROLLER CABINET.
- FURNISH AND INSTALL NEW PPBP INDICATED ON PLAN ON NEW FOUNDATION, WITH (2) APPBS PER CALTRANS STANDARD PLANS 2022, ES-5C AND ES-7A. FURNISH AND INSTALL ANY NECESSARY BRACKETS OR HARDWARE FOR 90 DEGREE INSTALLATION OF DUAL APPBS ON SINGLE POST. APPBS SHALL BE INSTALLED ON CROSSWALK SIDE OF STANDARD.
- REMOVE AND SALVAGE EXISTING PBA. PLATE HOLE TO A SMOOTH FINISH, REMOVE EXISTING 3CSC CABLE TO THE CONTROLLER CABINET.
- FURNISH AND INSTALL 1.5-INCH CONDUIT FROM NEW PPBP TO PULL BOX INDICATED ON PLAN, WITH APPBS, PER CALTRANS STANDARD PLANS 2022, ES-5C AND ES-7A. FURNISH AND INSTALL SIGNAL CABLE AS REQUIRED BY APPBS MANUFACTURER FROM EACH APPBS TO THE CONTROLLER ASSEMBLY.
- FURNISH AND INSTALL 3-INCH CONDUIT FROM EXISTING PULL BOX TO NEW PULL BOX INDICATED ON PLAN. DISCONNECT EXISTING CABLES FROM SIGNAL POLE TERMINAL COMPARTMENT AND PULL-OUT AND REMOVE SIGNAL CABLES FROM EXISTING CONDUIT. PULL-IN AND REUSE EXISTING CABLES THROUGH NEW AND EXISTING CONDUITS INDICATED ON PLAN. RE-CONNECT CABLES IN EXISTING SIGNAL POLE TERMINAL COMPARTMENT FOR INTENDED OPERATION. CONTRACTOR TO VERIFY AND LOCATE PULL BOXES IN THE FIELD.
- FURNISH AND REPLACE LED COUNTDOWN PEDESTRIAN SIGNAL FACE MODULE IN EXISTING PEDESTRIAN HEAD, PER CALTRANS STANDARD PLAN 2022, ES-4B, DETAIL B.
- FURNISH AND REPLACE R73-3 (CA) SIGN ON MAST ARM INDICATED ON PLAN.
- FURNISH AND INSTALL HANDHOLE COVER ON EXISTING SIGNAL POLE INDICATED ON PLAN.
- FURNISH AND REPLACE PULL BOX LID INDICATED ON PLAN.
- INTERCEPT EXISTING CONDUIT AND FURNISH AND INSTALL #6 PULL BOX INDICATED ON PLAN.

STANDARD NOTES

- AB - ABANDON. IF APPLIED TO CONDUIT, REMOVE CONDUCTORS.
- BC - INSTALL PULL BOX IN EXISTING CONDUIT RUN.
- CB - INSTALL CONDUIT INTO EXISTING PULL BOX.
- CC - EQUIPMENT OR MATERIAL TO BE REMOVED AND BECOME PROPERTY OF THE CONTRACTOR.
- RL - RELOCATE EQUIPMENT.
- RS - REMOVE AND SALVAGE EQUIPMENT.
- CC - CONNECT NEW CONDUIT TO EXISTING CONDUIT

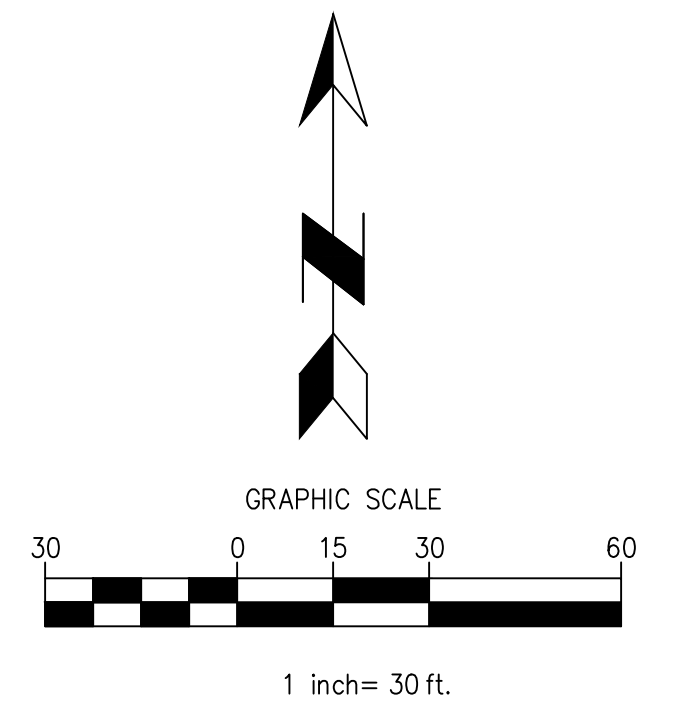

Call: TOLL FREE 1-800-227-2600

MARK	CHANGES	RESIDENT ENGINEER	DATE

FIELD CHANGES



SAN BERNARDINO COUNTY DEPARTMENT OF PUBLIC WORKS

DESIGNED BY:	DRAWN BY:	CHECKED BY:	RECOMMENDED BY:	DATE
IH	IH	JHC	<i>[Signature]</i>	7/1/2024
APPROVED BY:				DATE
<i>[Signature]</i>				7/3/2024
LEI LI, P.E. SUPERVISING ENGINEER				GRANT MANN, P.E. DEPUTY DIRECTOR

PHELAN ROAD SIGNAL IMPROVEMENTS PLAN

PHELAN AREA

J.L. REF. J.L.#XXXX	W.O. NO. H15269	PLAN SCALE AS SHOWN	SHT. NO. 43	TOT. SHT'S. 43
---------------------	-----------------	---------------------	-------------	----------------