







PEC 1- Krikorian (168sf)

Final Audit Report

2023-04-25

Created:	2023-04-25
By:	Tracye Sinclair (Tracye.Sinclair@res.sbcounty.gov)
Status:	Signed
Transaction ID:	CBJCHBCAABAABeXbQQIRv7Lz0iqjwbSRT7tIHC4oKdzQ

"PEC 1- Krikorian (168sf)" History

-  Document created by Tracye Sinclair (Tracye.Sinclair@res.sbcounty.gov)
2023-04-25 - 8:13:54 PM GMT
-  Document emailed to rgkrikorian@gmail.com for signature
2023-04-25 - 8:14:10 PM GMT
-  Email viewed by rgkrikorian@gmail.com
2023-04-25 - 8:15:20 PM GMT
-  Signer rgkrikorian@gmail.com entered name at signing as Raffy Krikorian
2023-04-25 - 8:16:13 PM GMT
-  Document e-signed by Raffy Krikorian (rgkrikorian@gmail.com)
Signature Date: 2023-04-25 - 8:16:15 PM GMT - Time Source: server
-  Agreement completed.
2023-04-25 - 8:16:15 PM GMT

NOT FOR BID

EXHIBIT "A"

Ptn. Lots 14 and 15, Block "M" of Valley of Enchantment
Park Map Book 23, Page 77

LOT 13

LOT 14 & 15
APN 0343-192-22

SCALE: 1"=10'

LINE DATA:

	DIRECTION	DISTANCE
L1	S88°34'31"W	4.65'
L2	N02°02'00"E	21.88'
L3	N89°49'57"E	7.79'
L4	S01°20'11"E	14.80'
L5	S31°28'31"W	8.18'

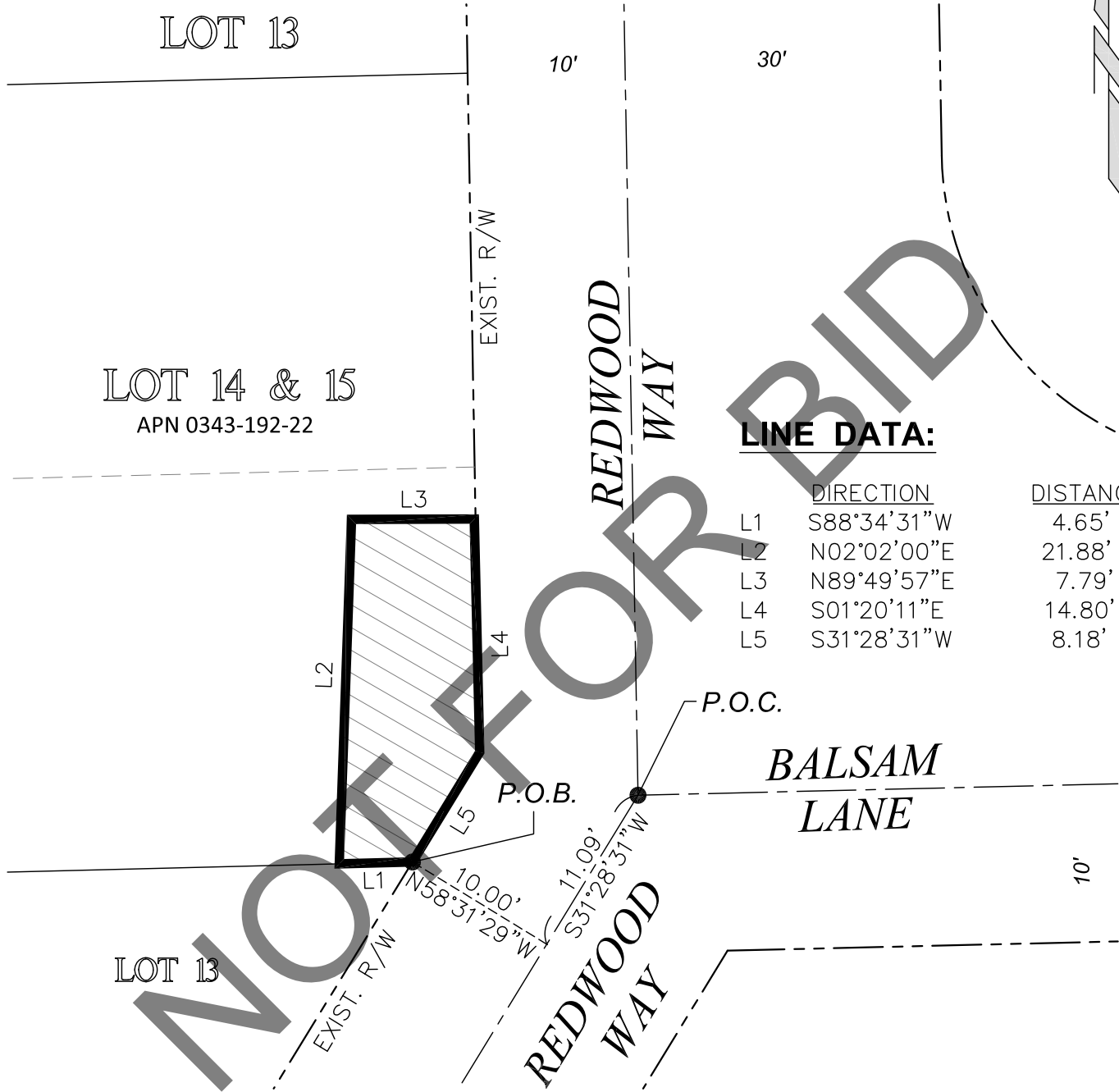

NOTES:
THIS MAP HAS BEEN COMPILED FROM RECORD DATA AND OTHER AVAILABLE MATERIALS AND DOES NOT REPRESENT A FIELD SURVEY.

P.O.C. = POINT OF COMMENCEMENT
P.O.B. = POINT OF BEGINNING
R/W = RIGHT OF WAY

 AREA OF PERMIT TO ENTER AND CONSTRUCT: 168± sq. ft.

San Bernardino County
 Department of Public Works - Transportation
Right - of - Way Plat
REDWOOD ROAD
 AT
BALSAM LANE
 CRESTLINE AREA

W.O. No.	Parcel No.	Owner
H15156	PEC-2	KRIKORIAN, RAFFY

UNINCORPORATED AREA

ROAD NAME : Redwood Way
W.O. No. : H15156
PARCEL No. : PEC-3
A.P.N. : 0343-192-32 (ptr)

PERMIT TO ENTER AND CONSTRUCT

Marybelle Nelson, Trustee of the Marybelle Nelson Revocable Trust

Dated July 23, 2021,

Hereby consent(s) to permit SAN BERNARDINO COUNTY, a body corporate and politic of the State of California, its officers, agents and employees and persons under contract with said County and their employees, the privilege and right to enter upon or across the property shown on the map attached hereto and made a part hereof, for construction purposes:

The purpose of this Permit to Enter and Construct is for:

Remove and Replace Guardrails and other miscellaneous appurtenances thereto at discretion of San Bernardino County

This Permit to Enter and Construct will expire upon completion of the construction project known as "Remove and Replace Guardrails – Crestline Area".

 7/16/24
Date

Marybelle Nelson, Trustee of the
Marybelle Nelson Revocable
Trust dated July 23, 2021

Date

*Standard and Special Drawings
(Green Pages)*

inserted here

NOT FOR BIDD

LIST OF STANDARD AND SPECIAL DRAWINGS (GREEN PAGES)

NOTICE TO RESIDENTS (English/Spanish)

SAN BERNARDINO COUNTY STANDARDS

303A

303B

CALTRANS STANDARD PLANS DATED 2018

A3A

A3B

A3C

RSP A20B

A73C

RSP A73B

RSP A77L2

A77M1

A77N2

RSP A77N4

A77N5

A77N5A

A77N6

RSP A77P1

A77R4

RSP A77S1

RSP A85

A85A

A86

A85B

A87B

T3A

T3B

T9

T10

T13

D87D

CA MUTCD DATED 2014

FIGURE 2A-2 (CA)

SECTION 2C.65

FIGURE 2C-13 (CA)

SECTION 3B.23

NOT FOR BID



NOTICE TO THE RESIDENTS OF CRESTLINE ROAD

San Bernardino County Department of Public Works has contracted with (Company name) for the (type of work) of (name of road) in the (city) area. The construction shall include (detailed description of work).

This work will be performed between the dates of (start date) and (end date).

Normal working hours will be between the hours of _____ A.M. and _____ P.M. Monday through Friday.

There will be "No Parking Signs" posted on your street indicating the specific dates work will be performed on the street. During the time we are working, access to the public will be limited and we ask the following:

1. Do not park your vehicles on the roadway
2. Do not allow water to run on the roadway
3. Do not allow children to play in the roadway
4. Do not place trash cans or other debris on the roadway

We regret any inconvenience that this work may cause you and we thank you for your cooperation in assisting us in rebuilding your street.

Thank you.

(Company name)

(Company contact name)

(Company phone number)

If you need further assistance, contact the Department of Public Works at (909) 387-7920.



NOTIFICACIÓN A LOS RESIDENTES DE CRESTLINE ROAD

San Bernardino County Department of Public Works, a contratado con (Company name) para (type of work) la calle llamada (name of road) en la ciudad de (city). La construcción va a incluir (detailed description of work).

Este trabajo será hecho entre la fecha de (start date) y (end date). Las horas elegidas para hacer este trabajo serán entre las _____ de la mañana y _____ de la tarde de lunes a viernes.

Habrà letreros indicando que "No Habrà Estacionamiento" en la calle y especificando el horario cuando el trabajo será hecho. Durante el tiempo que estaremos trabajando en la calle, la entrada para el público será limitada y por esta razón pedimos lo siguiente:

1. No estacionen sus vehículos en la calle.
2. No permita que corra el agua hacia la calle.
3. No permita que los niños jueguen en la calle.
4. No ponga los botes de basura o cualquier otra basura en la calle.

Lamentamos la inconveniencia que causara este trabajo y les agradecemos por su cooperación y asistencia en el mejoramiento de su calle.

Muchas Gracias.

(Company name)

(Company contact name)

(Company phone number)

Si necesita asistencia favor de hablar al Public Works, (909) 387-7920.

**SAN BERNARDINO COUNTY
STANDARDS**

NOT FOR BID

R/W = RIGHT OF WAY
 MAX = MAXIMUM
 MIN = MINIMUM



PLAN

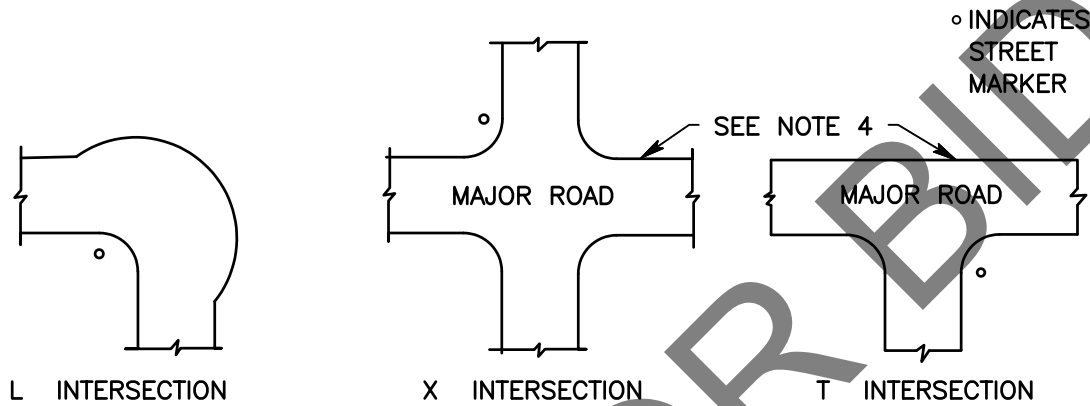

TYPICAL LOCATION

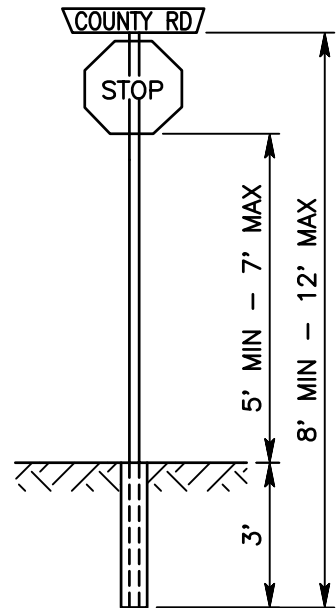

ELEVATION

NOTES:

1. MARKER TO BE SET ON COUNTY RIGHT OF WAY.
2. LOCATION OF MARKER SHOWN IS APPROXIMATE.
3. MARKERS TO BE VISIBLE FOR A DISTANCE OF 150 FEET.
4. IF EITHER ROAD IS DIVIDED INTO 4 LANES OR MORE (MAJOR ROAD), ADDITIONAL MARKERS WILL BE REQUIRED.
5. STREET MARKERS LOCATED AT MAJOR ROADS WILL BE MOUNTED ON 12 FOOT POSTS TO ACCOMMODATE A STOP SIGN.



SAN BERNARDINO COUNTY DEPARTMENT OF PUBLIC WORKS

**STREET MARKER
 (TYPICAL LOCATION)**

BRENDON P. BIGGS, PE
 DIRECTOR OF PUBLIC
 WORKS/ROAD
 COMMISSIONER

303A

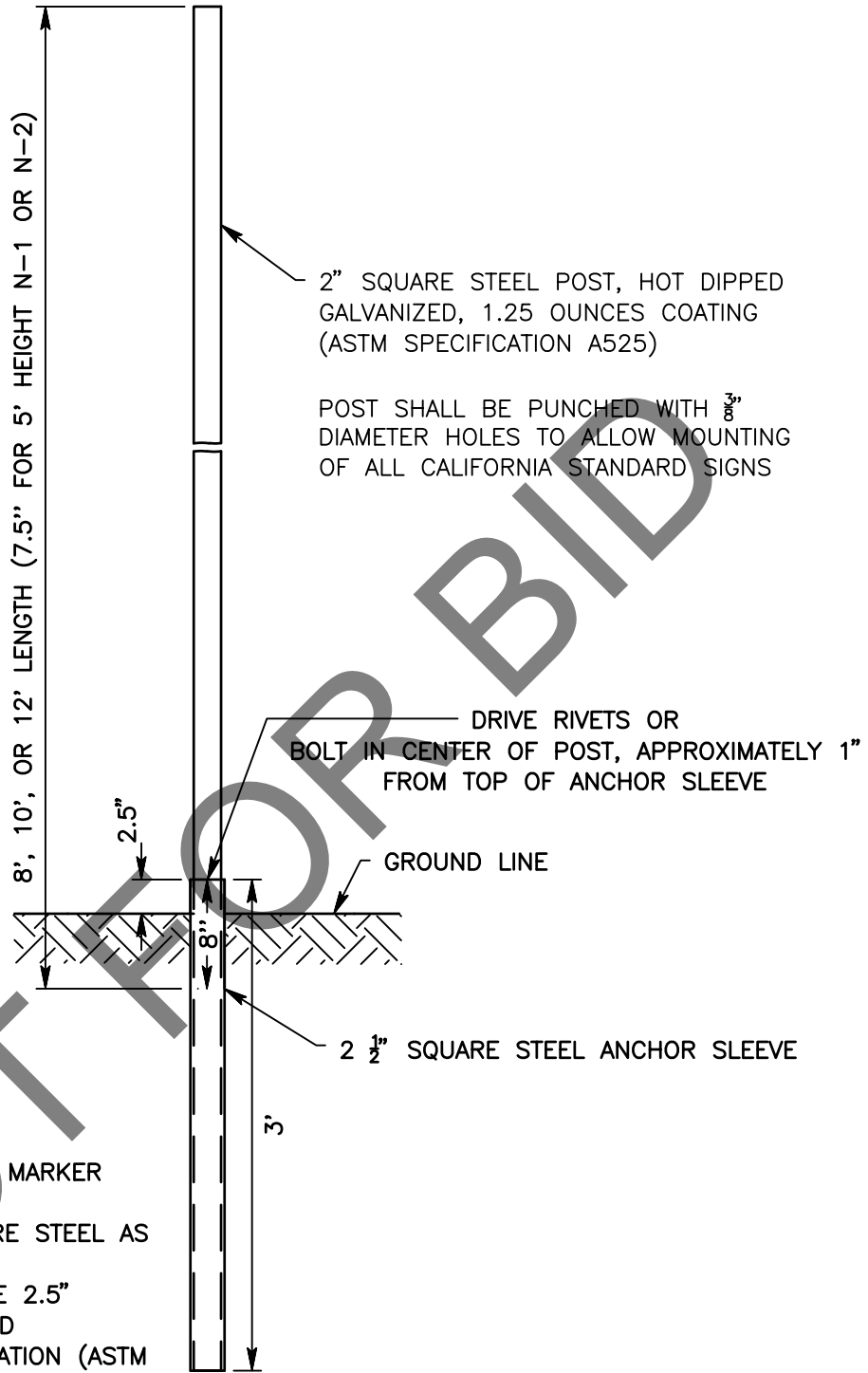

2" SQUARE STEEL POST, HOT DIPPED GALVANIZED, 1.25 OUNCES COATING (ASTM SPECIFICATION A525)

POST SHALL BE PUNCHED WITH $\frac{3}{8}$ " DIAMETER HOLES TO ALLOW MOUNTING OF ALL CALIFORNIA STANDARD SIGNS

DRIVE RIVETS OR BOLT IN CENTER OF POST, APPROXIMATELY 1" FROM TOP OF ANCHOR SLEEVE

GROUND LINE

2 1/2" SQUARE STEEL ANCHOR SLEEVE

NOTES:

1. SEE STANDARD 303A FOR MARKER LOCATIONS.
2. POST SHALL BE 2" SQUARE STEEL AS SHOWN AND STATED.
3. ANCHOR SLEEVE SHALL BE 2.5" SQUARE STEEL HOT DIPPED GALVANIZED AFTER FABRICATION (ASTM SPECIFICATION A-123).
4. SIGNS SHALL BE INSTALLED IN ACCORDANCE WITH STANDARD 303.

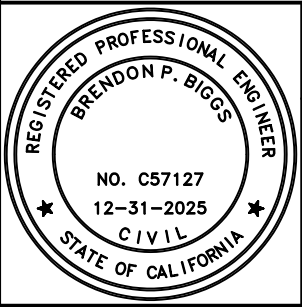

SAN BERNARDINO COUNTY DEPARTMENT OF PUBLIC WORKS

STREET MARKER INSTALLATION

BRENDON P. BIGGS, PE
DIRECTOR OF PUBLIC WORKS/ROAD COMMISSIONER

303B

CALTRANS STANDARD PLANS

2018

NOT FOR BID

Dist	COUNTY	ROUTE	POST MILES TOTAL PROJECT	SHEET NO.	TOTAL SHEETS
<i>Shane N. Tushnet</i> REGISTERED CIVIL ENGINEER					
May 31, 2018 PLANS APPROVAL DATE					
THE STATE OF CALIFORNIA OR ITS OFFICERS OR AGENTS SHALL NOT BE RESPONSIBLE FOR THE ACCURACY OR COMPLETENESS OF SCANNED COPIES OF THIS PLAN SHEET.					



A	
AB	AGGREGATE BASE
ABBC	ASBESTOS BONDED BITUMINOUS COATED
ABM	AIR-BLOWN MORTAR
Abn	ABANDON
ABS	ACRYLONITRILE-BUTADIENE-STYRENE
Abut	ABUTMENT
AC	ASPHALT CONCRETE
AC+	UNGROUND CONDUCTOR
ACB	ASPHALT CONCRETE BASE
ACC	ARMOR-CLAD CONDUCTORS
ACP	ASBESTOS CEMENT PIPE
Adj	ADJUST, ADJUSTABLE, ADJACENT
ADL	ADDED DEAD LOAD
ADT	AVERAGE DAILY TRAFFIC
AFES	ALTERNATIVE FLARED END SECTION
Ahd	AHEAD
AIC	AUXILIARY IRRIGATION CONTROLLER
AIt	ALTERNATE, ALTERNATIVE
AM	TIME FROM MIDNIGHT TO NOON
Amend	AMENDMENT
AP	ALTERNATIVE PIPE
APC	ALTERNATIVE PIPE CULVERT
Approx	APPROXIMATE
APS	ACCESSIBLE PEDESTRIAN SIGNAL
APU	ALTERNATIVE PIPE UNDERDRAIN
ARS	ACCELERATION RESPONSE SPECTRUM
ARV	AIR RELEASE VALVE
AS	AGGREGATE SUBBASE
ASP	ALTERNATIVE SLOTTED PIPE
ASRP	ALUMINUM SPIRAL RIB PIPE
Assy	ASSEMBLY
ATPB	ASPHALT TREATED PERMEABLE BASE
ATPM	ASPHALT TREATED PERMEABLE MATERIAL
Auto	AUTOMATIC
Aux	AUXILIARY
AVB	ATMOSPHERIC VACUUM BREAKER
Ave	AVENUE
Avg	AVERAGE

B continued	
BP	BOOSTER PUMP, BYPASS
BPA	BACKFLOW PREVENTER ASSEMBLY
BPB	BICYCLE PUSH BUTTON
BPE	BACKFLOW PREVENTER ENCLOSURE
B/PI	BRASS/PLASTIC
Br	BRIDGE
Brg	BEARING
BTU	BRITISH THERMAL UNIT
BV	BALL VALVE
BVC	BEGIN VERTICAL CURVE
BW	BARBED WIRE

C	
C	CONDUIT, CHANNEL (STRUCTURAL STEEL SHAPE)
CAA	CABLE ANCHOR ASSEMBLY
CAP	CORRUGATED ALUMINUM PIPE
CAPA	CORRUGATED ALUMINUM PIPE ARCH
CARV	COMBINATION AIR RELEASE VALVE
CAS	CONSTRUCTION AREA SIGN
CB	CONCRETE BARRIER, CIRCUIT BREAKER, COUPLING BAND, COMPOST BERM
CBW	CONCRETE BLOCK WALL
C-C	CENTER TO CENTER
CCA	CAM COUPLER ASSEMBLY
CCTV	CLOSED CIRCUIT TELEVISION
CEC	CONTROLLER ENCLOSURE CABINET
CG	CENTER OF GRAVITY
CHDPE	CORRUGATED HIGH DENSITY POLYETHYLENE CHANNEL
Chnl	CAST IRON
CIDH	CAST-IN-DRILLED-HOLE
CIP	CAST-IN-PLACE, CAST IRON PIPE
CIPCP	CAST IN PLACE CONCRETE PIPE
CISS	CAST-IN-STEEL-SHELL
CJP	COMPLETE JOINT PENETRATION
Ckt	CIRCUIT
CL	CHAIN LINK
CL-6	CHAIN LINK FENCE (6 FT)
Cl	CLASS
Clr	CLEAR, CLEARANCE
CM	CENTER MARGIN LIGHT
CMP	CORRUGATED METAL PIPE
CMS	CHANGEABLE MESSAGE SIGN
CNC	CONTROL AND NEUTRAL CONDUCTORS
Cntl	CONTROL
Co	COUNTY
Col	COLUMN
Comm	COMMUNICATION
Conc	CONCRETE
Conn	CONNECTOR
Const	CONSTRUCT, CONSTRUCTION
Cont	CONTINUOUS
Coord	COORDINATE
CP	CANDLEPOWER, COPPER PIPE

C continued	
Cr	CREEK
CRCP	CONTINUOUSLY REINFORCED CONCRETE PAVEMENT
CRSP	CONCRETE ROCK SLOPE PROTECTION
CS	COMPOST SOCK
CSP	CORRUGATED STEEL PIPE
CSPA	CORRUGATED STEEL PIPE ARCH
CST	CENTER STRIP
ct	COURT
CTB	CEMENT TREATED BASE
CTID	CALTRANS IDENTIFICATION
CTPB	CEMENT TREATED PERMEABLE BASE
CTPM	CEMENT TREATED PERMEABLE MATERIAL
Ctrns	CENTERS
Culv	CULVERT
CV	CHECK VALVE

D	
D	DEPTH, DIRECTION (IN PERCENT) OF HEAVIER TRAFFIC FLOW
Dbi	DOUBLE
DD	DOWNDRAIN
Deg	DEGREE
Del	DELINEATOR
Det	DETAIL, DETOUR
DF	DOUGLAS FIR
DG	DECOMPOSED GRANITE
DHV	DESIGN HOURLY VOLUME
DI	DRAINAGE INLET, DROP INLET
Dia	DIAMETER
Diaph	DIAPHRAGM
DIP	DUCTILE IRON PIPE
Dist	DISTANCE, DISTRICT
DIT	DRIP IRRIGATION TUBING
DLC	LOOP DETECTOR LEAD-IN CABLE
DMBB	DOUBLE METAL BEAM BARRIER
DN	DIAMETER NOMINAL
Dr	DRIVE
DTBB	DOUBLE THRIE BEAM BARRIER
DVA	DRIP VALVE ASSEMBLY
Dwy	DRIVEWAY

E	
E	EAST
Ease	EASEMENT
EB	END OF BRIDGE, EASTBOUND
EC	END HORIZONTAL CURVE, EROSION CONTROL
ECR	END CURB RETURN
ECTC	EROSION CONTROL TECHNOLOGY COUNCIL
ED	EDGE DRAIN
EDC	EDGE DRAIN CLEANOUT
EDO	EDGE DRAIN OUTLET
EDV	EDGE DRAIN VENT
Elec	ELECTROLIER
Elect	ELECTRIC, ELECTRICAL
Elev	ELEVATION

E continued	
EII	ELBOW
Emb	EMBANKMENT
EMS	EXTINGUISHABLE MESSAGE SIGN
Encl	ENCLOSURE
Engr	ENGINEER
EOD	EDGE OF DECK
EP	EDGE OF PAVEMENT
Eq	EQUATION
ERS	EARTH RETAINING STRUCTURE
ES	EDGE OF SHOULDER
ESA	ENVIRONMENTALLY SENSITIVE AREA
ESAL	EQUIVALENT SINGLE AXLE LOADS
EST	END STRIP
Estb	ESTABLISHMENT
ETW	EDGE OF TRAVELED WAY
EVC	END VERTICAL CURVE
EVUC	EMERGENCY VEHICLE UNIT CABLE
EVUD	EMERGENCY VEHICLE UNIT DETECTOR
EW	ENDWALL
Exc	EXCAVATION
Exist	EXISTING
Exp	EXPANSION
Exp Jt	EXPANSION JOINT
Ext	EXTERIOR
Exwy	EXPRESSWAY

F	
F	FILL, FULL CIRCLE
F & C	FRAME AND COVER
F & G	FRAME AND GRATE
FB	FLOOR BEAM, FLASHING BEACON
FBCA	FLASHING BEACON CONTROL ASSEMBLY
FBS	FLASHING BEACON WITH SLIP BASE
FCV	FLOW CONTROL VALVE
Fdn	FOUNDATION
FEBT	FACING EASTBOUND TRAFFIC
Fert	FERTILIZER
FES	FLARED END SECTION
FF	FILTER FABRIC
FG	FINISH GRADE
FH	FIRE HYDRANT, FLEXIBLE HOSE
Fig	FIGURE
FIPT	FEMALE IRON PIPE THREAD
FIS	FERTILIZER INJECTOR SYSTEM
FL	FLOW LINE
FNBT	FACING NORTHBOUND TRAFFIC
FO	FIBER OPTIC
FOB	FREE ON BOARD
FOC	FACE OF CONCRETE
F/P	FULL/PART CIRCLE
FR	FIBER ROLL
Fr Rd	FRONTAGE ROAD
FS	FAR SIDE, FINISHED SURFACE, FLOW SENSOR
FSBT	FACING SOUTHBOUND TRAFFIC
FSC	FLOW SENSOR CABLE
Ftg	FOOTING
FV	FLUSH VALVE
FWBT	FACING WESTBOUND TRAFFIC
Fwy	FREEWAY

- GENERAL RULES:**
- Words are preferred over abbreviations and acronyms.
 - Use words in notes, except where space is limited on the plan sheet.
 - Do not use abbreviations or acronyms where the meaning may be in doubt.
 - Abbreviations and acronyms may be used in callouts, dimensions, and tables.
 - Use upper and lower case letters for abbreviation of a single word. e.g., Misc = miscellaneous and Bit Ctd = bituminous coated
 - Use all upper case letters for acronyms. e.g., BCR = begin curb return

- UNITS OF MEASUREMENT:**
- See Tables A, B and C on Standard Plan A3C.
 - Units of measurement are not part of abbreviations and acronyms. The above abbreviation and acronym general rules do not apply.

- SYMBOLS:**
- See Table D on Standard Plan A3C.

- SLOPES, FLARES, AND TAPERS:**
- Side slopes:
X:Y - horizontal:vertical
 - Flares and tapers:
X:Y - longitudinal:lateral

STATE OF CALIFORNIA
DEPARTMENT OF TRANSPORTATION
**ABBREVIATIONS
(SHEET 1 OF 3)**

A3A

DIST	COUNTY	ROUTE	POST MILES TOTAL PROJECT	SHEET NO.	TOTAL SHEETS
<i>Shane N. Tushnet</i> REGISTERED CIVIL ENGINEER					
May 31, 2018 PLANS APPROVAL DATE					
THE STATE OF CALIFORNIA OR ITS OFFICERS OR AGENTS SHALL NOT BE RESPONSIBLE FOR THE ACCURACY OR COMPLETENESS OF SCANNED COPIES OF THIS PLAN SHEET.					



G	
G	GROOVE, EQUIPMENT GROUNDING CONDUCTOR
g	ACCELERATION DUE TO GRAVITY
Ga	GAUGE
Galv	GALVANIZED
GARV	GARDEN VALVE
GARVA	GARDEN VALVE ASSEMBLY
GB	GROUND BUS
GFCI	GROUND FAULT CIRCUIT INTERRUPTER
GM	GRAVEL MULCH
GP	GRADING PLANE
GPH	GALLONS PER HOUR
GPM	GALLONS PER MINUTE
GR	GUARD RAILING
Grn	GREEN
GSP	GALVANIZED STEEL PIPE
Gtr	GUTTER
GV	GATE VALVE
H	
H	HEIGHT, HALF CIRCLE
HAR	HIGHWAY ADVISORY RADIO
h, hr	HOUR
HD	HORIZONTAL DRAIN
HDPE	HIGH DENSITY POLYETHYLENE
hdw	HEADWALL
Hex	HEXAGONAL
Hex Hd	HEXAGONAL HEAD
HMA	HOT MIX ASPHALT
Horiz	HORIZONTAL
HOV	HIGH OCCUPANCY VEHICLE
HP	HINGE POINT, HORSEPOWER
HPL	HIGH PRESSURE LINE
HPS	HIGH PERFORMANCE STEEL, HIGH PRESSURE SODIUM
HS	HIGH STRENGTH
HSS	HOLLOW STRUCTURAL SECTION
HW	HEADWALL, HIGH WATER
HWM	HIGH WATER MARK
Hwy	HIGHWAY
I	
IB	IMPORTED BORROW
IC	IRRIGATION CONTROLLER
ICC	IRRIGATION CONTROLLER(S) IN CONTROLLER ENCLOSURE CABINET
ID	INSIDE DIAMETER
IF	INSIDE FACE
IFS	IRRIGATION FILTRATION SYSTEM
IISNS	INTERNALLY ILLUMINATED STREET NAME SIGN
Int	INTERIOR
Inv	INVERT
IPS	IRON PIPE SIZE
IPT	IRON PIPE THREAD
Irr	IRRIGATION
ISL	INDUCTION SIGN LIGHTING
J	
Jc+	JUNCTION
JP	JOINT POLE
JPCP	JOINTED PLAIN CONCRETE PAVEMENT
JS	JUNCTION STRUCTURE
J+	JOINT

K	
L	
L	LENGTH, ANGLE (STRUCTURAL STEEL SHAPE)
Lat	LATITUDE
LCB	LEAN CONCRETE BASE
LED	LIGHT EMITTING DIODE
LMA	LUMINAIRE MAST ARM
Ln	LANE
Loc	LOCATION
LOL	LAYOUT LINE
Long	LONGITUDE
Longit	LONGITUDINAL
LPS	LOW PRESSURE SODIUM
LS	LUMP SUM
L+	LEFT
Ltg	LIGHTING
Lum	LUMINAIRE
M	
M	METERED
Maint	MAINTENANCE
MAS	MAST ARM MOUNTING SIDE ATTACHMENT
MAT	MAST ARM MOUNTING TOP ATTACHMENT
Max	MAXIMUM
MB	METAL BEAM
MBB	METAL BEAM BARRIER
MBGR	METAL BEAM GUARD RAILING
MBPS	MANUAL BYPASS SWITCH
MCV	MANUAL CONTROL VALVE
Med	MEDIAN
MGS	MIDWEST GUARDRAIL SYSTEM
MH	MANHOLE
MIC	MASTER IRRIGATION CONTROLLER
Min	MINIMUM
MIPT	MALE IRON PIPE THREAD
Misc	MISCELLANEOUS
Misc I & S	MISCELLANEOUS IRON AND STEEL
Mkr	MARKER
M/M	MULTIPLE TO MULTIPLE TRANSFORMER
Mod	MODIFIED, MODIFY
Mon	MONUMENT
MP	METAL PLATE
MPGR	METAL PLATE GUARD RAILING
MR	MOVEMENT RATING
MSE	MECHANICALLY STABILIZED EMBANKMENT
M+	MOUNTAIN, MOUNT
Mtg	MOUNTING
Mtl	MATERIAL
MV	MERCURY VAPOR LIGHTING FIXTURE
MVDS	MICROWAVE VEHICLE DETECTION SYSTEM
MVP	MAINTENANCE VEHICLE PULLOUT
N	
N	NORTH, NEUTRAL (GROUNDED CONDUCTOR)
NB	NORTHBOUND, NEUTRAL BUS
NC	NORMALLY CLOSE

N continued	
NCN	NO COMMON NAME
NL	NOZZLE LINE
NO	NORMALLY OPEN
No.	NUMBER (MUST HAVE PERIOD)
Nos.	NUMBERS (MUST HAVE PERIOD)
NPS	NOMINAL PIPE SIZE
NPT	NATIONAL PIPE THREAD
NS	NEAR SIDE
NTS	NOT TO SCALE
O	
obl	OBLITERATE
OC	OVERCROSSING
O/C	ON CENTER
OD	OUTSIDE DIAMETER
OF	OUTSIDE FACE
OG	ORIGINAL GROUND
OGAC	OPEN GRADED ASPHALT CONCRETE
OGFC	OPEN GRADED FRICTION COURSE
OH	OVERHEAD
OHWM	ORDINARY HIGH WATER MARK
OL	OVERLAP
O-O	OUT TO OUT
Opp	OPPOSITE
OSD	OVERSIDE DRAIN
P	
P	PAGE, PITCH, PART CIRCLE, NUMBER OF POLES FOR A CIRCUIT BREAKER
PAP	PERFORATED ALUMINUM PIPE
PB	RULL BOX
PBA	PUSH BUTTON ASSEMBLY
PC	POINT OF CURVATURE, PRECAST
PCC	POINT OF COMPOUND CURVE, PORTLAND CEMENT CONCRETE
PCMS	PORTABLE CHANGEABLE MESSAGE SIGN
PCP	PERFORATED CONCRETE PIPE, PRESTRESSED CONCRETE PIPE
PCVC	POINT OF COMPOUND VERTICAL CURVE
PE	POLYETHYLENE
PEC	PERMIT TO ENTER AND CONSTRUCT, PHOTOELECTRIC CONTROL
Ped	PEDESTRIAN
Ped OC	PEDESTRIAN OVERCROSSING
Ped UC	PEDESTRIAN UNDERCROSSING
Perm Mtl	PERMEABLE MATERIAL
PEU	PHOTOELECTRIC UNIT
PG	PROFILE GRADE
PJ	POINT OF INTERSECTION
PJP	PARTIAL JOINT PENETRATION
Pkt	PACKET
Pkwy	PARKWAY

P continued	
PL	PLATE
PI	PLASTIC
P/L	PROPERTY LINE
PLS	PURE LIVE SEED
Pl+	PLANT,
Plt	PLANTING
Plt Estb	PLANT ESTABLISHMENT
PM	POST MILE, TIME FROM NOON TO MIDNIGHT
PN	PAVING NOTCH
POC	POINT OF HORIZONTAL CURVE
POT	POINT OF TANGENT
POVC	POINT OF VERTICAL CURVE
PP	PIPE PILE, PLASTIC PIPE, POWER POLE
PPL	PREFORMED PERMEABLE LINER
PPP	PERFORATED PLASTIC PIPE
PR	PRESSURE RATED
PRC	POINT OF REVERSE CURVE
PRF	PAVEMENT REINFORCING FABRIC
PRLV	PRESSURE RELIEF VALVE
PRV	PRESSURE REGULATING VALVE
PRVC	POINT OF REVERSE VERTICAL CURVE
PS&E	PLANS, SPECIFICATIONS AND ESTIMATES
PS	PRESTRESSED
P/S	PRESTRESSED
PSP	PERFORATED STEEL PIPE
PT	POINT OF TANGENCY, CONDUIT WITH PULL TAPE
PTR	POWER TRANSFER RELAY
PVC	POLYVINYL CHLORIDE
Pvmt	PAVEMENT
Q	
Q	QUARTER CIRCLE
QCV	QUICK COUPLING VALVE
Qty	QUANTITY
R	
R	RADIUS
R & D	REMOVE AND DISPOSE
R & S	REMOVE AND SALVAGE
R/C	RATE OF CHANGE
RCA	REINFORCED CONCRETE ARCH
RCB	REINFORCED CONCRETE BOX
RCP	REINFORCED CONCRETE PIPE
RCPA	REINFORCED CONCRETE PIPE ARCH
RCV	REMOTE CONTROL VALVE
RCVM	REMOTE CONTROL VALVE (MASTER)
RCVMF	REMOTE CONTROL VALVE (MASTER) W/FLOW SENSOR
RCVP	REMOTE CONTROL VALVE W/PRESSURE REGULATOR
RCW	RECYCLED WATER
Rd	ROAD
Rdwy	ROADWAY
RE	RELOCATED EQUIPMENT
RECP	ROLLED EROSION CONTROL PRODUCT
Reinf	REINFORCED, REINFORCEMENT, REINFORCING

STATE OF CALIFORNIA
DEPARTMENT OF TRANSPORTATION
ABBREVIATIONS
(SHEET 2 OF 3)

A3B

R continued

Rel	RELOCATE
Repl	REPLACEMENT
Req	REQUIRED
Ret	RETAINING
Rev	REVISED, REVISION
RHMA	RUBBERIZED HOT MIX ASPHALT
RICS	REMOTE IRRIGATION CONTROL SYSTEM
Riv	RIVER
RM	ROAD-MIXED, RAMP METERING
RP	RADIUS POINT, REFERENCE POINT
RR	RAILROAD
RSP	ROCK SLOPE PROTECTION, REVISED STANDARD PLAN
Rt	RIGHT
Rte	ROUTE
RW	REDWOOD, RETAINING WALL
R/W	RIGHT OF WAY
RWIS	ROADSIDE WEATHER INFORMATION SYSTEM
Rwy	RAILWAY

S

S	SOUTH, SLIP, SUPPLEMENT
SAE	STRUCTURE APPROACH EMBANKMENT
Salv	SALVAGE
SAPP	STRUCTURAL ALUMINUM PLATE PIPE
SB	SOUTHBOUND, SLIP BASE
SC	SAND CUSHION
S/C	SAW CUT LINE
Sch	SCHEDULE
SCSP	SLOTTED CORRUGATED STEEL PIPE
SD	STORM DRAIN
Sec	SECOND, SECTION
Sep	SEPARATION
SG	SUBGRADE
Shld	SHOULDER
Sht	SHEET
SIC	SIGNAL INTERCONNECT CABLE
Sig	SIGNAL
Sim	SIMILAR
SM	SELECTED MATERIAL
SMA	SIGNAL MAST ARM
SNS	STREET NAME SIGN
SP	STAND PIPE, SERVICE POINT
Spec	SPECIAL, SPECIFICATION(S)
SPP	SLOTTED PLASTIC PIPE

S continued

Sq	SQUARE
SS	SLOPE STAKE
SSBM	STRAP AND SADDLE BRACKET METHOD
SSD	STRUCTURAL SECTION DRAIN
SSPA	STRUCTURAL STEEL PLATE ARCH
SSPP	STRUCTURAL STEEL PLATE PIPE
SSPPA	STRUCTURAL STEEL PLATE PIPE ARCH
SSRP	STEEL SPIRAL RIB PIPE
SST	SIDE STRIP
St	STREET
Sta	STATION
STBB	SINGLE THRIE BEAM BARRIER
Std	STANDARD
Str	STRUCTURE
Surf	SURFACING
SW	SIDEWALK, SOUND WALL
Swr	SEWER
Sym	SYMMETRICAL
S4S	SURFACE 4 SIDES

T

T	SEMI-TANGENT, THIRD CIRCLE, THREAD, TRUCK TRAFFIC VOLUME (IN PERCENT) OF DESIGN HOURLY VOLUME
Tan	TANGENT
TB	TERMINAL BOARD
TBB	THRIE BEAM BARRIER
Tbr	TIMBER
T&B	TOP AND BOTTOM
TCB	TRAFFIC CONTROL BOX
TCE	TEMPORARY CONSTRUCTION EASEMENT
TDC	TELEPHONE DEMARCATION CABINET
Temp	TEMPORARY, TEMPERATURE, TEMPERED
TG	TOP OF GRADE
TI	TRAFFIC INDEX
TLS	TRUCK LOADING STAND PIPE
TMS	TRAFFIC MONITORING STATION
TOS	TRAFFIC OPERATIONS SYSTEM
ToT	TOTAL
TP	TELEPHONE POLE
TPB	TREATED PERMEABLE BASE
TPM	TREATED PERMEABLE MATERIAL
TO	THREE-QUARTER CIRCLE
Trans	TRANSITION
TRM	TURF REINFORCEMENT MAT
TS	TRANSVERSE, TRAFFIC SIGNAL, TUBULAR STEEL
TT	TWO-THIRDS CIRCLE
TWSA	TREE WELL SPRINKLER ASSEMBLY
Typ	TYPICAL

U

UC	UNDERCROSSING
UD	UNDERDRAIN
UG	UNDERGROUND
UON	UNLESS OTHERWISE NOTED
UP	UNDERPASS
UPS	UNINTERRUPTIBLE POWER SUPPLY
UPSC	UNINTERRUPTIBLE POWER SUPPLY CONTROLLER
UPSM	UPS MODE

V

V	VALVE, DESIGN SPEED
Var	VARIABLE, VARIES
VC	VERTICAL CURVE
VCP	VITRIFIED CLAY PIPE
Veh	VEHICLE
Vert	VERTICAL
Via	VIADUCT
VIVDS	VIDEO IMAGE VEHICLE DETECTION SYSTEM
Vol	VOLUME

W

W	WEST, WIDTH
W/	WITH
W/O	WITHOUT
WB	WESTBOUND
WH	WEEP HOLE
WhT	WHITE
WIM	WEIGH-IN-MOTION
WM	WIRE MESH, WATER METER
WS	WATER SURFACE, WYE STRAINER
WSA	WYE STRAINER ASSEMBLY
WSP	WELDED STEEL PIPE
Wt	WEIGHT
wv	WATER VALVE
WW	WINGWALL
WWLQ	WINGWALL LAYOUT LINE
WWM	WELDED WIRE MESH

X

Xfmr	TRANSFORMER
X Sec	CROSS SECTION
Xing	CROSSING

Y

Yr	YEAR
Yrs	YEARS

Z

UNITS OF MEASUREMENT:

Some of the units used in the project plan quantity tables and in the Bid Item List are:

TABLE A	
UNIT	DEFINITION
ACRE	ACRE
CF	CUBIC FOOT
CY	CUBIC YARD
EA	EACH
GAL	GALLON
LB	POUND
LF	LINEAR FOOT
LNMI	LANE MILE
LS	LUMP SUM
SQFT	SQUARE FOOT
SQYD	SQUARE YARD
STA	100 FEET
TON	2,000 POUNDS

Some of the units used in the plans other than in the project plan quantity tables are:

TABLE B	
UNIT	DEFINITION
ksi	KIPS PER SQUARE INCH
ksf	KIPS PER SQUARE FOOT
psi	POUNDS PER SQUARE INCH
psf	POUNDS PER SQUARE FOOT
lb/ft ³ , pcf	POUNDS PER CUBIC FOOT
tsf	TONS PER SQUARE FOOT
mph, MPH *	MILES PER HOUR
oz	OUNCE
lb	POUND
kip	1,000 POUNDS
cal	CALORIE
ft	FOOT OR FEET
gal	GALLON

* For use on a sign panel only

Dist	COUNTY	ROUTE	POST MILES TOTAL PROJECT	SHEET NO.	TOTAL SHEETS
<i>Alfred N. Tushnet</i> REGISTERED CIVIL ENGINEER					
May 31, 2018					
PLANS APPROVAL DATE					
<small>THE STATE OF CALIFORNIA OR ITS OFFICERS OR AGENTS SHALL NOT BE RESPONSIBLE FOR THE ACCURACY OR COMPLETENESS OF SCANNED COPIES OF THIS PLAN SHEET.</small>					

Some of the units used in the Electrical plans are:

TABLE C

UNIT	DEFINITION
A	AMPERE
bps	BITS PER SECOND
Bps	BYTES PER SECOND
FC	FOOT-CANDLE
Hz	HERTZ
k *	KILO
kV	KILOVOLT
kVA	KILOVOLT-AMPERE
kW	KILOWATT
M *	MEGA
m *	MILLI
mA	MILLIAMPERE
min	MINUTE
P *	PICO
s	SECOND
V	VOLT
VA	VOLT-AMPERE
V(ac)	VOLT (DIRECT CURRENT)
V(ac)	VOLT (ALTERNATING CURRENT)
W	WATT
Ω	OHM
μ *	MICRO

* Prefix to a unit

SYMBOLS:

Commonly used symbols for U.S. customary units

TABLE D

SYMBOL	DEFINITION
@	AT
CL	CENTERLINE
φ	NOMINAL DIAMETER, DIAMETER, PHASE
PL	PLATE
ST	STATIONLINE

STATE OF CALIFORNIA
DEPARTMENT OF TRANSPORTATION

**ABBREVIATIONS
(SHEET 3 OF 3)**

A3C

2018 STANDARD PLAN A3C

Return to Table of Contents

LEFT EDGELINES

(DIVIDED HIGHWAYS)

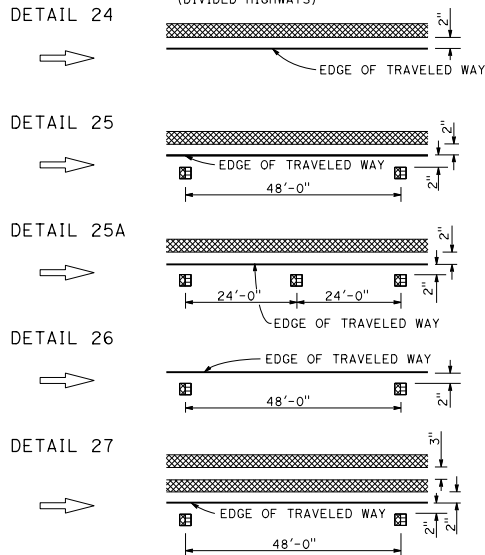

RIGHT EDGELINES

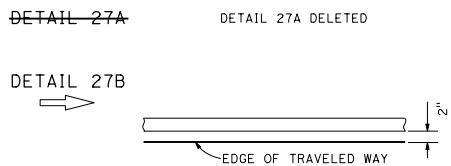

RIGHT EDGELINE EXTENSION THROUGH INTERSECTIONS

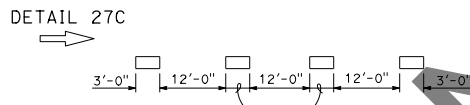

MEDIAN ISLANDS

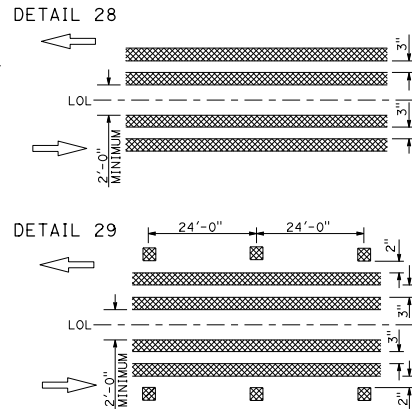

DETAIL 30 DELETED

TWO-WAY LEFT TURN LANES

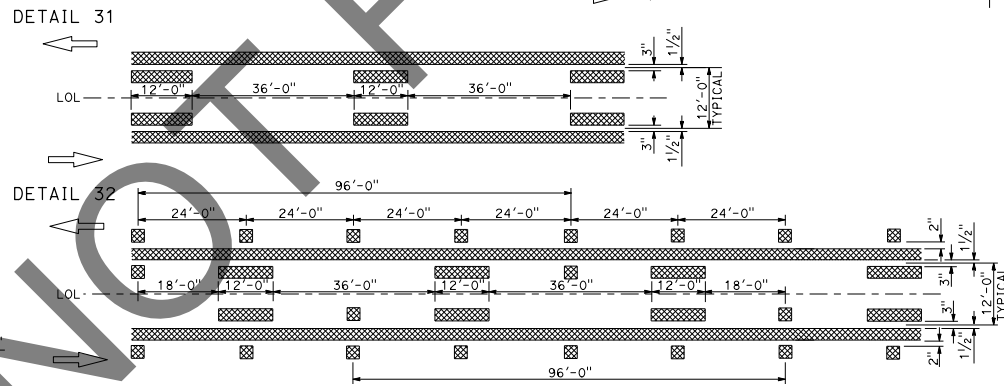

DETAIL 33 DELETED

LEGEND

- MARKERS
- TYPE D TWO-WAY YELLOW RETROREFLECTIVE
 - TYPE H ONE-WAY YELLOW RETROREFLECTIVE
 - TYPE RY RED-YELLOW RETROREFLECTIVE
- LINES
- 6" WHITE
 - 6" YELLOW

INTERSECTION TREATMENTS

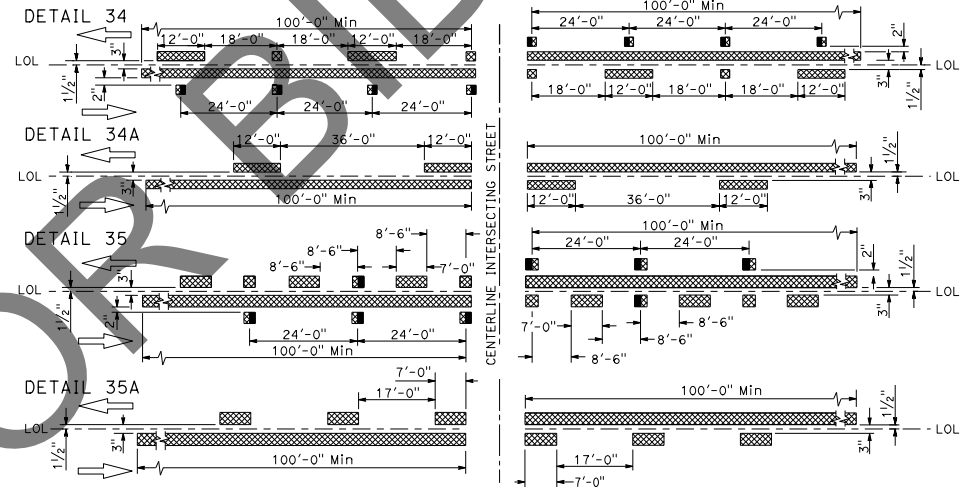

MARKER DETAILS

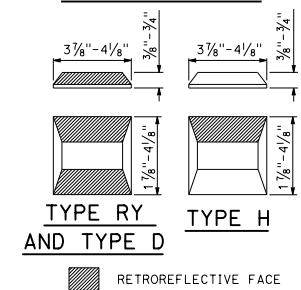

STATE OF CALIFORNIA
DEPARTMENT OF TRANSPORTATION

PAVEMENT MARKERS AND TRAFFIC LINES TYPICAL DETAILS

NO SCALE

A20B

DIST	COUNTY	ROUTE	POST MILES TOTAL PROJECT	SHEET NO.	TOTAL SHEETS

Atifa Ferouz
REGISTERED CIVIL ENGINEER

PLANS APPROVAL DATE
Mcy 31, 2018
No. C80402
EXP. 3-31-19
CIVIL

THE STATE OF CALIFORNIA OR ITS OFFICERS OR AGENTS SHALL NOT BE RESPONSIBLE FOR THE ACCURACY OR COMPLETENESS OF SCANNED COPIES OF THIS PLAN SHEET.

LEFT EDGE LINES

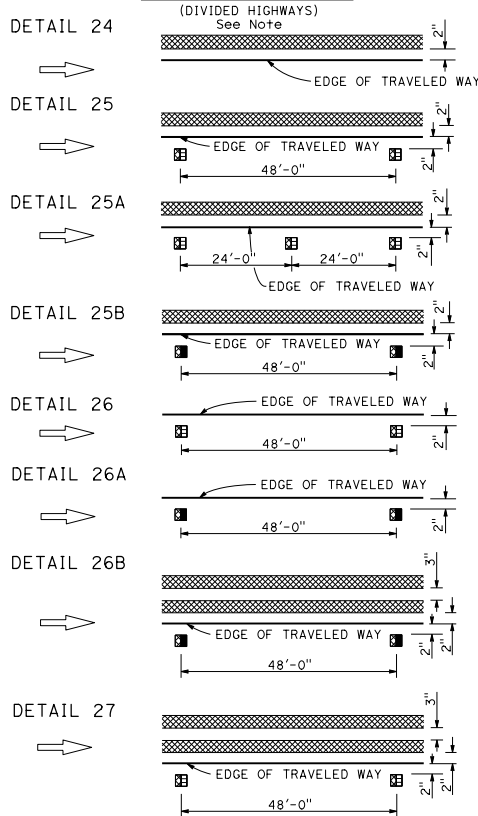

RIGHT EDGE LINES

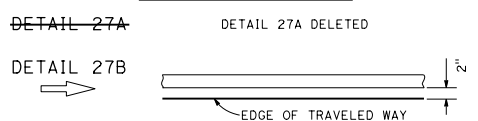

RIGHT EDGE LINE EXTENSION THROUGH INTERSECTIONS

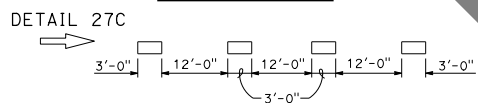

LEFT EDGE LINES NOTE:
On freeways use traffic stripe details with Type RY markers.

MEDIAN ISLANDS

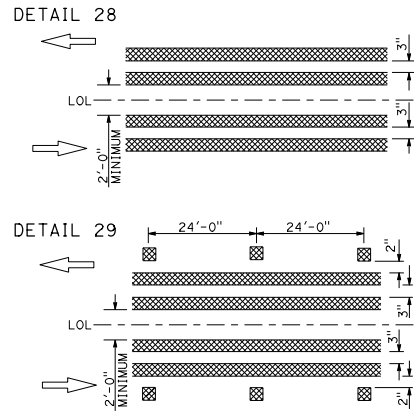

TWO-WAY LEFT TURN LANES

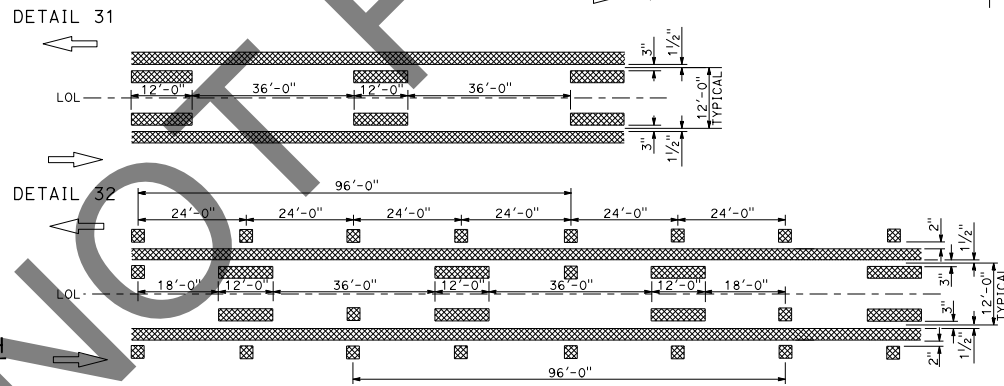

LEGEND

- MARKERS**
- TYPE D TWO-WAY YELLOW RETROREFLECTIVE
 - TYPE H ONE-WAY YELLOW RETROREFLECTIVE
 - TYPE RY RED-YELLOW RETROREFLECTIVE
- LINES**
- 6" WHITE
 - 6" YELLOW

INTERSECTION TREATMENTS

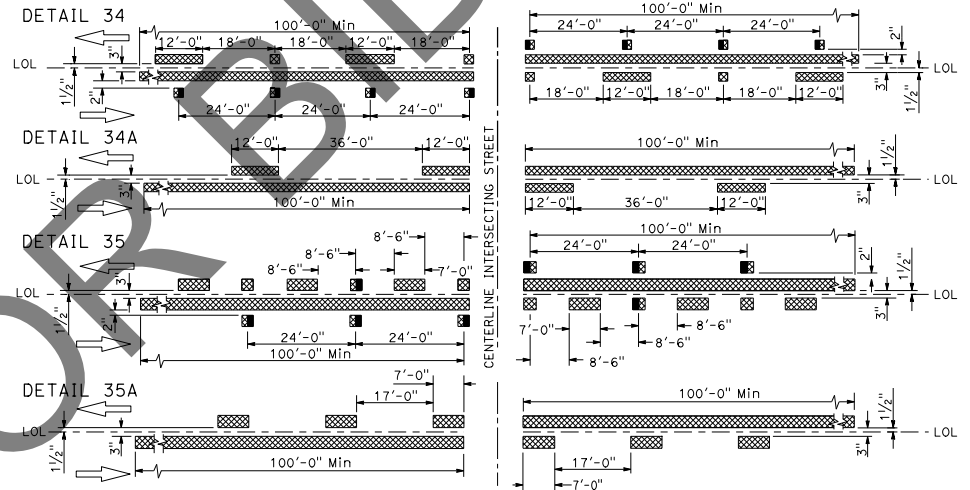

MARKER DETAILS

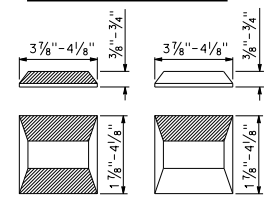

TYPE RY AND TYPE D

TYPE H

RETROREFLECTIVE FACE

STATE OF CALIFORNIA
DEPARTMENT OF TRANSPORTATION

PAVEMENT MARKERS AND TRAFFIC LINES TYPICAL DETAILS

NO SCALE

RSP A20B DATED APRIL 19, 2019 SUPERSEDES STANDARD PLAN A20B
DATED MAY 31, 2018 - PAGE 13 OF THE STANDARD PLANS BOOK DATED 2018.

REVISED STANDARD PLAN RSP A20B

DIST	COUNTY	ROUTE	POST MILES TOTAL PROJECT	SHEET NO.	TOTAL SHEETS

Atifa Ferouz
REGISTERED CIVIL ENGINEER

April 19, 2019
PLANS APPROVAL DATE
No. C80402
EXP. 3-31-21
CIVIL

THE STATE OF CALIFORNIA OR ITS OFFICERS OR AGENTS SHALL NOT BE RESPONSIBLE FOR THE ACCURACY OR COMPLETENESS OF SCANNED COPIES OF THIS PLAN SHEET.

REGISTERED PROFESSIONAL ENGINEER
Atifa Ferouz
No. C80402
EXP. 3-31-21
CIVIL
STATE OF CALIFORNIA

2018 REVISED STANDARD PLAN RSP A20B

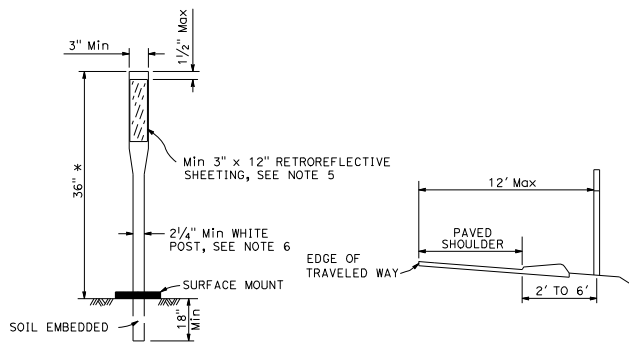

* 36" Min where speeds are 40 miles/h or less.
CHANNELIZERS

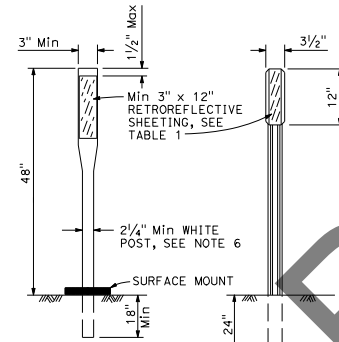

CLASS 1 FLEXIBLE POST
CLASS 2 METAL POST
See Note 4

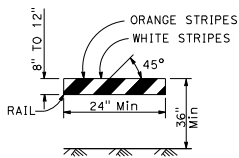

TYPE I BARRICADE
See Note A

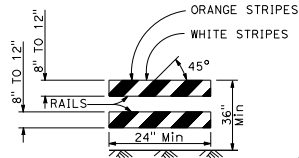

TYPE II BARRICADE

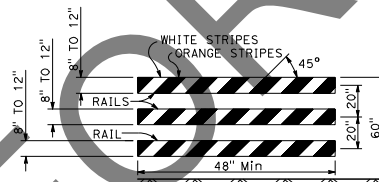

TYPE III BARRICADE

BARRICADES (See Note 3)

Only face of rails shown, barricade construction materials and supports as specified in the specifications.

BARRICADE	TYPE I	TYPE II	TYPE III
WIDTH OF RAIL	8" Min - 12" Max *	8" Min - 12" Max *	8" Min - 12" Max *
LENGTH OF RAIL	24" Min	24" Min	48" Min
WIDTH OF STRIPES **	6"	6"	6"
HEIGHT	36" Min	36" Min	60" Min
NUMBER OF RETROREFLECTIVE RAIL FACES	2 (ONE EACH DIRECTION)	4 (TWO EACH DIRECTION)	3 IF FACING TRAFFIC IN ONE DIRECTION 6 IF FACING TRAFFIC IN TWO DIRECTION

* For the wooden option dimensions are nominal lumber dimensions.
** For rails less than 36" long, 4" wide stripes shall be used.

NOTE A:

Barricades to have a minimum of 270 square inches of retroreflective area facing traffic when used on freeways, expressways, and other high speed highways.

Dist	COUNTY	ROUTE	POST MILES TOTAL PROJECT	SHEET TOTAL No. SHEETS

Atifa Ferouz
REGISTERED CIVIL ENGINEER
No. C80402
May 31, 2018
PLANS APPROVAL DATE
THE STATE OF CALIFORNIA OR ITS OFFICERS OR AGENTS SHALL NOT BE RESPONSIBLE FOR THE ACCURACY OR COMPLETENESS OF SCANNED COPIES OF THIS PLAN SHEET.

TYPE	RETROREFLECTIVE SHEETING	
	FRONT	BACK
E	WHITE	WHITE (SEE NOTE 1)
F	WHITE	NONE
G	YELLOW	NONE
J	RED	NONE

NOTES:

- The retroreflective sheeting used on the back of delineator shall be a minimum size of 3" x 3".
- The type of delineator to be installed will be designated on the plans.
- All barricade stripes shall be retroreflective and sloped downward in the direction of the opened traffic lane.
- See Standard Plan A73B for Metal Post Details.
- Unless shown otherwise on the plans, or as directed by the Engineer, the color of the retroreflective sheeting for permanent channelizers shall conform to the color of the pavement markings it supplements.
- Except, Class 1 (Flexible Post) temporary delineators and temporary channelizers in work zones shall be orange post with white retroreflective sheeting.

STATE OF CALIFORNIA
DEPARTMENT OF TRANSPORTATION
**DELINEATORS, CHANNELIZERS
AND BARRICADES**

NO SCALE

A73C

Dist	COUNTY	ROUTE	POST MILES TOTAL PROJECT	SHEET TOTAL No. SHEETS

Randell D. Hiett
 REGISTERED CIVIL ENGINEER
 No. C50200
 Exp. 6-30-19
 CIVIL
 STATE OF CALIFORNIA

May 31, 2018
 PLANS APPROVAL DATE
THE STATE OF CALIFORNIA OR ITS OFFICERS OR AGENTS SHALL NOT BE RESPONSIBLE FOR THE ACCURACY OR COMPLETENESS OF SCANNED COPIES OF THIS PLAN SHEET.

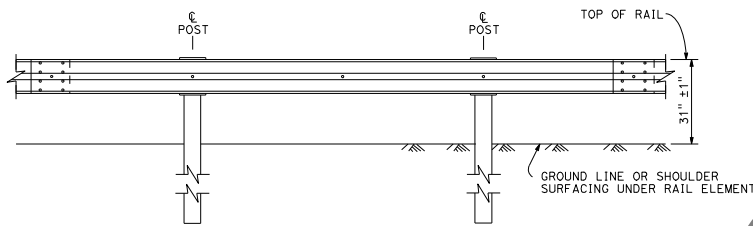
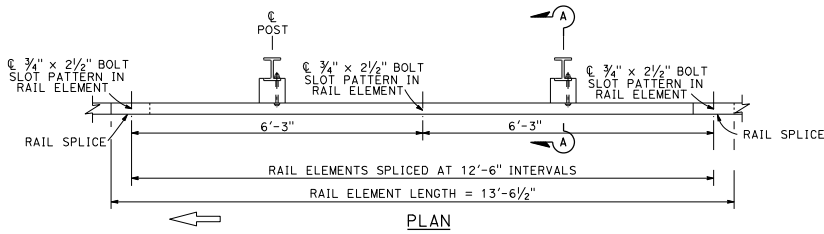

**MIDWEST GUARDRAIL SYSTEM WITH STEEL POSTS
AND NOTCHED WOOD OR NOTCHED RECYCLED PLASTIC BLOCKS**

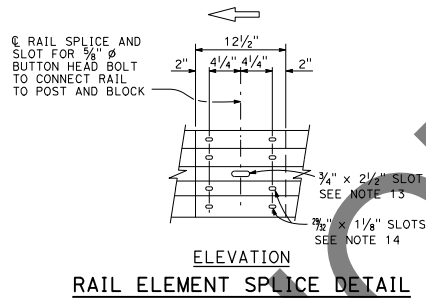

- a) Connect the overlapped end of the rail elements with $\frac{5}{8}$ " ϕ x $1\frac{1}{8}$ " button head oval shoulder splice bolts inserted into the $\frac{3}{4}$ " x $1\frac{1}{4}$ " slots and bolted together with $\frac{3}{8}$ " ϕ recessed hex nuts. Recess of hex nut points toward rail element. A total of 8 bolts and nuts are to be used at each rail splice connection.
- b) The ends of the rail elements are to be overlapped in the direction of traffic (see details).
- c) Where end cap is to be attached to the end of a rail element, a total of 4 of the above described splice bolts and nuts are to be used.

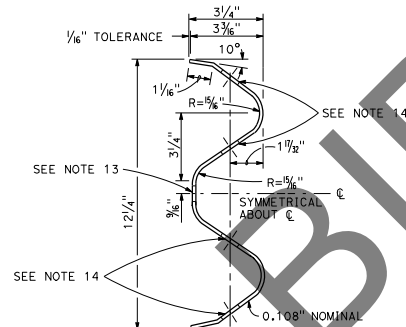

**SECTION THRU
RAIL ELEMENT**

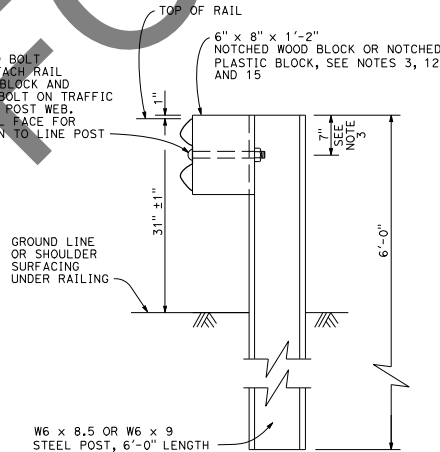

**SECTION A-A
TYPICAL STEEL LINE
POST INSTALLATION**

See Note 4

NOTES:

1. For details of wood post installations, see Standard Plan A77L1.
2. For details of standard hardware used to construct MGS, see Standard Plan A77M1.
3. For details of steel posts and notched wood blocks used to construct MGS, see Standard Plan A77N2.
4. For additional installation details, see Standard Plan A77N3.
5. MGS post spacing to be 6'-3" center to center, except as otherwise noted.
6. For MGS typical layouts, see the A77P, A77Q and A77R Series of Standard Plans.
7. If railing is connected to terminal system end treatment, use 31" height terminal system end treatment.
8. For MGS end anchor details, see Standard Plans A77S1 and A77T2.
9. For details of MGS transition to bridge railing, see Standard Plan A77U4.
10. For additional details of MGS connection to bridge railings, see Standard Plans A77U1, A77U2 and A77V1.
11. For dike positioning and MGS delineation details, see Standard Plan A77N4.
12. Notched face of block faces steel post.
13. Slotted hole for bolted connection of rail element to block and post.
14. Slotted holes for splice bolts to overlap ends of rail element.
15. 6" x 12" x 1'-2" block must be used with 6" dike.

STATE OF CALIFORNIA
DEPARTMENT OF TRANSPORTATION
**MIDWEST GUARDRAIL SYSTEM
STANDARD RAILING SECTION
(STEEL POST WITH NOTCHED
WOOD OR NOTCHED
RECYCLED PLASTIC BLOCK)**

NO SCALE

A77L2

2018 STANDARD PLAN A77L2

DIST	COUNTY	ROUTE	POST MILES TOTAL PROJECT	SHEET No.	TOTAL SHEETS
RANDALL D. HIATT REGISTERED CIVIL ENGINEER No. C50200 Exp. 6-30-19 CIVIL STATE OF CALIFORNIA					
May 31, 2018 PLANS APPROVAL DATE					
THE STATE OF CALIFORNIA OR ITS OFFICERS OR AGENTS SHALL NOT BE RESPONSIBLE FOR THE ACCURACY OR COMPLETENESS OF SCANNED COPIES OF THIS PLAN SHEET.					

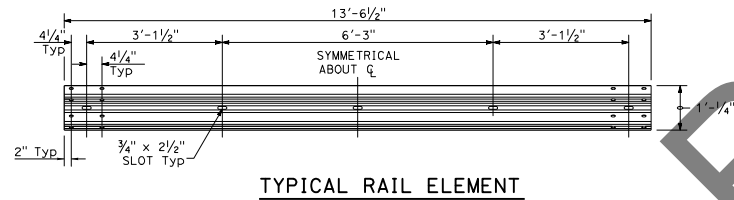

TYPICAL RAIL ELEMENT

NOTE:

1. Slotted holes for splice bolts to overlap ends of rail element.

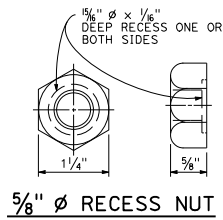

5/8" ϕ RECESS NUT

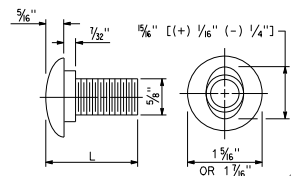

5/8" ϕ BUTTON HEAD BOLT

BUTTON HEAD BOLT

L	THREAD LENGTH
1 3/8"	FULL THREAD LENGTH
2"	FULL THREAD LENGTH
10"	4" Min THREAD LENGTH
18"	4" Min THREAD LENGTH
20"	4" Min THREAD LENGTH
22"	4" Min THREAD LENGTH
26"	4" Min THREAD LENGTH
36"	4" Min THREAD LENGTH
** 2 3/4"	2" Min THREAD LENGTH
** 19"	4" Min THREAD LENGTH

** For nested rail applications.

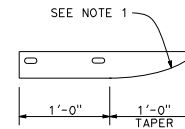

SEE NOTE 1

PLAN

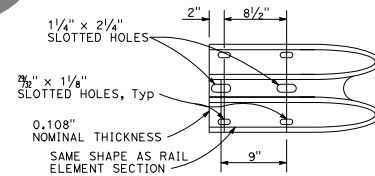

ELEVATION

END CAP

(TYPE A)

STATE OF CALIFORNIA
 DEPARTMENT OF TRANSPORTATION
**MIDWEST GUARDRAIL SYSTEM
 STANDARD HARDWARE**

NO SCALE

A77M1

2018 STANDARD PLAN A77M1

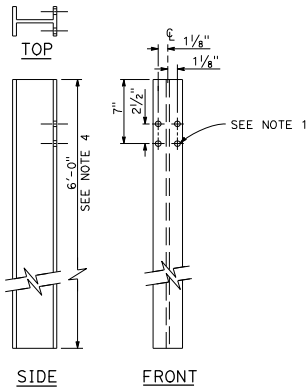

W6 x 9 OR W6 x 8.5
STEEL POST
See Note 4

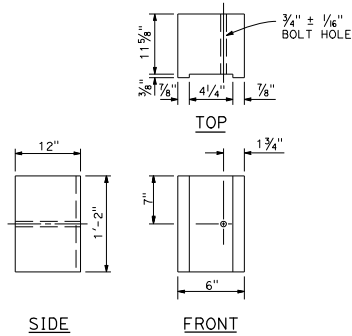

6" x 12"
NOTCHED WOOD BLOCK
See Notes 2, 3 and 7

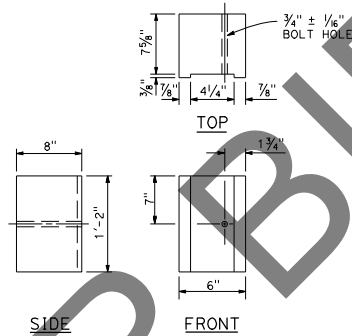

6" x 8"
NOTCHED WOOD BLOCK
Only for use with metal beam guard railing. See Note 5

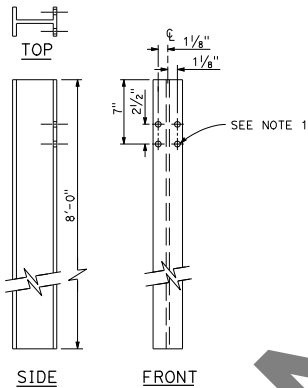

W6 x 9 OR W6 x 8.5
STEEL POST
See Note 6

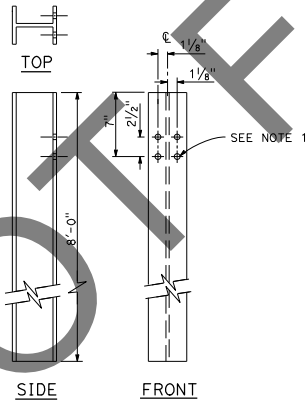

W6 x 15
STEEL POST

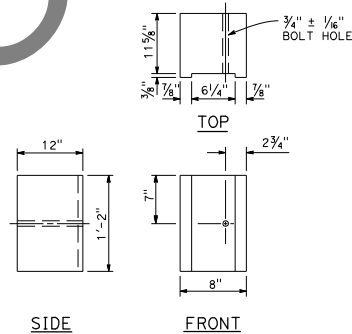

8" x 12"
NOTCHED WOOD BLOCK
See Notes 2, 3 and 7

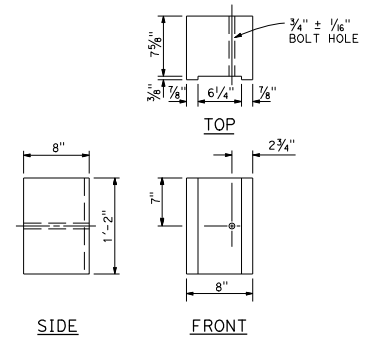

8" x 8"
NOTCHED WOOD BLOCK
Only for use with metal beam guard railing. See Note 5

DIST.	COUNTY	ROUTE	POST MILES TOTAL PROJECT	SHEET NO.	TOTAL SHEETS

Randell D. Hiett
REGISTERED CIVIL ENGINEER

May 31, 2018
PLANS APPROVAL DATE

NO. C50200
Exp. 6-30-19
CIVIL
STATE OF CALIFORNIA

REGISTERED PROFESSIONAL ENGINEER

THE STATE OF CALIFORNIA OR ITS OFFICERS OR AGENTS SHALL NOT BE RESPONSIBLE FOR THE ACCURACY OR COMPLETENESS OF SCANNED COPIES OF THIS PLAN SHEET.

NOTES:

1. All holes in steel post shall be 5/16" Dia maximum.
2. Dimensions shown for wood block are nominal.
3. Notched face of block faces steel post.
4. 6'-0" length posts to be used for typical roadway installation. See Standard Plan A77N3.
5. See Standard Plan A77L3 for use of 6" x 8" and 8" x 8" notched wood blocks.
6. This post and 8" x 12" block combination to be used for line post sections of MGS on narrow roadways and where strengthened line post sections of MGS are warranted to shield fixed objects.
7. 6" x 12" notched wood block and 8" x 12" notched wood block must be used with 6" dike.

STATE OF CALIFORNIA
DEPARTMENT OF TRANSPORTATION
MIDWEST GUARDRAIL SYSTEM
STEEL POST AND
NOTCHED WOOD BLOCK DETAILS
NO SCALE

A77N2

DIST	COUNTY	ROUTE	POST MILES TOTAL PROJECT	SHEET NO.	TOTAL SHEETS

Randell D. Hiatt
 REGISTERED CIVIL ENGINEER

May 31, 2018
 PLANS APPROVAL DATE

No. C60200
 Exp. 6-30-19
 CIVIL

THE STATE OF CALIFORNIA OR ITS OFFICERS OR AGENTS SHALL NOT BE RESPONSIBLE FOR THE ACCURACY OR COMPLETENESS OF SCANNED COPIES OF THIS PLAN SHEET.

NOTES:

1. When necessary to place dike more than 7" in front of face of MGS, only Type C dike may be used. For dike details, see Standard Plan A87B.
2. For standard railing post embedment, see Standard Plan A77N3.
3. MGS delineation to be used where shown on the Project Plans.
4. When dike or curb is placed under MGS, the maximum height of the dike or curb shall be 6". Mountable dike should not be used. For dike and curb details, see Standard Plans A87A and A87B.
5. For details of typical distance between the face of rail and hinge point, see Standard Plan A77N3.
6. For steel line posts, use 1/4" - 20 self-tapping screws in 0.22" diameter holes or 1/4" bolts in 3/8" diameter holes.

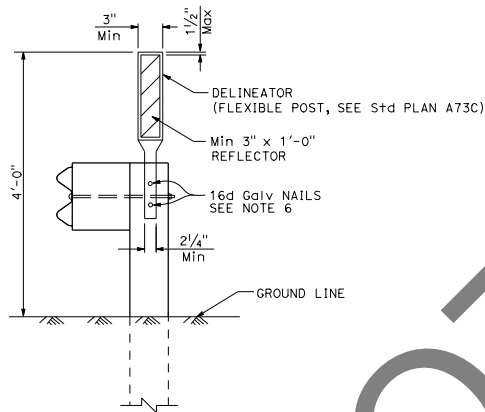

MGS DELINEATION
See Note 3

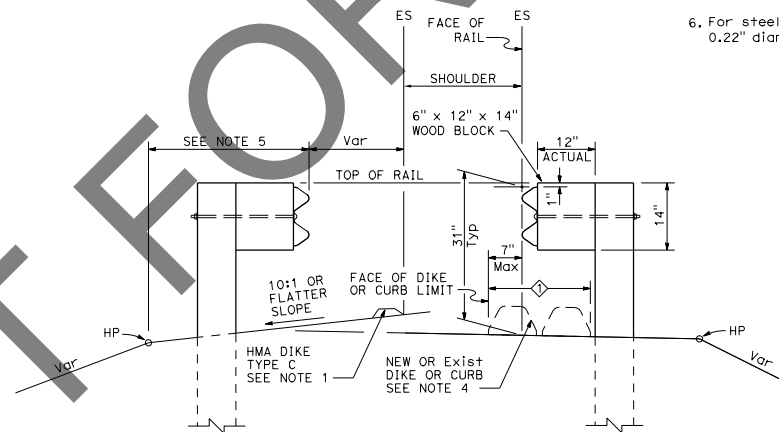

DIKE POSITIONING
See Note 1

◇ PERMISSIBLE DIKE OR CURB PLACEMENT AREA

STATE OF CALIFORNIA
 DEPARTMENT OF TRANSPORTATION
**MIDWEST GUARDRAIL SYSTEM
 TYPICAL RAILING DELINEATION
 AND DIKE POSITIONING DETAILS**
 NO SCALE

A77N4

2018 STANDARD PLAN A77N4

Dist	COUNTY	ROUTE	POST MILES TOTAL PROJECT	SHEET No.	TOTAL SHEETS

Randell D. Hiatt
REGISTERED CIVIL ENGINEER

April 19, 2019
PLANS APPROVAL DATE

THE STATE OF CALIFORNIA OR ITS OFFICERS OR AGENTS SHALL NOT BE RESPONSIBLE FOR THE ACCURACY OR COMPLETENESS OF SCANNED COPIES OF THIS PLAN SHEET.

REGISTERED PROFESSIONAL ENGINEER
No. C50200
Exp. 6-30-19
CIVIL
STATE OF CALIFORNIA

TO ACCOMPANY PLANS DATED _____

NOTES:

- When necessary to place dike more than 7" in front of face of MGS, only Type C dike may be used. For dike details, see Standard Plan A87B.
- For standard railing post embedment, see Standard Plan A77N3.
- MGS delineation to be used where shown on the Project Plans.
- When dike or curb is placed under MGS, the maximum height of the dike or curb shall be 6". Mountable dike should not be used. For dike and curb details, see Standard Plans A87A and A87B.
- For details of typical distance between the face of rail and hinge point, see Standard Plan A77N3.
- For steel line posts, use 1/4" - 20 self-tapping screws in 0.22" diameter holes or 1/4" bolts in 3/8" diameter holes.
- 8" block can be used with 4" or lower dike, or no dike. 12" block can be used with 6" or lower dike, or no dike.

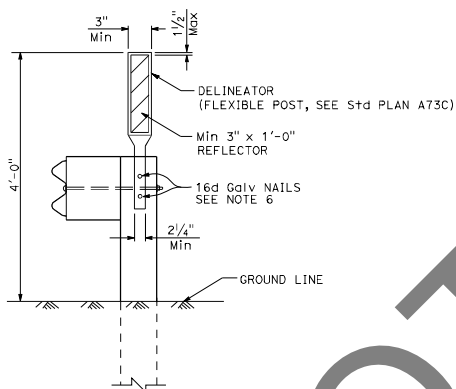

MGS DELINEATION
See Note 3

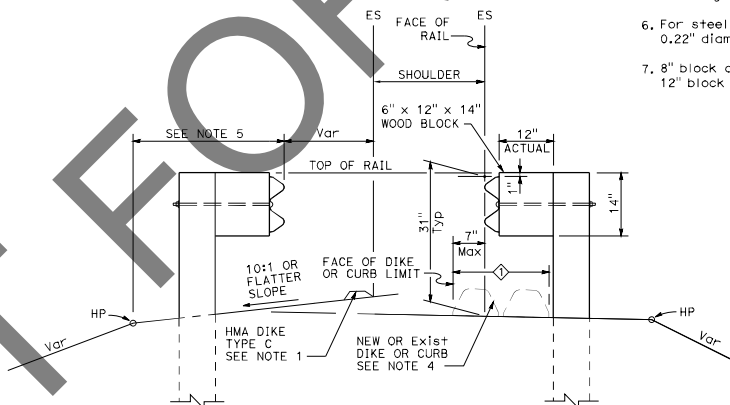

DIKE POSITIONING
See Note 1

◇ PERMISSIBLE DIKE OR CURB
PLACEMENT AREA

STATE OF CALIFORNIA
DEPARTMENT OF TRANSPORTATION

**MIDWEST GUARDRAIL SYSTEM
TYPICAL RAILING DELINEATION
AND DIKE POSITIONING DETAILS**

NO SCALE

RSP A77N4 DATED APRIL 19, 2019 SUPERSEDES STANDARD PLAN A77N4
DATED MAY 31, 2018 - PAGE 64 OF THE STANDARD PLANS BOOK DATED 2018.

REVISED STANDARD PLAN RSP A77N4

2018 REVISED STANDARD PLAN RSP A77N4

Dist	COUNTY	ROUTE	POST MILES TOTAL PROJECT	SHEET No.	TOTAL SHEETS
<i>Chi H. Wong</i> REGISTERED CIVIL ENGINEER No. C54738 Exp. 12-31-19 CIVIL STATE OF CALIFORNIA					
May 31, 2018 PLANS APPROVAL DATE <small>THE STATE OF CALIFORNIA OR ITS OFFICERS OR AGENTS SHALL NOT BE RESPONSIBLE FOR THE ACCURACY OR COMPLETENESS OF SCANNED COPIES OF THIS PLAN SHEET.</small>					

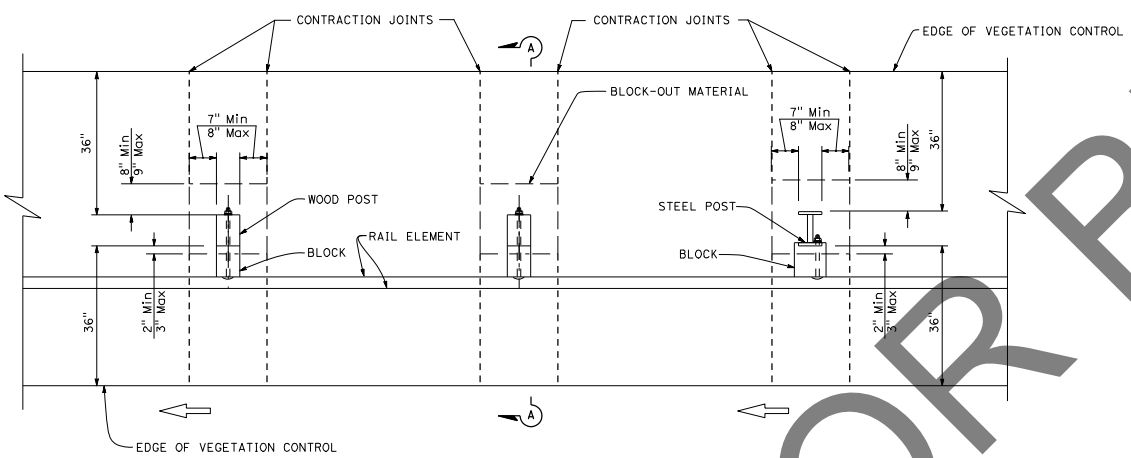

- NOTES:**
1. Where the distance between back of post and hinge point is less than 42", construct vegetation control to 6" from hinge point while maintaining the 8" block-out at back of post.
 2. Where paved shoulder is constructed within 36" in front of the post, construct vegetation control to the edge of paved shoulder.
 3. For wood post sizes, see Standard Plan A77N1.
 4. For steel post sizes, see Standard Plan A77N2.
 5. For details not shown, see Standard Plans A77L1 and A77L2.
 6. Where vegetation control is adjacent to a dike on a cut slope, construct vegetation control flush with the top edge of dike.
 7. Vegetation control must slope to drain water.
 8. Concrete over block-out material depth, construct 3/8" Min to 5/8" Max.
 9. This plan for vegetation control installation only.

PLAN

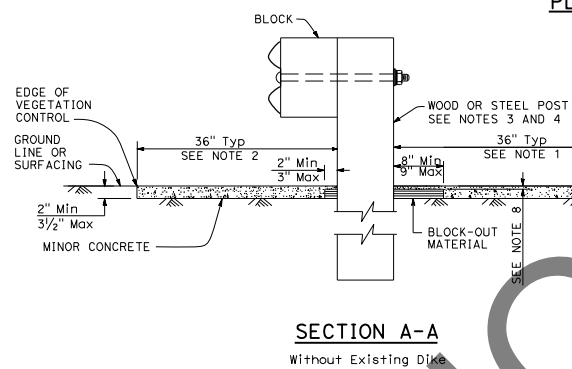

SECTION A-A
Without Existing Dike

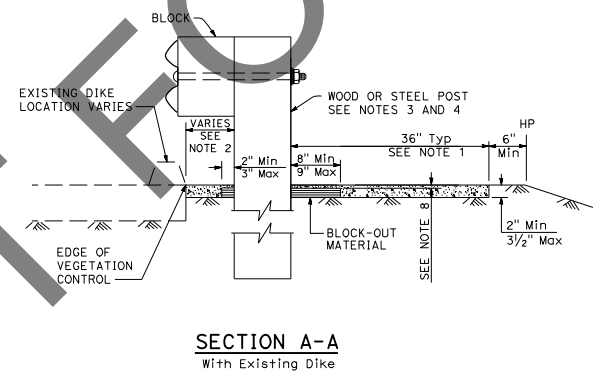

SECTION A-A
With Existing Dike

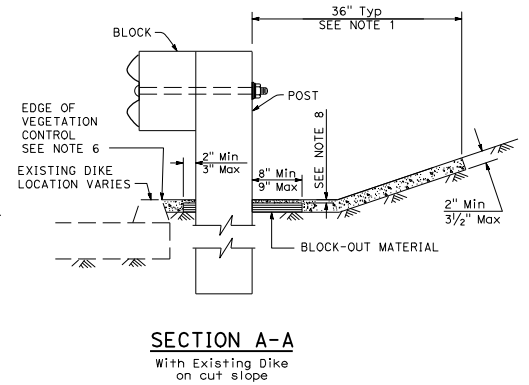

SECTION A-A
With Existing Dike on cut slope

STATE OF CALIFORNIA
DEPARTMENT OF TRANSPORTATION

**MINOR CONCRETE VEGETATION CONTROL
GUARDRAIL SYSTEM**

NO SCALE

A77N5

2018 STANDARD PLAN A77N5

65

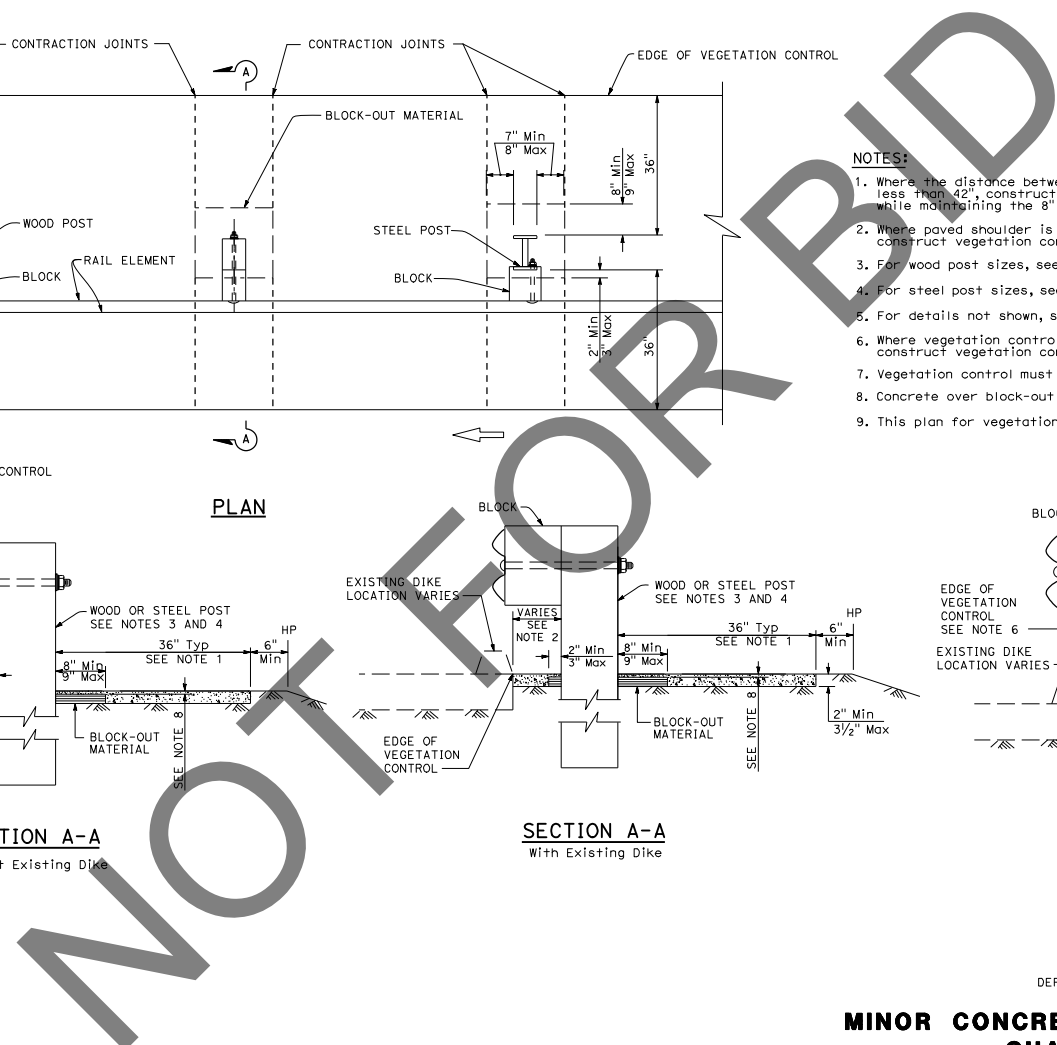

Return to Table of Contents

DIST	COUNTY	ROUTE	POST MILES TOTAL PROJECT	SHEET NO.	TOTAL SHEETS
<i>Chi H. Wong</i> REGISTERED CIVIL ENGINEER					
May 31, 2018 PLANS APPROVAL DATE					
					
<small>THE STATE OF CALIFORNIA OR ITS OFFICERS OR AGENTS SHALL NOT BE RESPONSIBLE FOR THE ACCURACY OR COMPLETENESS OF SCANNED COPIES OF THIS PLAN SHEET.</small>					

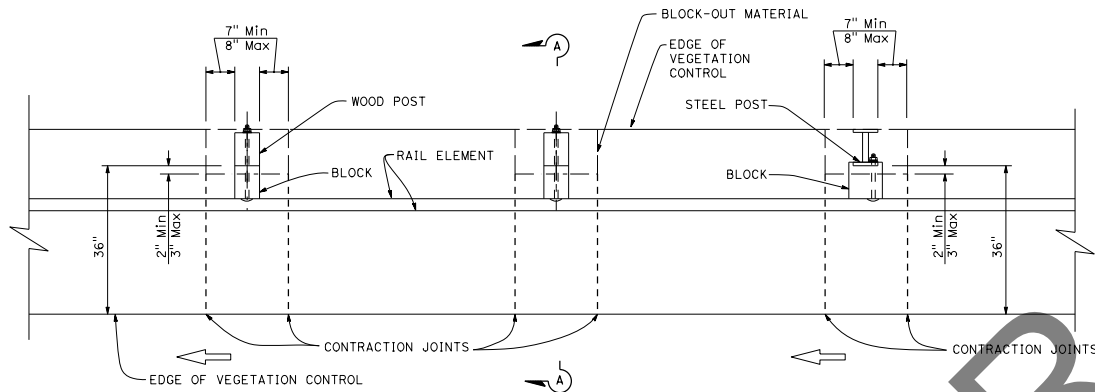

PLAN

NOTES:

1. Use the details on this sheet when the length from the back of post to the hinge point is less than 18". Use the details on Standard Plan A77N5 when the length from the back of the post to the hinge point is greater than 18".
2. Construct vegetation control flush with the back edge of post.
3. Where paved shoulder is constructed within 36" in front of the post, construct vegetation control to the edge of paved shoulder.
4. For wood post sizes, see Standard Plan A77N1.
5. For steel post sizes, see Standard Plan A77N2.
6. For details not shown, see Standard Plans A77L1 and A77L2.
7. Vegetation control must slope to drain water.
8. Concrete over block-out material depth, construct $\frac{3}{8}$ " Min to $\frac{5}{8}$ " Max.
9. This plan for vegetation control installation only.

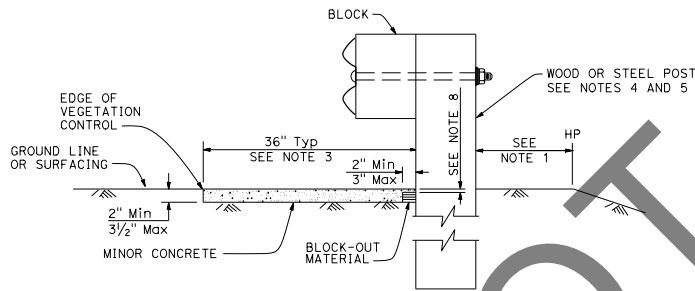

SECTION A-A

Without Existing Dike

STATE OF CALIFORNIA
 DEPARTMENT OF TRANSPORTATION
**MINOR CONCRETE VEGETATION CONTROL
 GUARDRAIL SYSTEM
 NARROW VEGETATION CONTROL INSTALLATION**

NO SCALE

A77N5A

2018 STANDARD PLAN A77N5A

Dist	COUNTY	ROUTE	POST MILES TOTAL PROJECT	SHEET TOTAL SHEETS
<i>Chi H. Wong</i> REGISTERED CIVIL ENGINEER				
May 31, 2018 PLANS APPROVAL DATE				
THE STATE OF CALIFORNIA OR ITS OFFICERS OR AGENTS SHALL NOT BE RESPONSIBLE FOR THE ACCURACY OR COMPLETENESS OF SCANNED COPIES OF THIS PLAN SHEET.				

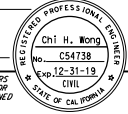

NOTES:

1. See Standard Plan A77N5 for additional vegetation control details.
2. Where the distance between back of post and hinge point is less than 42", construct vegetation control to 6" from hinge point while maintaining the 8" block-out at back of post.
3. Vegetation control must slope to drain water.
4. This plan for vegetation control installation only.

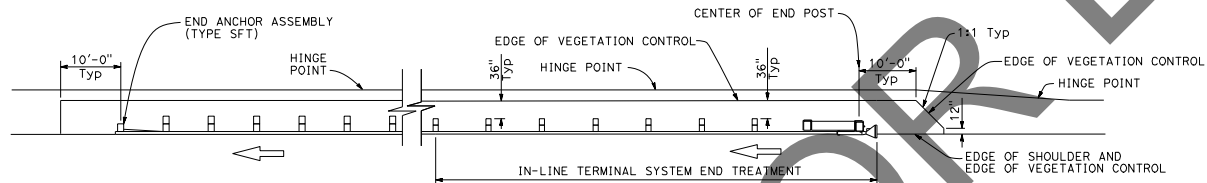

PLAN

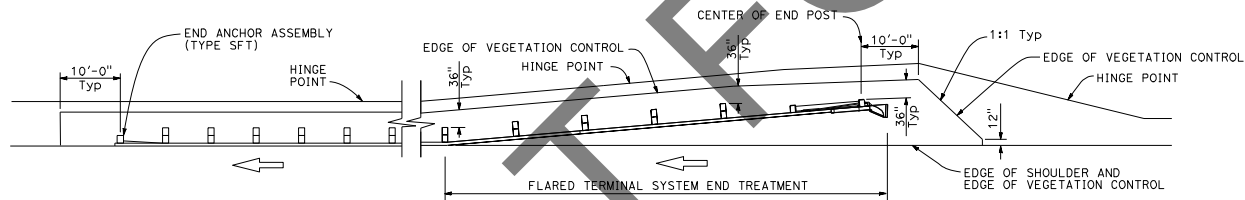

PLAN

NOT FOR BID

2018 STANDARD PLAN A77N6

STATE OF CALIFORNIA
 DEPARTMENT OF TRANSPORTATION
**MINOR CONCRETE VEGETATION CONTROL
 GUARDRAIL SYSTEM
 FOR TERMINAL SYSTEM END TREATMENTS**

NO SCALE

A77N6

DIST	COUNTY	ROUTE	POST MILES TOTAL PROJECT	SHEET NO.	TOTAL SHEETS

Randell D. Hiatt
REGISTERED CIVIL ENGINEER

May 31, 2018
PLANS APPROVAL DATE

THE STATE OF CALIFORNIA OR ITS OFFICERS OR AGENTS SHALL NOT BE RESPONSIBLE FOR THE ACCURACY OR COMPLETENESS OF SCANNED COPIES OF THIS PLAN SHEET.

REGISTERED PROFESSIONAL ENGINEER
No. C50200
Exp. 6-30-19
CIVIL
STATE OF CALIFORNIA

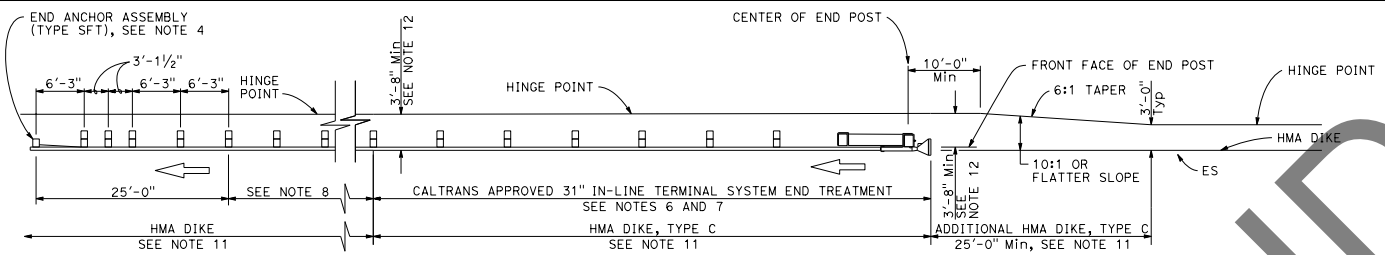

TYPE 11A LAYOUT

(Embankment MGS installation with 31" in-line end treatment at traffic approach end of railing)
See Note 5

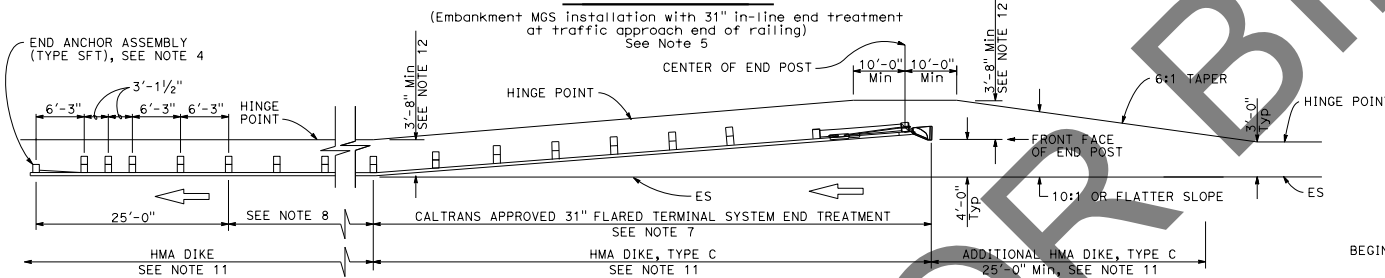

TYPE 11B LAYOUT

(Embankment MGS installation with 31" flared end treatment at traffic approach end of railing)
See Note 5

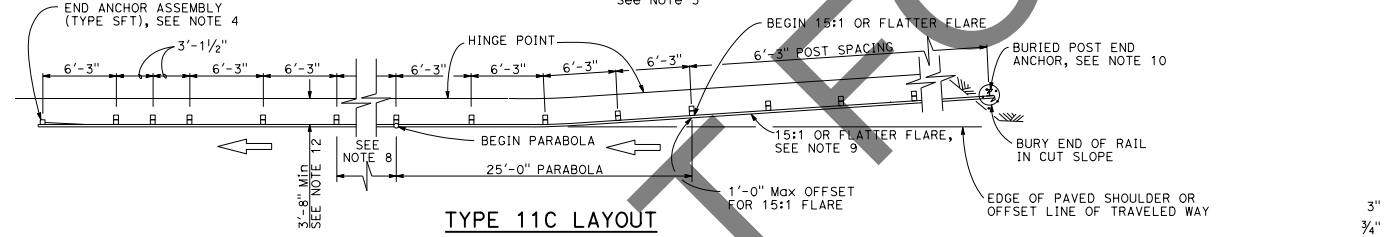

TYPE 11C LAYOUT

(Embankment MGS installation with buried end anchor treatment at traffic approach end of railing)
See Notes 5 and 11

- NOTES:**
- Line post, blocks and hardware to be used are shown on Standard Plans A77L1, A77L2, A77N1, A77N2 and A77M1.
 - MGS post spacing to be 6'-3" center to center, except as otherwise noted.
 - Except as noted, line posts are 6" x 8" x 6'-0" wood with 6" x 8" x 1'-2" wood blocks, W6 x 8.5 or W6 x 9 steel posts, 6'-0" in length, with 6" x 8" x 1'-2" notched wood blocks or recycled plastic blocks may be used for 6" x 8" x 6'-0" wood post with 6" x 8" x 1'-2" wood blocks where applicable and when specified.
 - For End Anchor Assembly (Type SFT) details, see Standard Plan A77S1.
 - Layout Types 11A, 11B or 11C are typically used where MGS is recommended to shield embankment slopes and a crashworthy end treatment is required for only one direction of traffic.
 - 31" in-line terminal system end treatments are used where site conditions will not accommodate a flared end treatment.
 - The type of 31" terminal system end treatment to be used will be shown on the Project Plans.
 - Dependent on site conditions (embankment height and side slope), construction of additional MGS (length equal to multiples of 12'-6" with 6'-3" post spacing) may be advisable.
 - The 15:1 or flatter flare used with buried end anchors is based on the edge of the paved shoulder or offset line of edge of the traveled way. The length of MGS within the 15:1 or flatter flare is based on site conditions and should be a length equal to multiples of 12'-6".
 - For details of the buried post end anchor used with Type 11C Layout, see Standard Plan A77T2.
 - Where placement of dike is required with MGS installations, see Standard Plan A77N4 for dike positioning details.
 - Use this offset for 8-inch block. For 12-inch block, use 4'-0" Min offset.

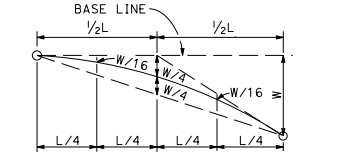

TYPICAL PARABOLIC LAYOUT

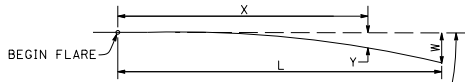

Y = OFFSET FROM BASE LINE
W = MAXIMUM OFFSET
X = DISTANCE ALONG BASE LINE
L = LENGTH OF FLARE

PARABOLIC FLARE OFFSETS

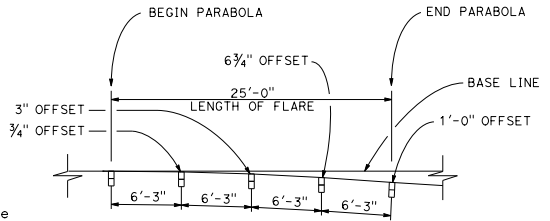

TYPICAL FLARE OFFSETS FOR 1 FOOT Max END OFFSET

STATE OF CALIFORNIA
DEPARTMENT OF TRANSPORTATION

**MIDWEST GUARDRAIL SYSTEM
TYPICAL LAYOUTS FOR
EMBANKMENTS**

NO SCALE

A77P1

2018 STANDARD PLAN A77P1

Return to Table of Contents

DIST	COUNTY	ROUTE	POST MILES TOTAL PROJECT	SHEET NO.	TOTAL SHEETS

Mark Ballentine
REGISTERED CIVIL ENGINEER
No. C64101
Exp. 09-30-22
STATE OF CALIFORNIA

April 15, 2022
PLANS APPROVAL DATE

THE STATE OF CALIFORNIA OR ITS OFFICERS OR AGENTS SHALL NOT BE RESPONSIBLE FOR THE ACCURACY OR COMPLETENESS OF SCANNED COPIES OF THIS PLAN SHEET.

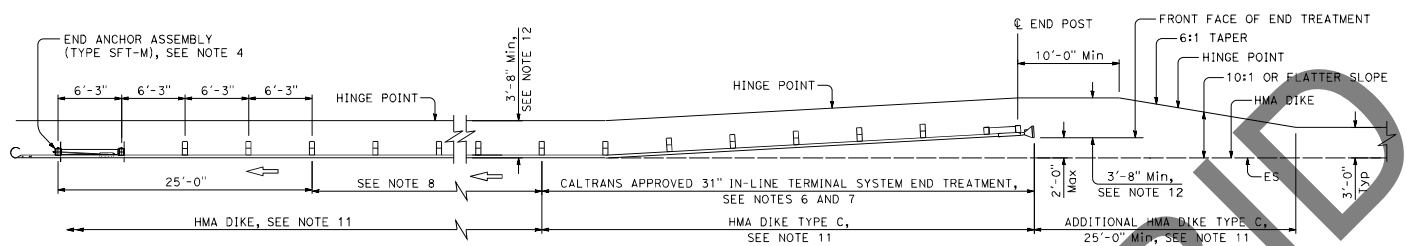

TYPE 11A LAYOUT

(Embankment MGS installation with 31" in-line end treatment at traffic approach end of railing), see Note 5.

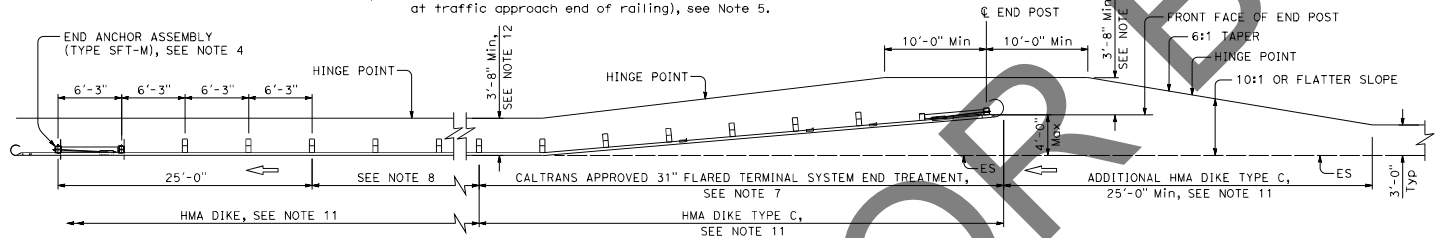

TYPE 11B LAYOUT

(Embankment MGS installation with 31" flared end treatment at traffic approach end of railing), see Note 5.

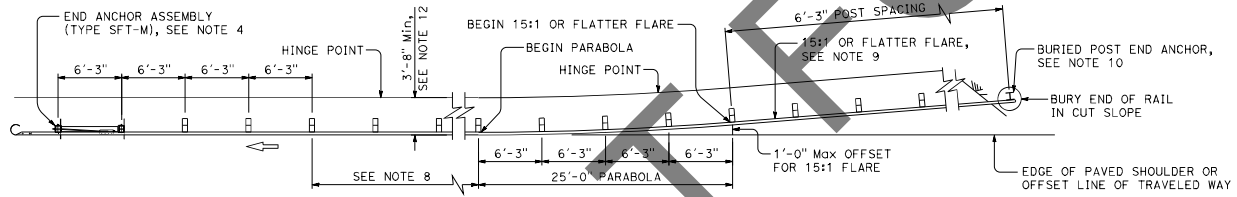

TYPE 11C LAYOUT

(Embankment MGS installation with buried end anchor treatment at traffic approach end of railing), see Notes 5 and 11.

NOTES:

- Line post, blocks and hardware to be used are shown on Revised Standard Plans RSP A77L1, RSP A77L2, RSP A77N1, RSP A77N2 and RSP A77M1.
- MGS post spacing to be 6'-3" center to center, except as otherwise noted.
- Except as noted, line posts are 6" x 8" x 6'-0" wood with 6" x 8" x 1'-2" wood blocks, W6 x 8.5 or W6 x 9 steel posts, 6'-0" in length, with 6" x 8" x 1'-2" notched wood blocks or recycled plastic blocks may be used for 6" x 8" x 6'-0" wood post with 6" x 8" x 1'-2" wood blocks where applicable and when specified.
- For End Anchor Assembly (Type SFT-M) details, see Revised Standard Plan RSP A77S1.
- Layout Types 11A, 11B or 11C are typically used where MGS is recommended to shield embankment slopes and a crashworthy end treatment is required for only one direction of traffic.
- 31" in-line terminal system end treatments are used where site conditions will not accommodate a flared end treatment.
- The type of 31" terminal system end treatment to be used will be shown on the Project Plans.
- Dependent on site conditions (embankment height and side slope), construction of additional MGS (length equal to multiples of 12'-6" with 6'-3" post spacing) may be advisable.
- The 15:1 or flatter flare used with buried end anchors is based on the edge of the paved shoulder or offset line of edge of the traveled way.
- For details of the buried post end anchor used with Type 11C Layout, see Revised Standard Plans RSP A77T2 and RSP A77T3.
- Where placement of dike is required with MGS installations, see Revised Standard Plan RSP A77N4 for dike positioning details.
- Use this offset for 8-inch block. For 12-inch block, use 4'-0" Min offset.

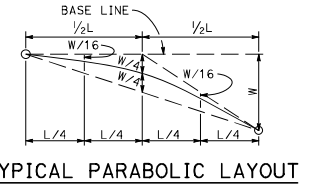

TYPICAL PARABOLIC LAYOUT

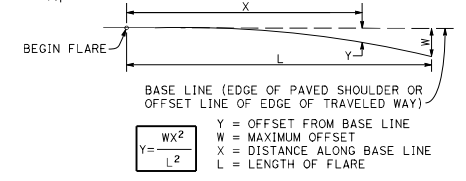

PARABOLIC FLARE OFFSETS

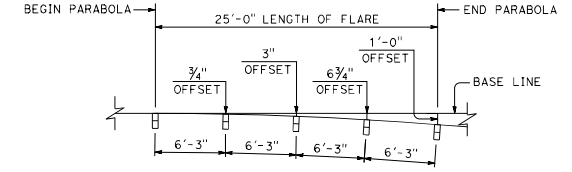

TYPICAL FLARE OFFSETS FOR 1 FOOT Max END OFFSET

STATE OF CALIFORNIA
DEPARTMENT OF TRANSPORTATION
**MIDWEST GUARDRAIL SYSTEM
TYPICAL LAYOUTS FOR
EMBANKMENTS**

NO SCALE
RSP A77P1 DATED APRIL 15, 2022 SUPERSEDES RSP A77P1 DATED OCTOBER 18, 2019 AND STANDARD PLAN A77P1 DATED MAY 31, 2018 - PAGE 80 OF THE STANDARD PLANS BOOK DATED 2018.
REVISED STANDARD PLAN RSP A77P1

2018 REVISED STANDARD PLAN RSP A77P1

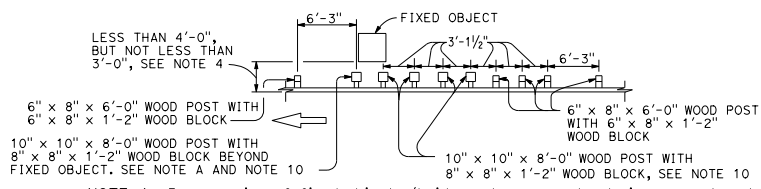

NOTE A: For a series of fixed objects (bridge columns, overhead sign supports, etc.) additional 10' x 10' x 8'-0' wood post with 8' x 8' x 1'-2' wood blocks at 3'-1/2' center to center spacing are to be used behind fixed object(s).

STRENGTHENED MIDWEST GUARDRAIL SYSTEM SECTIONS FOR FIXED OBJECT

Use strengthened MGS sections with layout Types 16D or 16E where minimum clearance between the face of the MGS and fixed object(s) is less than 4'-0", but not less than 3'-0". See Note 4.

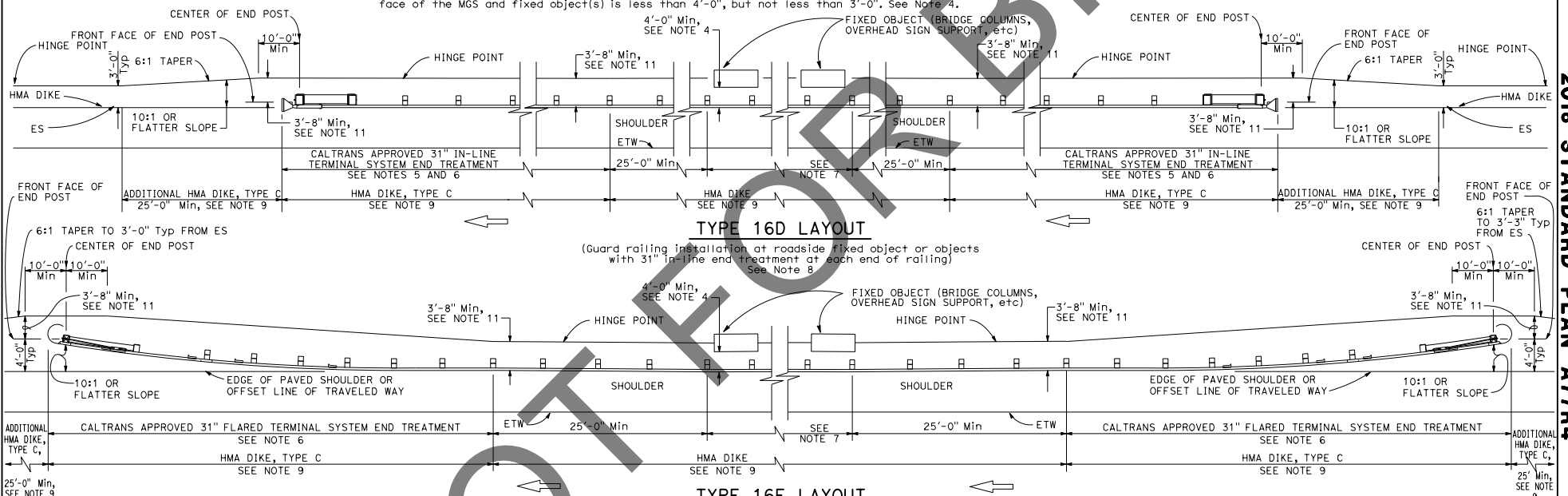

- NOTES:**
- Line post, blocks and hardware to be used are shown on Standard Plans A77L1, A77L2, A77N1, A77N2 and A77M1.
 - MGS post spacing to be 6'-3" center to center, except as otherwise noted.
 - Except as noted, line posts are 6" x 8" x 6'-0" wood with 6" x 8" x 1'-2" wood blocks. W6 x 8.5 or W6 x 9 steel posts, 6'-0" in length, with 6" x 8" x 1'-2" notched wood blocks or notched recycled plastic blocks may be used for 6" x 8" x 6'-0" wood line posts with 6" x 8" x 1'-2" wood blocks where applicable and when specified.
 - A 4'-0" minimum clearance is required between the face of the railing and the face of a fixed object located directly behind MGS sections with post spacing at 6'-3". Construct MGS as shown in the detail "Strengthened Midwest Guardrail System Sections for Fixed Object", on this plan, where the clearance between the face of the railing and the face of a fixed object is less than 4'-0", but not less than 3'-0". Where the clearance is less than 3'-0", a concrete wall or barrier should be constructed to shield the fixed object(s).
 - 31" in-line terminal system end treatments are used where site conditions will not accommodate a 31" flared end treatment.
 - The type of 31" terminal system to be used will be shown on the Project Plans.
 - As site conditions dictate, construct additional MGS to shield fixed object(s). Additional MGS length equal to multiples of 12'-6". Post spacing at 6'-3", except as specified in Note 4.
 - Layout Types 16D through 16L, shown on the A77R Series of Standard Plans, are typically used where MGS is recommended to shield roadside fixed object(s) and a crashworthy 31" end treatment is required for both directions of traffic.
 - Where placement of dike is required with MGS, see Standard Plan A77N4 for dike positioning details.
 - W6 x 15 steel post, 8'-0" in length, with 8" x 8" x 1'-2" notched wood block or notched recycled plastic block may be used in place of the 10" x 10" x 8'-0" wood post with 8" x 8" x 1'-2" wood block shown in the detail "Strengthened Midwest Guardrail System Sections for Fixed Object".
 - Use this offset for 8" block. For 12" block use minimum 4'-0" offset.

STATE OF CALIFORNIA
DEPARTMENT OF TRANSPORTATION
**MIDWEST GUARDRAIL SYSTEM
TYPICAL LAYOUTS FOR
ROADSIDE FIXED OBJECTS**
NO SCALE

A77R4

DIST	COUNTY	ROUTE	POST MILES TOTAL PROJECT	SHEET NO.	TOTAL SHEETS

Randell D. Hiatt
REGISTERED CIVIL ENGINEER

May 31, 2018
PLANS APPROVAL DATE

THE STATE OF CALIFORNIA OR ITS OFFICERS OR AGENTS SHALL NOT BE RESPONSIBLE FOR THE ACCURACY OR COMPLETENESS OF SCANNED COPIES OF THIS PLAN SHEET.

REGISTERED PROFESSIONAL ENGINEER
Randell D. Hiatt
No. C50200
Exp. 6-30-19
CIVIL
STATE OF CALIFORNIA

94

2018 STANDARD PLAN A77R4

[Return to Table of Contents](#)

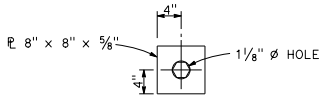

DETAIL "A"
CABLE CONNECTION
END PLATE

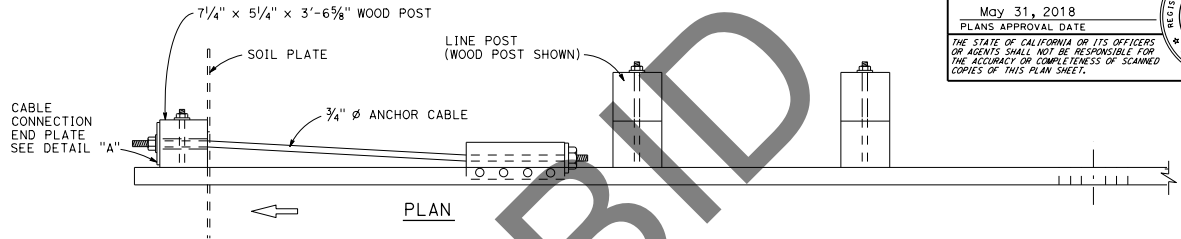

NOT FOR BIDDING

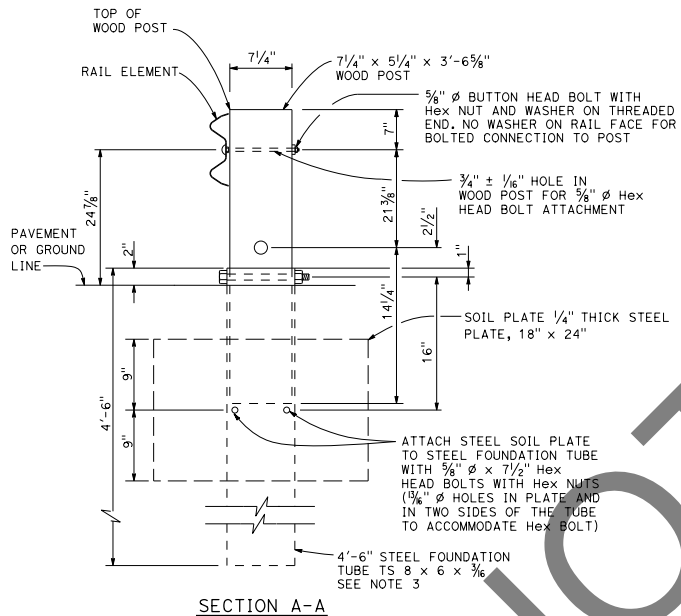

SECTION A-A

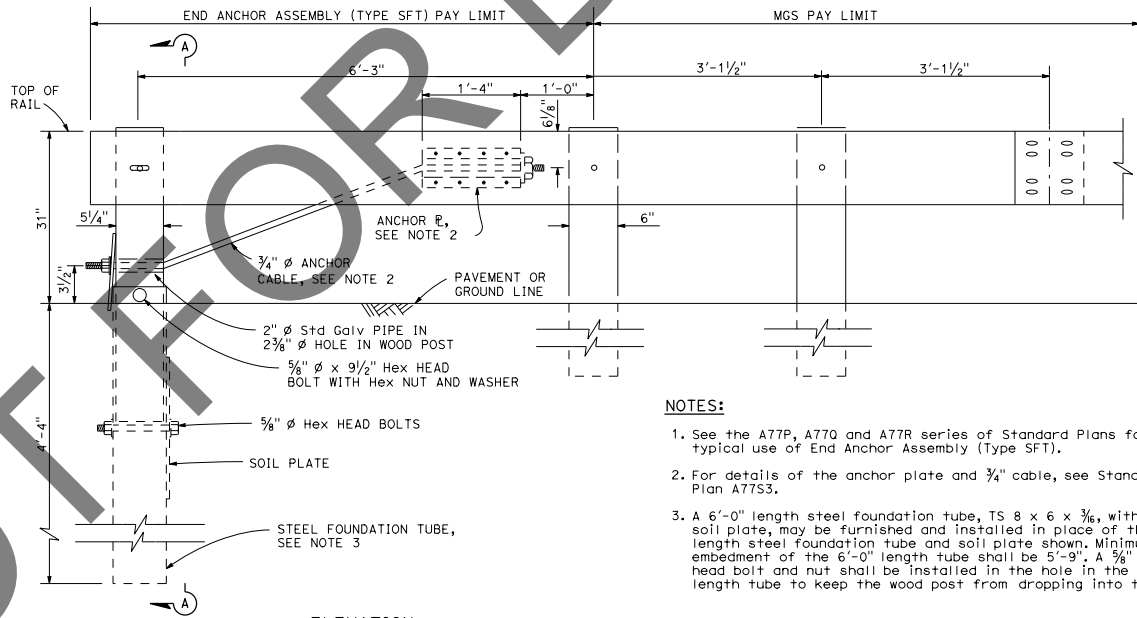

ELEVATION

END ANCHOR
ASSEMBLY (TYPE SFT)

See Note 1

NOTES:

1. See the A77P, A77Q and A77R series of Standard Plans for typical use of End Anchor Assembly (Type SFT).
2. For details of the anchor plate and 3/4" cable, see Standard Plan A77S3.
3. A 6'-0" length steel foundation tube, TS 8 x 6 x 3/8, without a soil plate, may be furnished and installed in place of the 4'-6" length steel foundation tube and soil plate shown. Minimum embedment of the 6'-0" length tube shall be 5'-9". A 3/8" diameter hex head bolt and nut shall be installed in the hole in the 6'-0" length tube to keep the wood post from dropping into the tube.

Dist	COUNTY	ROUTE	POST MILES TOTAL PROJECT	SHEET No.	TOTAL SHEETS

Randell D. Hiatt
REGISTERED CIVIL ENGINEER

May 31, 2018
PLANS APPROVAL DATE

THE STATE OF CALIFORNIA OR ITS OFFICERS OR AGENTS SHALL NOT BE RESPONSIBLE FOR THE ACCURACY OR COMPLETENESS OF SCANNED COPIES OF THIS PLAN SHEET.

REGISTERED PROFESSIONAL ENGINEER
Randell D. Hiatt
No. C60200
Exp. 6-30-19
CIVIL
STATE OF CALIFORNIA

STATE OF CALIFORNIA
DEPARTMENT OF TRANSPORTATION
MIDWEST GUARDRAIL SYSTEM
END ANCHOR ASSEMBLY
(TYPE SFT)

NO SCALE

A77S1

DIST	COUNTY	ROUTE	POST MILES TOTAL PROJECT	SHEET No.	TOTAL SHEETS

Mark Ballentine
REGISTERED CIVIL ENGINEER

April 15, 2022
PLANS APPROVAL DATE

THE STATE OF CALIFORNIA OR ITS OFFICERS OR AGENTS SHALL NOT BE RESPONSIBLE FOR THE ACCURACY OR COMPLETENESS OF SCANNED COPIES OF THIS PLAN SHEET.

REGISTERED PROFESSIONAL ENGINEER
No. CE4101
Exp. 09-30-22
CIVIL
STATE OF CALIFORNIA

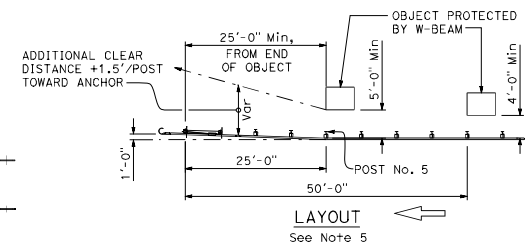
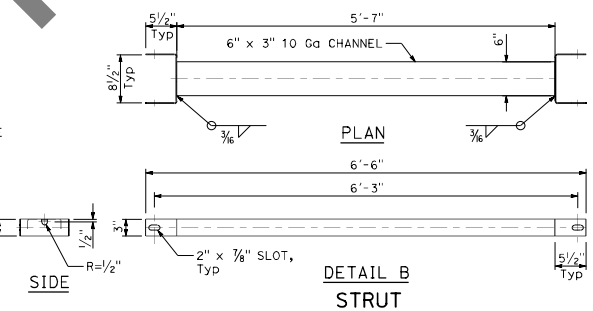
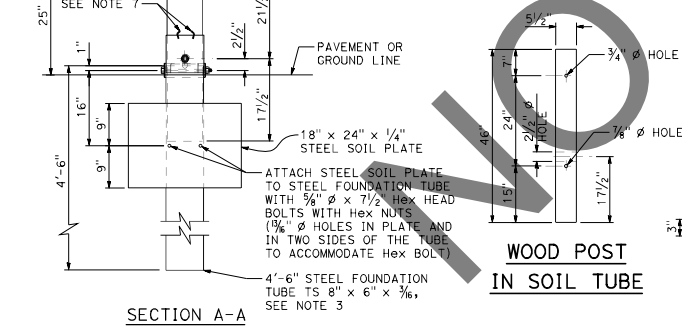
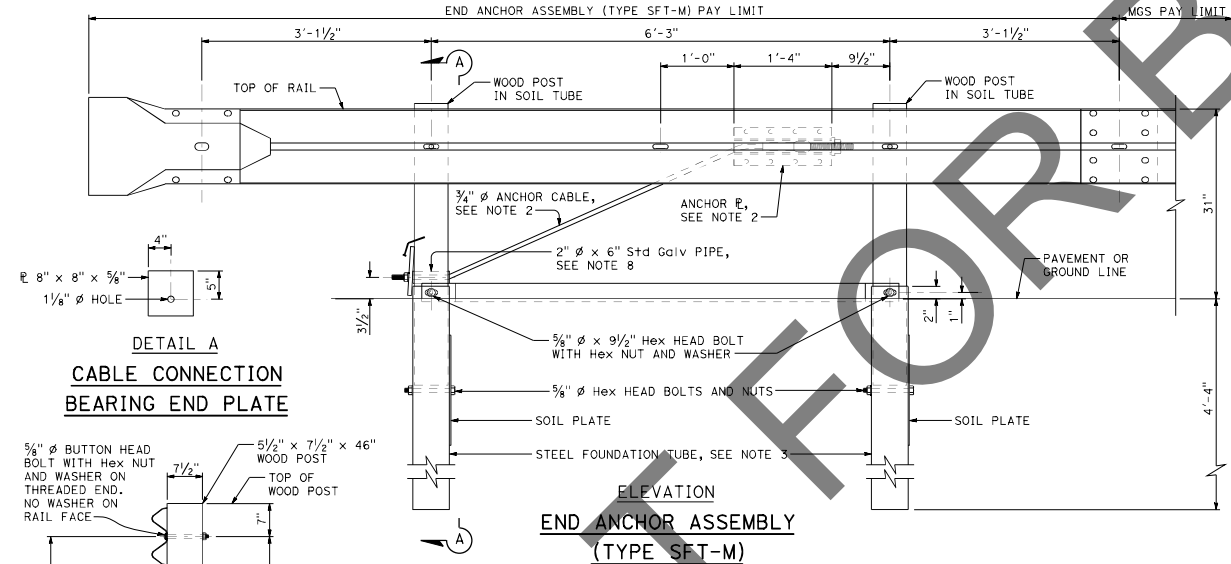
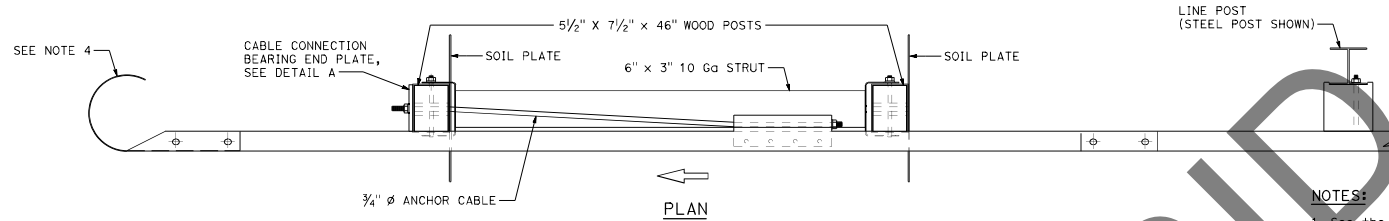

STATE OF CALIFORNIA
DEPARTMENT OF TRANSPORTATION

**MIDWEST GUARDRAIL SYSTEM
END ANCHOR ASSEMBLY
(TYPE SFT-M)**

NO SCALE

RSP A7751 DATED APRIL 15, 2022 SUPERSEDES STANDARD PLAN A7751
DATED MAY 31, 2018 - PAGE 99 OF THE STANDARD PLANS BOOK DATED 2018.

REVISED STANDARD PLAN RSP A7751

2018 REVISED STANDARD PLAN RSP A7751

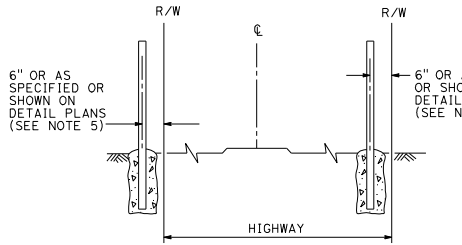

FENCE LOCATION

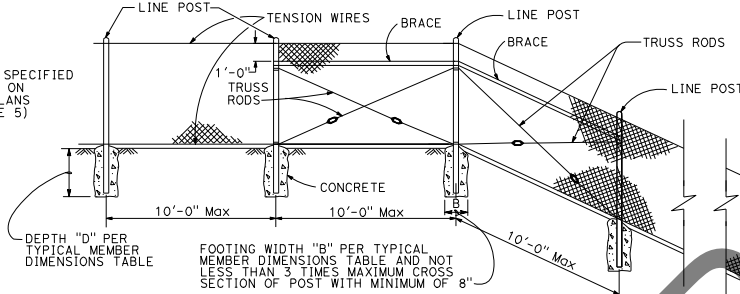

CHAIN LINK FENCE ON SHARP BREAK IN GRADE

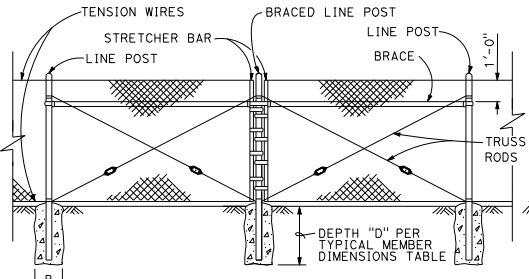
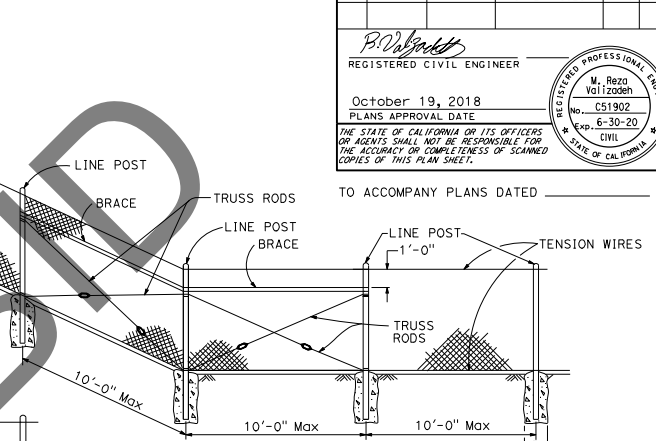

BRACED LINE POST INSTALLATION
Braced line post at intervals not exceeding 1000'

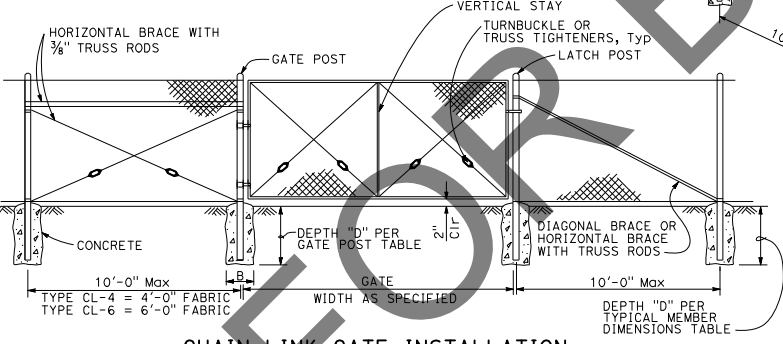

CHAIN LINK GATE INSTALLATION

Maximum Gate Width is 12'-0"
Vertical Stay is required in middle of gate greater than 8'-0" in width.

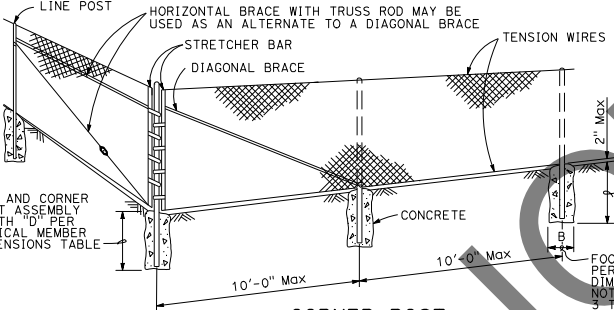

CORNER POST

- NOTES:**
- The table to the right shows minimum sized posts and braces complying with the specifications. Larger or heavier post and brace sizes may be used upon approval.
 - Sections shown in the tables must also comply with the strength requirements and other provisions of the specifications.
 - Other sections which comply with the strength requirements and other provisions of the specifications may be used upon approval.
 - Options exercised shall be uniform on any one project.
 - Offset to be 2'-0" at monument locations, measured at right angles to R/W lines. Taper to achieve offset to be at least 20'-0" long.
 - See Standard Plan A85B for Brace, Stretcher Bar, and Truss Tightener Details.

DIST	COUNTY	ROUTE	POST MILES TOTAL PROJECT	SHEET TOTAL SHEETS

P. Valizadeh
 REGISTERED CIVIL ENGINEER
 October 19, 2018
 PLANS APPROVAL DATE
 M. Reza Valizadeh
 No. C51902
 Exp. 6-30-20
 CIVIL
 STATE OF CALIFORNIA

THE STATE OF CALIFORNIA OR ITS OFFICERS OR AGENTS SHALL NOT BE RESPONSIBLE FOR THE ACCURACY OR COMPLETENESS OF SCANNED COPIES OF THIS PLAN SHEET.

GATE POST

FENCE HEIGHT (Max)	SLATTED	B (in)	D (ft)	ROUND PIPE		
				ROUND OD PIPE	GROUP 1A WEIGHT (lb/ft)	GROUP 1C WEIGHT (lb/ft)
5'-0"	NO	12"	2'-6"	3.50"	7.58	5.71
6'-0"	NO	12"	2'-6"	3.50"	7.58	5.71
8'-0"	NO	12"	3'-0"	3.50"	7.58	5.71
10'-0"	NO	14"	3'-6"	3.50"	7.58	5.71
5'-0"	YES	12"	3'-0"	4.00"	9.12	6.56
6'-0"	YES	14"	3'-6"	4.50"	10.80	-
8'-0"	YES	18"	3'-6"	5.56"	14.60	-
10'-0"	YES	20"	4'-0"	6.63"	19.00	-

Above post dimensions and weights are minimums. Larger sizes may be used upon approval.

TYPICAL MEMBER DIMENSIONS (See Notes)

FENCE HEIGHT (Max)	SLATTED	B (in)	D (ft)	LINE POSTS				BRACES					
				ROUND OD PIPE	GROUP 1A		GROUP 1C		ROUND OD PIPE	GROUP 1A		GROUP 1C	
					WEIGHT (lb/ft)	WEIGHT (lb/ft)	WEIGHT (lb/ft)	WEIGHT (lb/ft)		WEIGHT (lb/ft)	WEIGHT (lb/ft)	WEIGHT (lb/ft)	WEIGHT (lb/ft)
5'-0"	NO	8"	2'-6"	1.90"	2.72	2.28	1.875" x 1.625"	1.85	1.90"	2.72	2.28	1.625" x 1.250"	1.35
6'-0"	NO	10"	2'-6"	2.38"	3.66	3.12	1.875" x 1.625"	2.40	2.38"	3.66	3.12	1.625" x 1.250"	1.35
8'-0"	NO	12"	3'-0"	2.88"	5.80	4.64	3,250" x 2,500"	4.50	2.38"	3.66	3.12	1.625" x 1,250"	1.35
10'-0"	NO	14"	3'-6"	3.50"	7.58	5.71	3,250" x 2,500"	4.50	2.88"	5.80	4.64	1.625" x 1,250"	1.35
5'-0"	YES	12"	3'-0"	4.00"	9.12	6.56	N/A	-	2.38"	3.66	3.12	N/A	-
6'-0"	YES	14"	3'-0"	4.50"	10.80	-	N/A	-	2.38"	3.66	3.12	N/A	-
8'-0"	YES	18"	3'-6"	5.56"	14.60	-	N/A	-	2.38"	3.66	3.12	N/A	-
10'-0"	YES	20"	4'-0"	6.63"	19.00	-	N/A	-	2.88"	5.80	4.64	N/A	-

STATE OF CALIFORNIA
 DEPARTMENT OF TRANSPORTATION
CHAIN LINK FENCE
 NO SCALE

RSP A85 DATED OCTOBER 19, 2018 SUPERSEDES STANDARD PLAN A85
DATED MAY 31, 2018 - PAGE 140 OF THE STANDARD PLANS BOOK DATED 2018.

REVISED STANDARD PLAN RSP A85

2018 REVISED STANDARD PLAN RSP A85

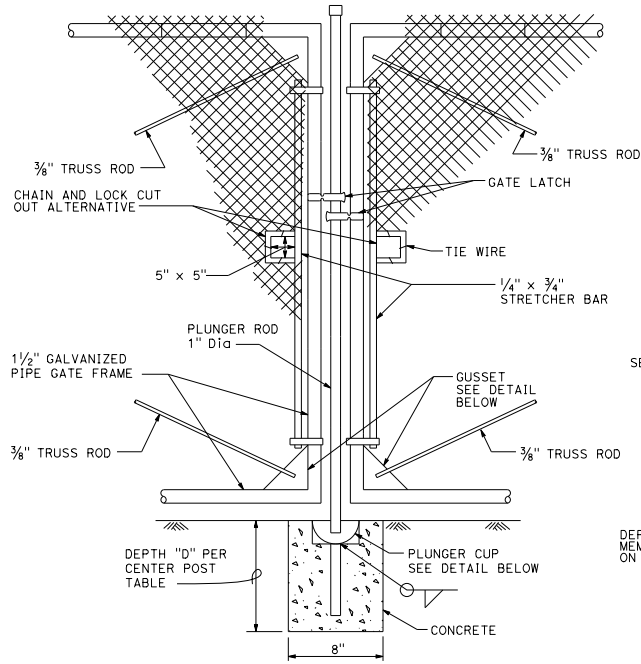

**DOUBLE GATE
REMOVABLE CENTER POST**

Each gate maximum width is 12'-0"

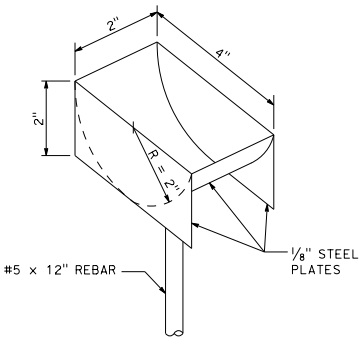

PLUNGER CUP DETAIL

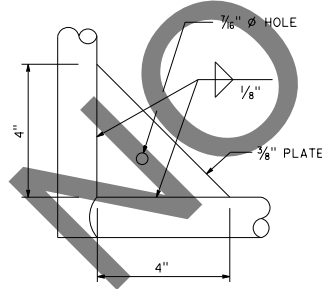

GUSSET DETAIL

CENTER POST		
FENCE HEIGHT (Max)	SLATTED	D
ALL HEIGHTS	NO	1'-6"
5'-0"	YES	3'-0"
6'-0"	YES	3'-0"
8'-0"	YES	3'-6"
10'-0"	YES	4'-0"

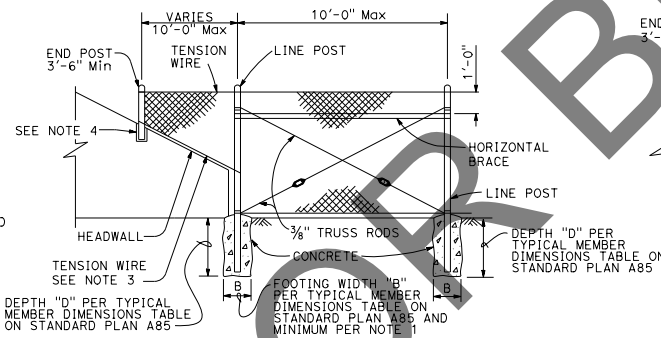

METHOD OF TYING FENCE TO HEADWALL

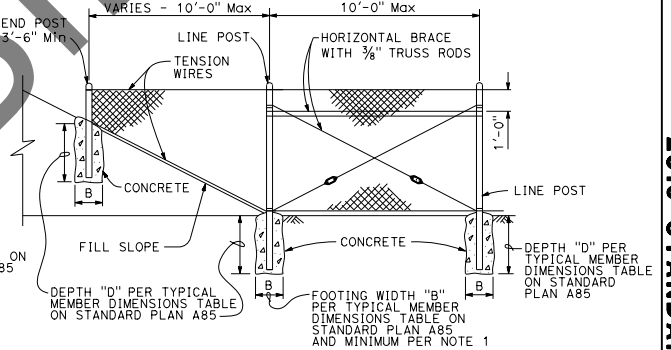

METHOD OF ERECTING FENCE FOR FILL SLOPE

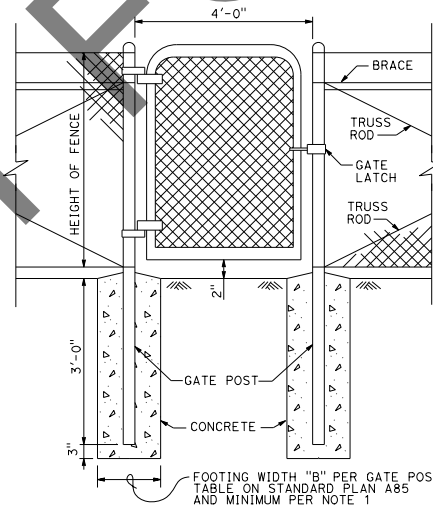

WALK GATE

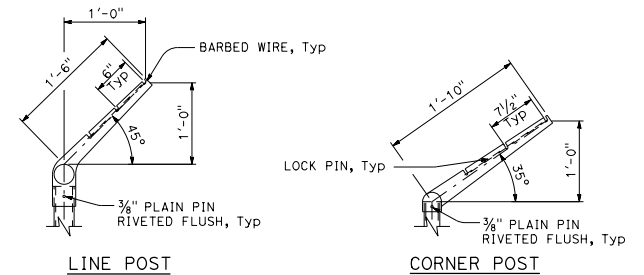

BARBED WIRE POST TOP

STATE OF CALIFORNIA
DEPARTMENT OF TRANSPORTATION

CHAIN LINK FENCE DETAILS

NO SCALE

A85A

NOTES:

1. B is not less than 3 times maximum cross section of post with minimum of 8".
2. See Standard Plan A85 for Chain Link Fencing dimensions.
3. See Detail A on Standard Plan A86B for connection at headwall.
4. See Detail D on Standard Plan A86B for connection at headwall.

D16+	COUNTY	ROUTE	POST MILES TOTAL PROJECT	SHEET TOTAL No. SHEETS

P. Valizadeh
REGISTERED CIVIL ENGINEER

May 31, 2018
PLANS APPROVAL DATE

M. Reza Valizadeh
No. C51902
EXP. 6-30-18
CIVIL ENGINEER PROFESSIONAL ENGINEER STATE OF CALIFORNIA

THE STATE OF CALIFORNIA OR ITS OFFICERS OR AGENTS SHALL NOT BE RESPONSIBLE FOR THE ACCURACY OR COMPLETENESS OF SCANNED COPIES OF THIS PLAN SHEET.