

LEFT EDGELINES

(DIVIDED HIGHWAYS)

DETAIL 24

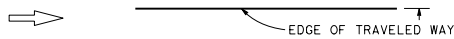

DETAIL 25

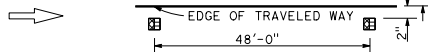

DETAIL 25A

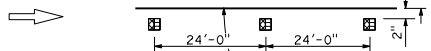

DETAIL 26

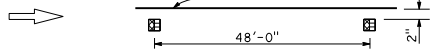

DETAIL 27

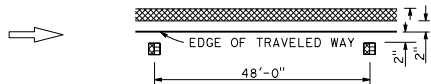

RIGHT EDGELINES

DETAIL 27A

DETAIL 27A DELETED

DETAIL 27B

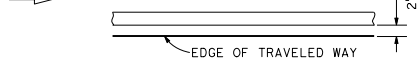

RIGHT EDGELINE EXTENSION THROUGH INTERSECTIONS

DETAIL 27C

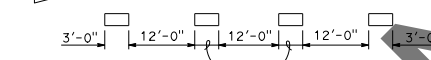

MEDIAN ISLANDS

DETAIL 28



DETAIL 29



DETAIL 29



DETAIL 30

DETAIL 30 DELETED

TWO-WAY LEFT TURN LANES

DETAIL 31

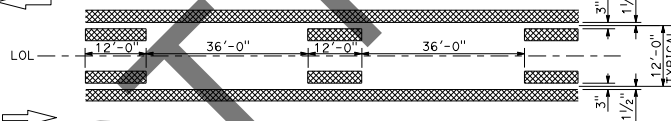

DETAIL 32

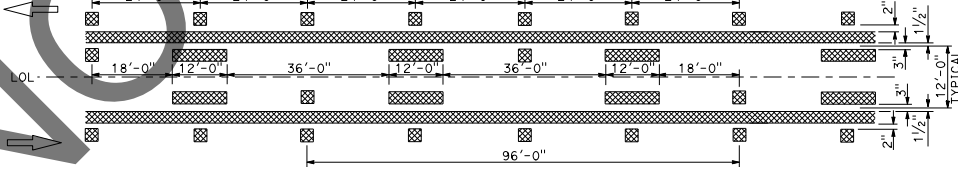

DETAIL 33

DETAIL 33 DELETED

LEGEND

MARKERS

- TYPE D TWO-WAY YELLOW RETROREFLECTIVE
- TYPE H ONE-WAY YELLOW RETROREFLECTIVE
- TYPE RY RED-YELLOW RETROREFLECTIVE

LINES

- 6" WHITE
- 6" YELLOW

INTERSECTION TREATMENTS

DETAIL 34

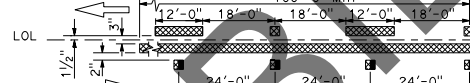

DETAIL 34A

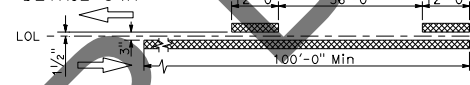

DETAIL 35

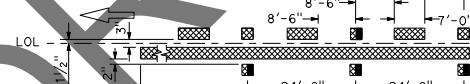

DETAIL 35A

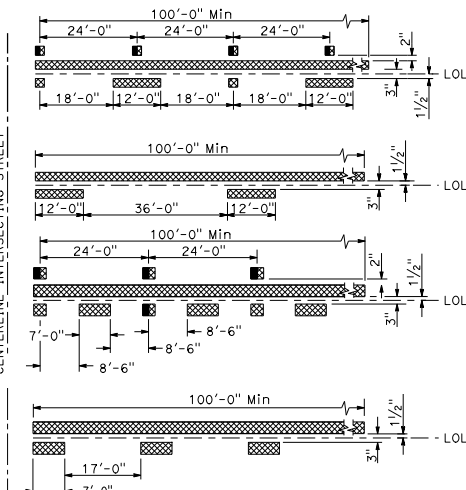
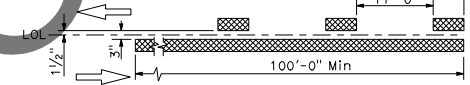

MARKER DETAILS

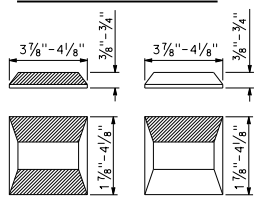

TYPE RY AND TYPE D TYPE H

RETROREFLECTIVE FACE

STATE OF CALIFORNIA DEPARTMENT OF TRANSPORTATION

PAVEMENT MARKERS AND TRAFFIC LINES TYPICAL DETAILS

NO SCALE

A20B

D18+	COUNTY	ROUTE	POST MILES TOTAL PROJECT	SHEET NO.	TOTAL SHEETS

Atifa Ferouzi
REGISTERED CIVIL ENGINEER

PLANS APPROVAL DATE
Mcy 31, 2018
No. C80402
EXP. 3-31-19
CIVIL

THE STATE OF CALIFORNIA OR ITS OFFICERS OR AGENTS SHALL NOT BE RESPONSIBLE FOR THE ACCURACY OR COMPLETENESS OF SCANNED COPIES OF THIS PLAN SHEET.

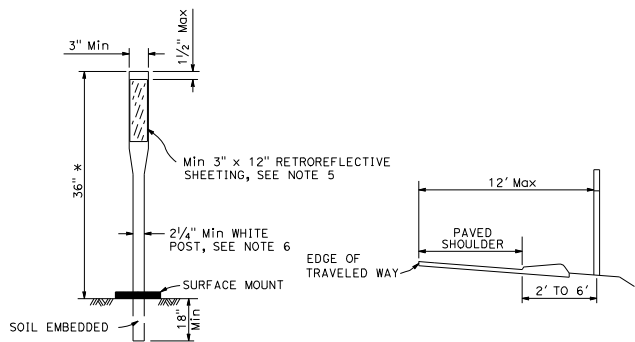

* 36" Min where speeds are 40 miles/h or less.
CHANNELIZERS

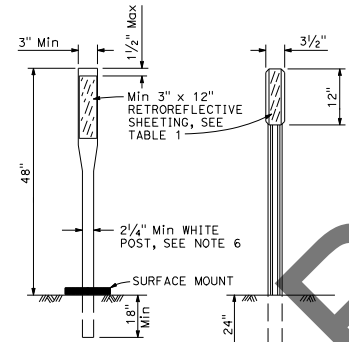

CLASS 1 FLEXIBLE POST
CLASS 2 METAL POST
 See Note 4
DELINEATORS

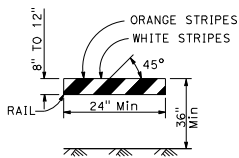

TYPE I BARRICADE
 See Note A

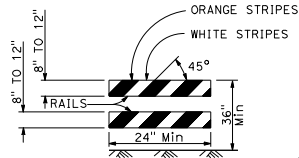

TYPE II BARRICADE

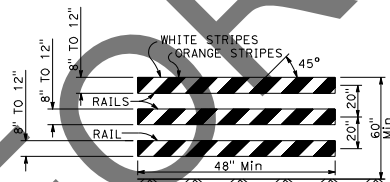

TYPE III BARRICADE

BARRICADES (See Note 3)

Only face of rails shown, barricade construction materials and supports as specified in the specifications.

BARRICADE	TYPE I	TYPE II	TYPE III
WIDTH OF RAIL	8" Min - 12" Max *	8" Min - 12" Max *	8" Min - 12" Max *
LENGTH OF RAIL	24" Min	24" Min	48" Min
WIDTH OF STRIPES **	6"	6"	6"
HEIGHT	36" Min	36" Min	60" Min
NUMBER OF RETROREFLECTIVE RAIL FACES	2 (ONE EACH DIRECTION)	4 (TWO EACH DIRECTION)	3 IF FACING TRAFFIC IN ONE DIRECTION 6 IF FACING TRAFFIC IN TWO DIRECTION

* For the wooden option dimensions are nominal lumber dimensions.
 ** For rails less than 36" long, 4" wide stripes shall be used.

NOTE A:

Barricades to have a minimum of 270 square inches of retroreflective area facing traffic when used on freeways, expressways, and other high speed highways.

Dist	COUNTY	ROUTE	POST MILES TOTAL PROJECT	SHEET TOTAL No. SHEETS

Atifa Ferouz
 REGISTERED CIVIL ENGINEER
 No. C80402
 May 31, 2018
 PLANS APPROVAL DATE
 THE STATE OF CALIFORNIA OR ITS OFFICERS OR AGENTS SHALL NOT BE RESPONSIBLE FOR THE ACCURACY OR COMPLETENESS OF SCANNED COPIES OF THIS PLAN SHEET.

TYPE	RETROREFLECTIVE SHEETING	
	FRONT	BACK
E	WHITE	WHITE (SEE NOTE 1)
F	WHITE	NONE
G	YELLOW	NONE
J	RED	NONE

NOTES:

- The retroreflective sheeting used on the back of delineator shall be a minimum size of 3" x 3".
- The type of delineator to be installed will be designated on the plans.
- All barricade stripes shall be retroreflective and sloped downward in the direction of the opened traffic lane.
- See Standard Plan A73B for Metal Post Details.
- Unless shown otherwise on the plans, or as directed by the Engineer, the color of the retroreflective sheeting for permanent channelizers shall conform to the color of the pavement markings it supplements.
- Except, Class 1 (Flexible Post) temporary delineators and temporary channelizers in work zones shall be orange post with white retroreflective sheeting.

STATE OF CALIFORNIA
 DEPARTMENT OF TRANSPORTATION
**DELINEATORS, CHANNELIZERS
 AND BARRICADES**

NO SCALE

A73C

Dist	COUNTY	ROUTE	POST MILES TOTAL PROJECT	SHEET TOTAL No. SHEETS
<i>Randell D. Hiatt</i> REGISTERED CIVIL ENGINEER				
May 31, 2018 PLANS APPROVAL DATE				
<small>THE STATE OF CALIFORNIA OR ITS OFFICERS OR AGENTS SHALL NOT BE RESPONSIBLE FOR THE ACCURACY OR COMPLETENESS OF SCANNED COPIES OF THIS PLAN SHEET.</small>				

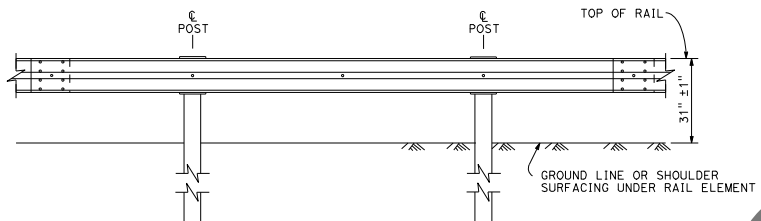
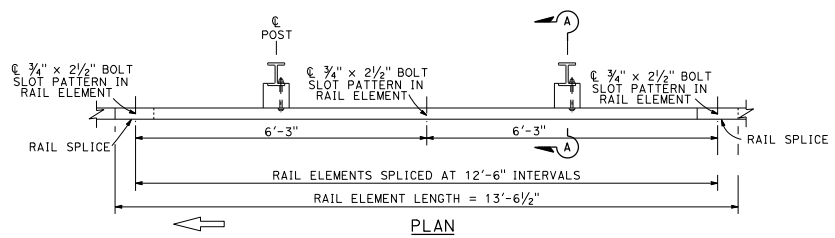

**MIDWEST GUARDRAIL SYSTEM WITH STEEL POSTS
AND NOTCHED WOOD OR NOTCHED RECYCLED PLASTIC BLOCKS**

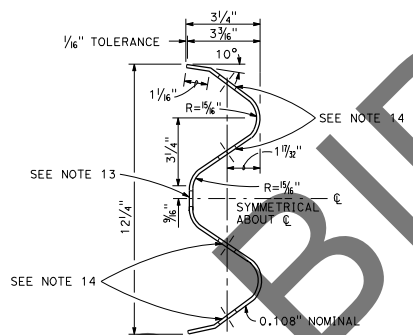

**SECTION THRU
RAIL ELEMENT**

NOTES:

1. For details of wood post installations, see Standard Plan A77L1.
2. For details of standard hardware used to construct MGS, see Standard Plan A77M1.
3. For details of steel posts and notched wood blocks used to construct MGS, see Standard Plan A77N2.
4. For additional installation details, see Standard Plan A77N3.
5. MGS post spacing to be 6'-3" center to center, except as otherwise noted.
6. For MGS typical layouts, see the A77P, A77Q and A77R Series of Standard Plans.
7. If railing is connected to terminal system end treatment, use 31" height terminal system end treatment.
8. For MGS end anchor details, see Standard Plans A77S1 and A77T2.
9. For details of MGS transition to bridge railing, see Standard Plan A77U4.
10. For additional details of MGS connection to bridge railings, see Standard Plans A77U1, A77U2 and A77V1.
11. For dike positioning and MGS delineation details, see Standard Plan A77N4.
12. Notched face of block faces steel post.
13. Slotted hole for bolted connection of rail element to block and post.
14. Slotted holes for splice bolts to overlap ends of rail element.
15. 6" x 12" x 1'-2" block must be used with 6" dike.

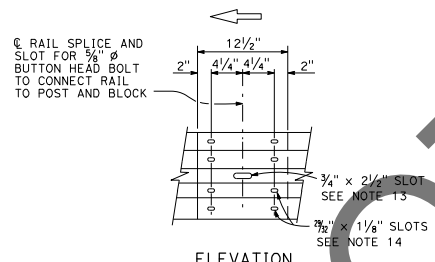

**ELEVATION
RAIL ELEMENT SPLICE DETAIL**

- a) Connect the overlapped end of the rail elements with $\frac{5}{8}$ " ϕ x $1\frac{1}{8}$ " button head oval shoulder splice bolts inserted into the $\frac{3}{4}$ " x $1\frac{1}{4}$ " slots and bolted together with $\frac{3}{8}$ " ϕ recessed hex nuts. Recess of hex nut points toward rail element. A total of 8 bolts and nuts are to be used at each rail splice connection.
- b) The ends of the rail elements are to be overlapped in the direction of traffic (see details).
- c) Where end cap is to be attached to the end of a rail element, a total of 4 of the above described splice bolts and nuts are to be used.

$\frac{5}{8}$ " ϕ BUTTON HEAD BOLT WITH HEX NUT, ATTACH RAIL ELEMENT TO WOOD BLOCK AND STEEL POST WITH BOLT ON TRAFFIC APPROACH SIDE OF POST WEB. NO WASHER ON RAIL FACE FOR BOLTED CONNECTION TO LINE POST

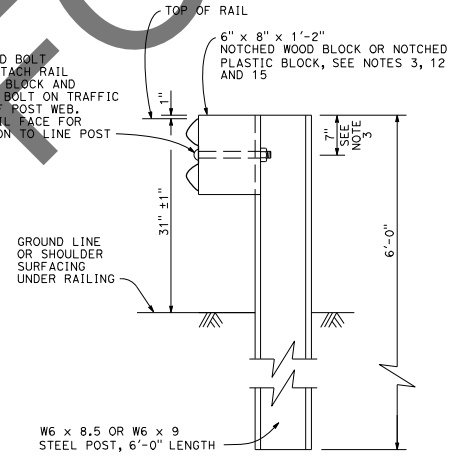

**SECTION A-A
TYPICAL STEEL LINE
POST INSTALLATION**

See Note 4

STATE OF CALIFORNIA
DEPARTMENT OF TRANSPORTATION
**MIDWEST GUARDRAIL SYSTEM
STANDARD RAILING SECTION
(STEEL POST WITH NOTCHED
WOOD OR NOTCHED
RECYCLED PLASTIC BLOCK)**

NO SCALE

A77L2

2018 STANDARD PLAN A77L2

DIST	COUNTY	ROUTE	POST MILES TOTAL PROJECT	SHEET NO.	TOTAL SHEETS

Randell D. Hiatt
REGISTERED CIVIL ENGINEER

April 19, 2019
PLANS APPROVAL DATE

THE STATE OF CALIFORNIA OR ITS OFFICERS OR AGENTS SHALL NOT BE RESPONSIBLE FOR THE ACCURACY OR COMPLETENESS OF SCANNED COPIES OF THIS PLAN SHEET.

NO. C50200
EXP. 6-30-19
CIVIL
REGISTERED PROFESSIONAL ENGINEER
STATE OF CALIFORNIA

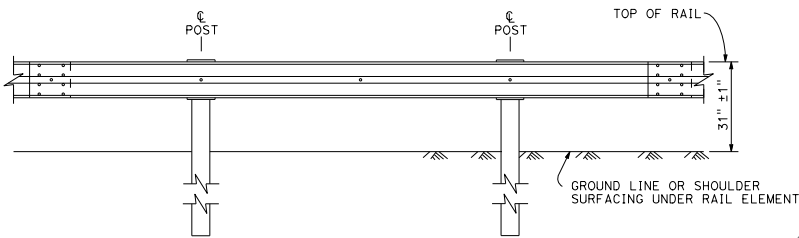
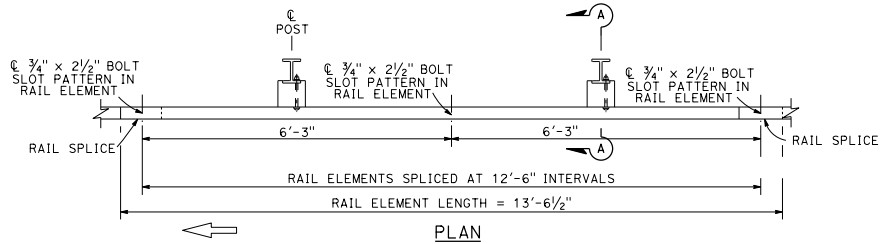

ELEVATION

**MIDWEST GUARDRAIL SYSTEM WITH STEEL POSTS
AND NOTCHED WOOD OR NOTCHED RECYCLED PLASTIC BLOCKS**

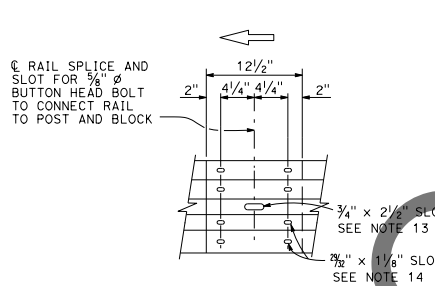

ELEVATION
RAIL ELEMENT SPLICE DETAIL

- Connect the overlapped end of the rail elements with $\frac{3}{8}$ " ϕ x $1\frac{1}{8}$ " button head oval shoulder splice bolts inserted into the $\frac{3}{4}$ " x $1\frac{1}{8}$ " slots and bolted together with $\frac{3}{8}$ " ϕ recessed hex nuts. Recess of hex nut points toward rail element. A total of 4 bolts and nuts are to be used at each rail splice connection.
- The ends of the rail elements are to be overlapped in the direction of traffic (see details).
- Where end cap is to be attached to the end of a rail element, a total of 4 of the above described splice bolts and nuts are to be used.

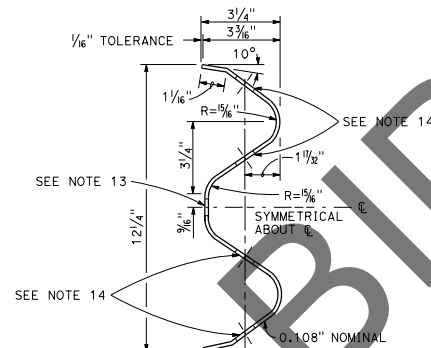

SECTION THRU
RAIL ELEMENT

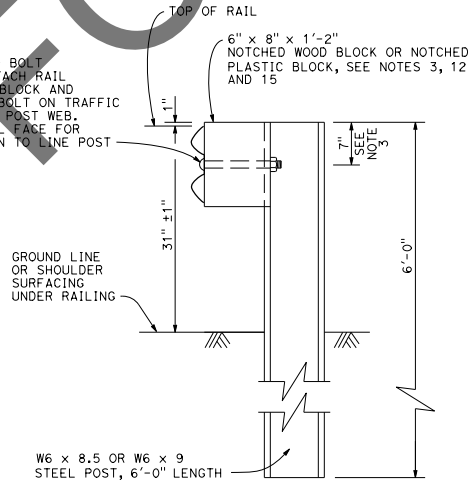

SECTION A-A
TYPICAL STEEL LINE
POST INSTALLATION

See Note 4

NOTES:

- For details of steel post installations, see Revised Standard Plan RSP A77L1.
- For details of standard hardware used to construct MGS, see Standard Plan A77M1.
- For details of steel posts and notched wood blocks used to construct MGS, see Standard Plan A77N2. For additional installation details, see Standard Plan A77N3.
- MGS post spacing to be 6'-3" center to center, except as otherwise noted.
- For MGS typical layouts, see the A77P, A77Q and A77R Series of Standard Plans.
- If railing is connected to terminal system end treatment, use 31" height terminal system end treatment.
- For MGS end anchor details, see Standard Plans A77S1 and A77T2.
- For details of MGS transition to bridge railing, see Revised Standard Plan RSP A77U4.
- For additional details of MGS connection to bridge railings, see Standard Plans A77U1, A77U2 and A77V1.
- For dike positioning and MGS delineation details, see Revised Standard Plan RSP A77N4.
- Notched face of block faces steel post.
- Slotted hole for bolted connection of rail element to block and post.
- Slotted holes for splice bolts to overlap ends of rail element.
- 6" x 12" x 1'-2" block must be used with 6" dike.
- Install posts in soil.

STATE OF CALIFORNIA
DEPARTMENT OF TRANSPORTATION

**MIDWEST GUARDRAIL SYSTEM
STANDARD RAILING SECTION
(STEEL POST WITH NOTCHED
WOOD OR NOTCHED
RECYCLED PLASTIC BLOCK)**

NO SCALE

RSP A77L2 DATED APRIL 19, 2019 SUPERSEDES STANDARD PLAN A77L2
DATED MAY 31, 2018 - PAGE 58 OF THE STANDARD PLANS BOOK DATED 2018.

REVISED STANDARD PLAN RSP A77L2

2018 REVISED STANDARD PLAN RSP A77L2

DIST	COUNTY	ROUTE	POST MILES TOTAL PROJECT	SHEET No.	TOTAL SHEETS
<i>Randell D. Hiatt</i> REGISTERED CIVIL ENGINEER					
May 31, 2018 PLANS APPROVAL DATE					
No. C50200 Exp. 6-30-19 CIVIL STATE OF CALIFORNIA					
<small>THE STATE OF CALIFORNIA OR ITS OFFICERS OR AGENTS SHALL NOT BE RESPONSIBLE FOR THE ACCURACY OR COMPLETENESS OF SCANNED COPIES OF THIS PLAN SHEET.</small>					

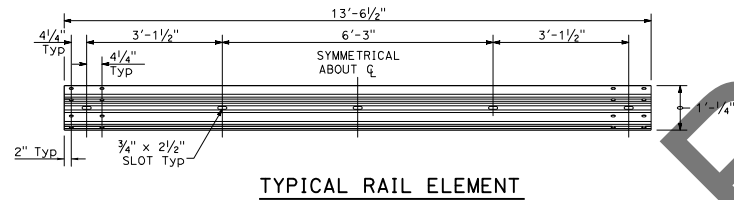

TYPICAL RAIL ELEMENT

NOTE:

1. Slotted holes for splice bolts to overlap ends of rail element.

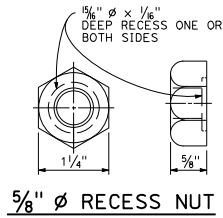

5/8" ϕ RECESS NUT

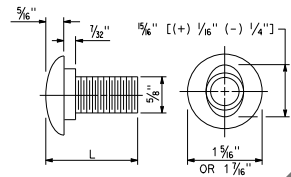

5/8" ϕ BUTTON HEAD BOLT

BUTTON HEAD BOLT

L	THREAD LENGTH
1 3/8"	FULL THREAD LENGTH
2"	FULL THREAD LENGTH
10"	4" Min THREAD LENGTH
18"	4" Min THREAD LENGTH
20"	4" Min THREAD LENGTH
22"	4" Min THREAD LENGTH
26"	4" Min THREAD LENGTH
36"	4" Min THREAD LENGTH
** 2 3/4"	2" Min THREAD LENGTH
** 19"	4" Min THREAD LENGTH

** For nested rail applications.

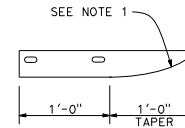

SEE NOTE 1

PLAN

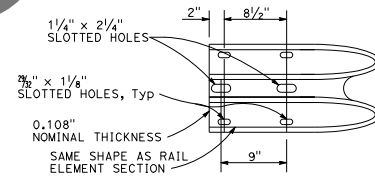

ELEVATION

**END CAP
(TYPE A)**

STATE OF CALIFORNIA
DEPARTMENT OF TRANSPORTATION
**MIDWEST GUARDRAIL SYSTEM
STANDARD HARDWARE**

NO SCALE

A77M1

2018 STANDARD PLAN A77M1

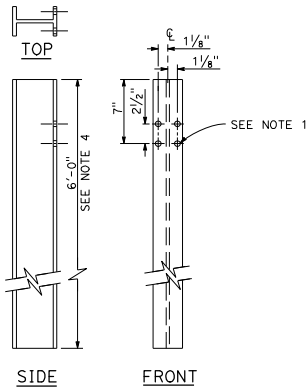

W6 x 9 OR W6 x 8.5
STEEL POST
See Note 4

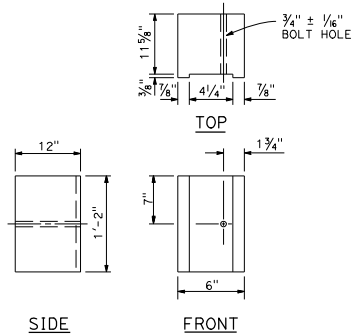

6" x 12"
NOTCHED WOOD BLOCK
See Notes 2, 3 and 7

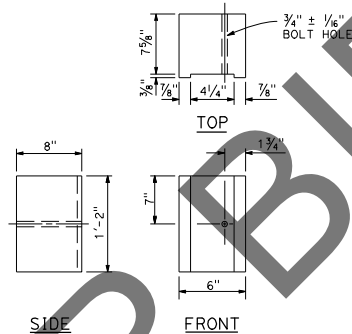

6" x 8"
NOTCHED WOOD BLOCK
Only for use with metal beam guard railing. See Note 5

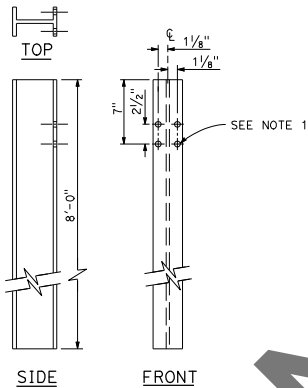

W6 x 9 OR W6 x 8.5
STEEL POST
See Note 6

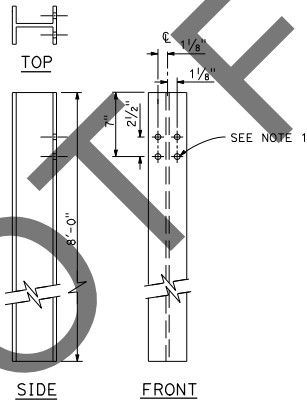

W6 x 15
STEEL POST

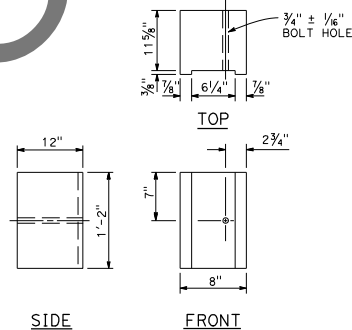

8" x 12"
NOTCHED WOOD BLOCK
See Notes 2, 3 and 7

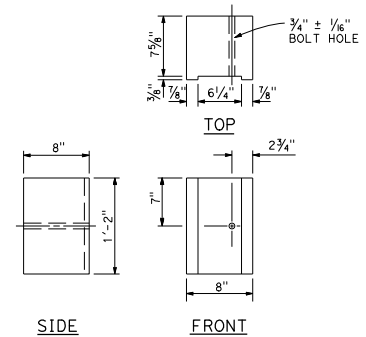

8" x 8"
NOTCHED WOOD BLOCK
Only for use with metal beam guard railing. See Note 5

DIST	COUNTY	ROUTE	POST MILES TOTAL PROJECT	SHEET NO.	TOTAL SHEETS

Randell D. Hiett
REGISTERED CIVIL ENGINEER

May 31, 2018
PLANS APPROVAL DATE

NO. C50200
Exp. 6-30-19
CIVIL
STATE OF CALIFORNIA

REGISTERED PROFESSIONAL ENGINEER

THE STATE OF CALIFORNIA OR ITS OFFICERS OR AGENTS SHALL NOT BE RESPONSIBLE FOR THE ACCURACY OR COMPLETENESS OF SCANNED COPIES OF THIS PLAN SHEET.

NOTES:

- All holes in steel post shall be 5/16" Dia maximum.
- Dimensions shown for wood block are nominal.
- Notched face of block faces steel post.
- 6'-0" length posts to be used for typical roadway installation. See Standard Plan A77N3.
- See Standard Plan A77L3 for use of 6" x 8" and 8" x 8" notched wood blocks.
- This post and 8" x 12" block combination to be used for line post sections of MGS on narrow roadways and where strengthened line post sections of MGS are warranted to shield fixed objects.
- 6" x 12" notched wood block and 8" x 12" notched wood block must be used with 6" dike.

STATE OF CALIFORNIA
DEPARTMENT OF TRANSPORTATION
MIDWEST GUARDRAIL SYSTEM
STEEL POST AND
NOTCHED WOOD BLOCK DETAILS
NO SCALE

A77N2

DIST	COUNTY	ROUTE	POST MILES TOTAL PROJECT	SHEET NO.	TOTAL SHEETS

Randell D. Hiatt
 REGISTERED CIVIL ENGINEER
 May 31, 2018
 PLANS APPROVAL DATE
 No. C60200
 Exp. 6-30-19
 CIVIL
 STATE OF CALIFORNIA

NOTES:

1. When necessary to place dike more than 7" in front of face of MGS, only Type C dike may be used. For dike details, see Standard Plan A87B.
2. For standard railing post embedment, see Standard Plan A77N3.
3. MGS delineation to be used where shown on the Project Plans.
4. When dike or curb is placed under MGS, the maximum height of the dike or curb shall be 6". Mountable dike should not be used. For dike and curb details, see Standard Plans A87A and A87B.
5. For details of typical distance between the face of rail and hinge point, see Standard Plan A77N3.
6. For steel line posts, use 1/4" - 20 self-tapping screws in 0.22" diameter holes or 1/4" bolts in 3/8" diameter holes.

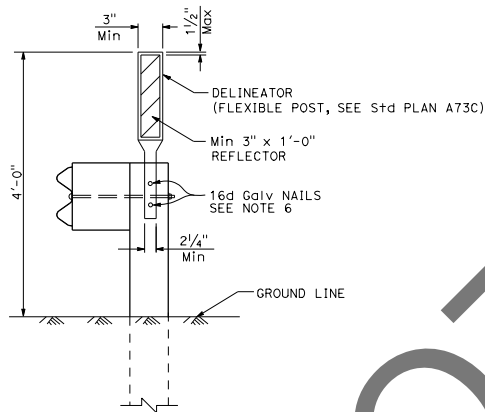

MGS DELINEATION
See Note 3

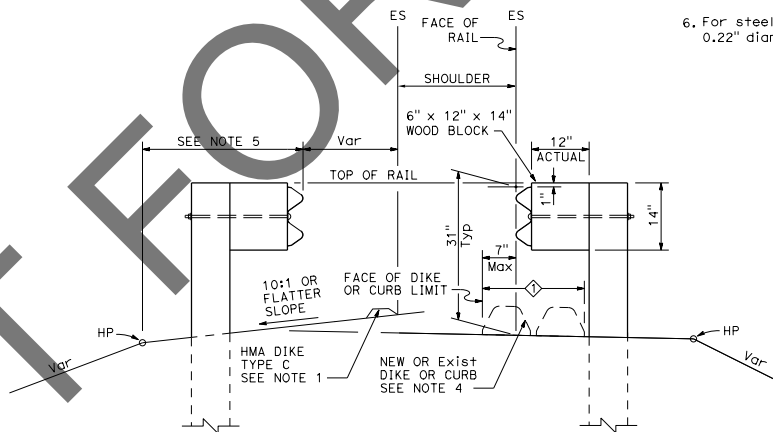

DIKE POSITIONING
See Note 1

◇ PERMISSIBLE DIKE OR CURB PLACEMENT AREA

STATE OF CALIFORNIA
DEPARTMENT OF TRANSPORTATION
**MIDWEST GUARDRAIL SYSTEM
TYPICAL RAILING DELINEATION
AND DIKE POSITIONING DETAILS**
NO SCALE

A77N4

2018 STANDARD PLAN A77N4

Dist	COUNTY	ROUTE	POST MILES TOTAL PROJECT	SHEET No.	TOTAL SHEETS
<i>Randell D. Hiatt</i> REGISTERED CIVIL ENGINEER					
April 19, 2019 PLANS APPROVAL DATE					
THE STATE OF CALIFORNIA OR ITS OFFICERS OR AGENTS SHALL NOT BE RESPONSIBLE FOR THE ACCURACY OR COMPLETENESS OF SCANNED COPIES OF THIS PLAN SHEET.					

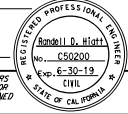

TO ACCOMPANY PLANS DATED _____

NOTES:

- When necessary to place dike more than 7" in front of face of MGS, only Type C dike may be used. For dike details, see Standard Plan A87B.
- For standard railing post embedment, see Standard Plan A77N3.
- MGS delineation to be used where shown on the Project Plans.
- When dike or curb is placed under MGS, the maximum height of the dike or curb shall be 6". Mountable dike should not be used. For dike and curb details, see Standard Plans A87A and A87B.
- For details of typical distance between the face of rail and hinge point, see Standard Plan A77N3.
- For steel line posts, use 1/4" - 20 self-tapping screws in 0.22" diameter holes or 1/4" bolts in 1/2" diameter holes.
- 8" block can be used with 4" or lower dike, or no dike. 12" block can be used with 6" or lower dike, or no dike.

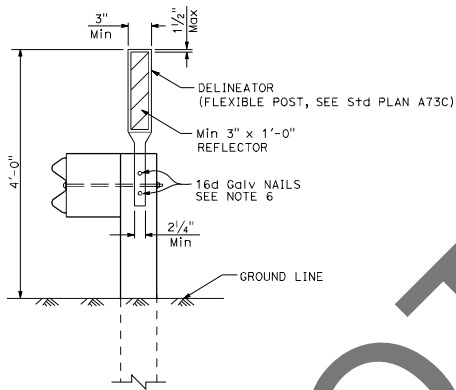

MGS DELINEATION
See Note 3

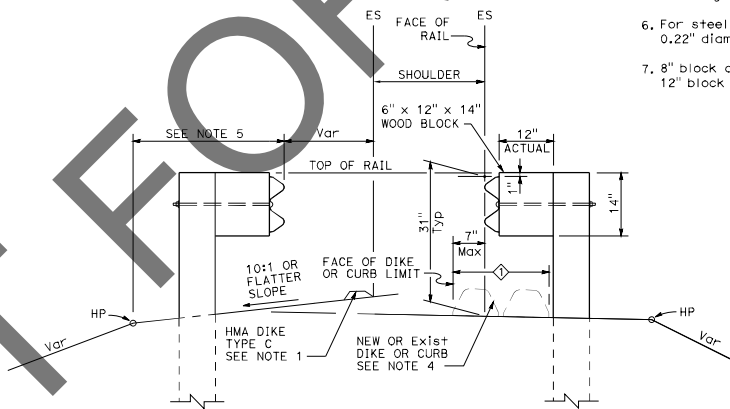

DIKE POSITIONING
See Note 1

◇ PERMISSIBLE DIKE OR CURB
PLACEMENT AREA

STATE OF CALIFORNIA
DEPARTMENT OF TRANSPORTATION
**MIDWEST GUARDRAIL SYSTEM
TYPICAL RAILING DELINEATION
AND DIKE POSITIONING DETAILS**
NO SCALE

RSP A77N4 DATED APRIL 19, 2019 SUPERSEDES STANDARD PLAN A77N4
DATED MAY 31, 2018 - PAGE 64 OF THE STANDARD PLANS BOOK DATED 2018.

REVISED STANDARD PLAN RSP A77N4

2018 REVISED STANDARD PLAN RSP A77N4

NOT FOR BID

Dist	COUNTY	ROUTE	POST MILES TOTAL PROJECT	SHEET No.	TOTAL SHEETS
<i>Chi H. Wong</i> REGISTERED CIVIL ENGINEER No. C54738 Exp. 12-31-19 CIVIL STATE OF CALIFORNIA					
May 31, 2018 PLANS APPROVAL DATE <small>THE STATE OF CALIFORNIA OR ITS OFFICERS OR AGENTS SHALL NOT BE RESPONSIBLE FOR THE ACCURACY OR COMPLETENESS OF SCANNED COPIES OF THIS PLAN SHEET.</small>					

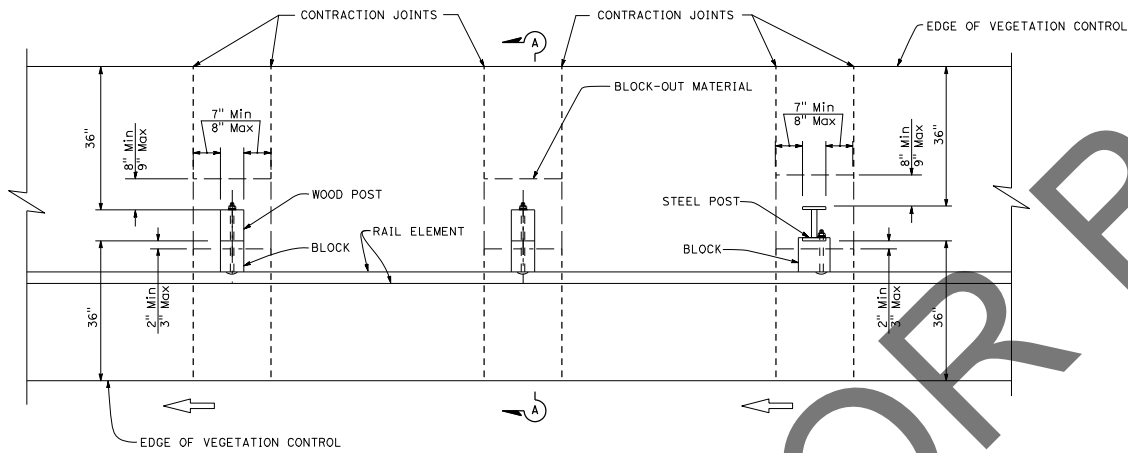

- NOTES:**
1. Where the distance between back of post and hinge point is less than 42", construct vegetation control to 6" from hinge point while maintaining the 8" block-out at back of post.
 2. Where paved shoulder is constructed within 36" in front of the post, construct vegetation control to the edge of paved shoulder.
 3. For wood post sizes, see Standard Plan A77N1.
 4. For steel post sizes, see Standard Plan A77N2.
 5. For details not shown, see Standard Plans A77L1 and A77L2.
 6. Where vegetation control is adjacent to a dike on a cut slope, construct vegetation control flush with the top edge of dike.
 7. Vegetation control must slope to drain water.
 8. Concrete over block-out material depth, construct 3/8" Min to 5/8" Max.
 9. This plan for vegetation control installation only.

PLAN

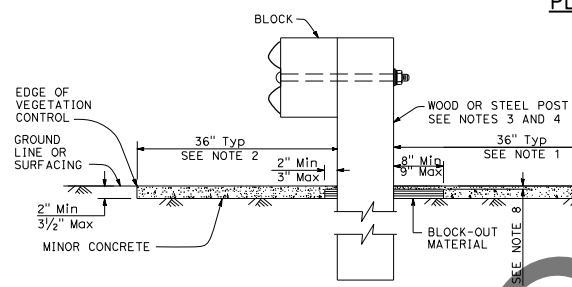

SECTION A-A
Without Existing Dike

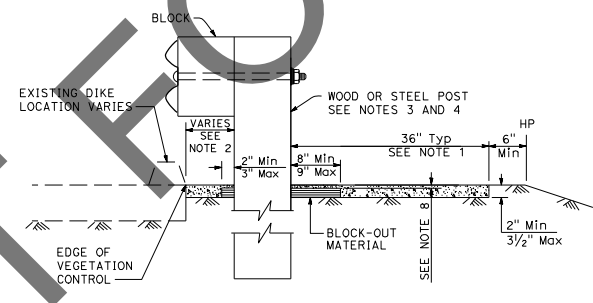

SECTION A-A
With Existing Dike

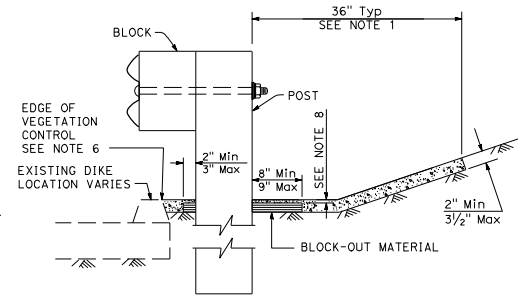

SECTION A-A
With Existing Dike on cut slope

STATE OF CALIFORNIA
DEPARTMENT OF TRANSPORTATION

**MINOR CONCRETE VEGETATION CONTROL
GUARDRAIL SYSTEM**

NO SCALE

A77N5

2018 STANDARD PLAN A77N5

65

NOT FOR CONSTRUCTION

Return to Table of Contents

DIST	COUNTY	ROUTE	POST MILES TOTAL PROJECT	SHEET NO.	TOTAL SHEETS
<i>Chi H. Wong</i> REGISTERED CIVIL ENGINEER					
May 31, 2018 PLANS APPROVAL DATE					
<small>THE STATE OF CALIFORNIA OR ITS OFFICERS OR AGENTS SHALL NOT BE RESPONSIBLE FOR THE ACCURACY OR COMPLETENESS OF SCANNED COPIES OF THIS PLAN SHEET.</small>					

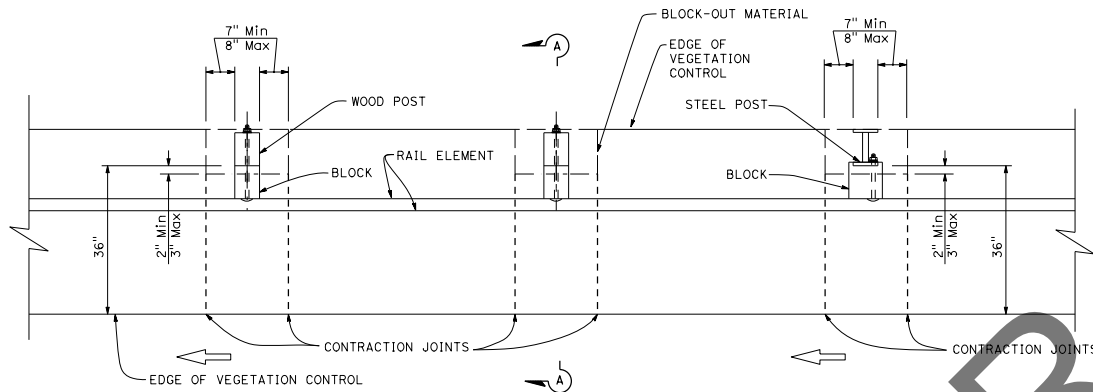

PLAN

NOTES:

1. Use the details on this sheet when the length from the back of post to the hinge point is less than 18". Use the details on Standard Plan A77N5 when the length from the back of the post to the hinge point is greater than 18".
2. Construct vegetation control flush with the back edge of post.
3. Where paved shoulder is constructed within 36" in front of the post, construct vegetation control to the edge of paved shoulder.
4. For wood post sizes, see Standard Plan A77N1.
5. For steel post sizes, see Standard Plan A77N2.
6. For details not shown, see Standard Plans A77L1 and A77L2.
7. Vegetation control must slope to drain water.
8. Concrete over block-out material depth, construct $\frac{3}{8}$ " Min to $\frac{5}{8}$ " Max.
9. This plan for vegetation control installation only.

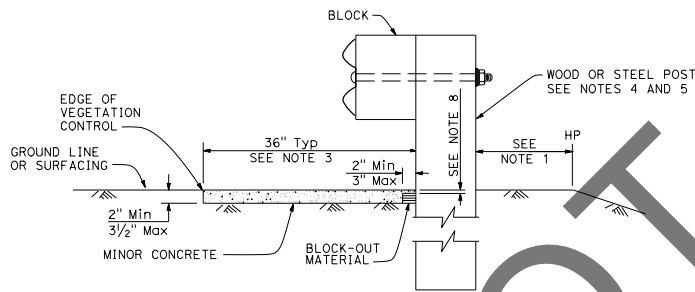

SECTION A-A

Without Existing Dike

STATE OF CALIFORNIA
DEPARTMENT OF TRANSPORTATION

**MINOR CONCRETE VEGETATION CONTROL
GUARDRAIL SYSTEM
NARROW VEGETATION CONTROL INSTALLATION**

NO SCALE

A77N5A

2018 STANDARD PLAN A77N5A

66

Dist	COUNTY	ROUTE	POST MILES TOTAL PROJECT	SHEET No.	TOTAL SHEETS
<i>Chi H. Wong</i> REGISTERED CIVIL ENGINEER					
May 31, 2018 PLANS APPROVAL DATE					
THE STATE OF CALIFORNIA OR ITS OFFICERS OR AGENTS SHALL NOT BE RESPONSIBLE FOR THE ACCURACY OR COMPLETENESS OF SCANNED COPIES OF THIS PLAN SHEET.					

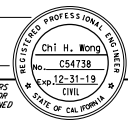

NOTES:

1. See Standard Plan A77N5 for additional vegetation control details.
2. Where the distance between back of post and hinge point is less than 42", construct vegetation control to 6" from hinge point while maintaining the 8" block-out at back of post.
3. Vegetation control must slope to drain water.
4. This plan for vegetation control installation only.

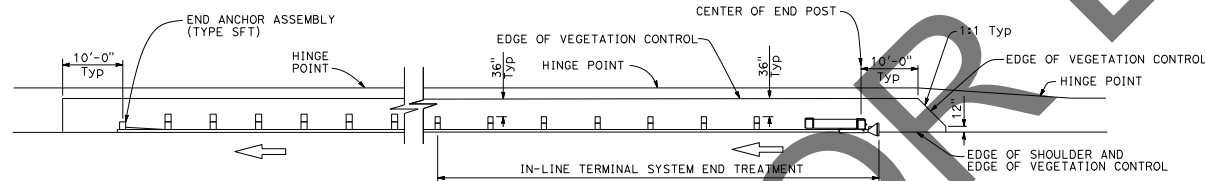

PLAN

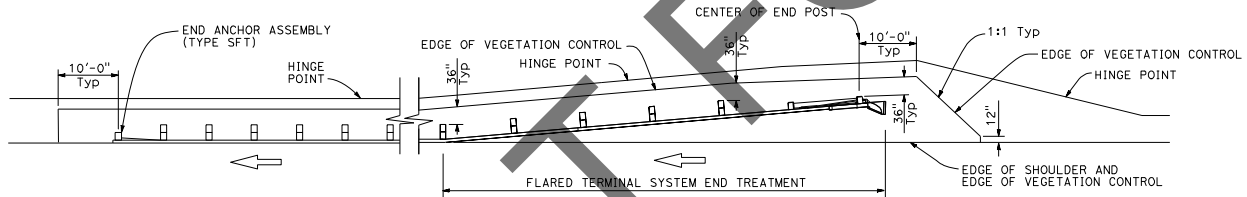

PLAN

NOT FOR BID

2018 STANDARD PLAN A77N6

STATE OF CALIFORNIA
 DEPARTMENT OF TRANSPORTATION
**MINOR CONCRETE VEGETATION CONTROL
 GUARDRAIL SYSTEM
 FOR TERMINAL SYSTEM END TREATMENTS**
 NO SCALE

A77N6

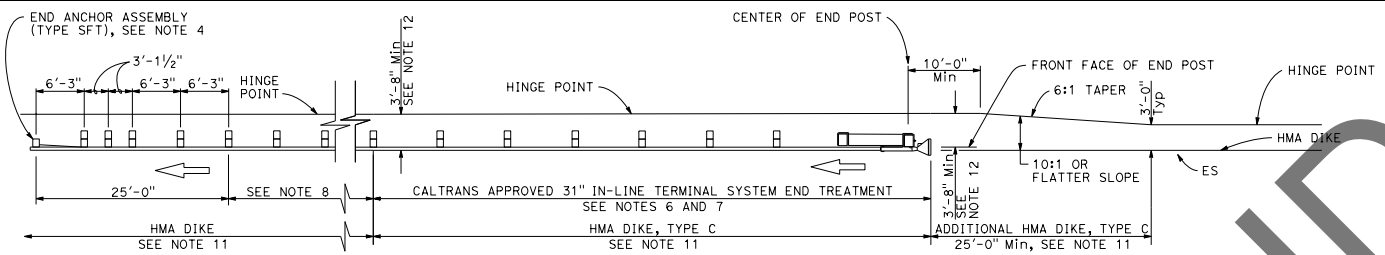

TYPE 11A LAYOUT

(Embankment MGS installation with 31" in-line end treatment at traffic approach end of railing)
See Note 5

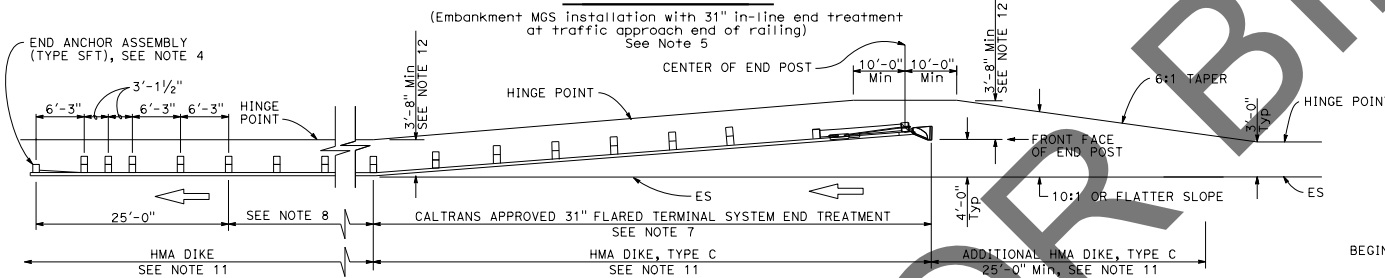

TYPE 11B LAYOUT

(Embankment MGS installation with 31" flared end treatment at traffic approach end of railing)
See Note 5

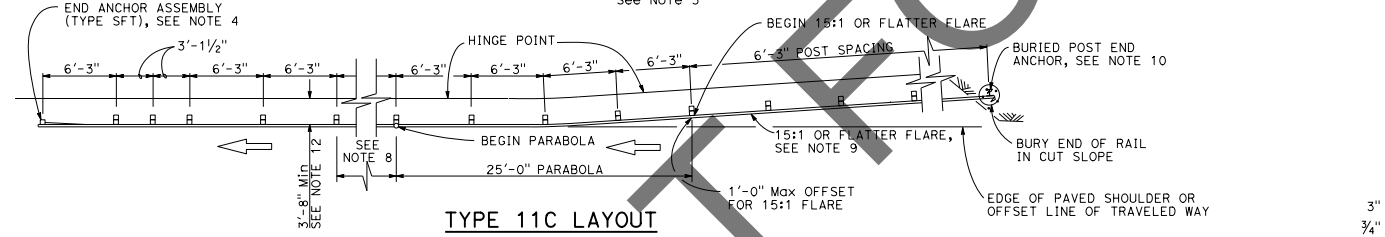

TYPE 11C LAYOUT

(Embankment MGS installation with buried end anchor treatment at traffic approach end of railing)
See Notes 5 and 11

- NOTES:**
- Line post, blocks and hardware to be used are shown on Standard Plans A77L1, A77L2, A77N1, A77N2 and A77M1.
 - MGS post spacing to be 6'-3" center to center, except as otherwise noted.
 - Except as noted, line posts are 6" x 8" x 6'-0" wood with 6" x 8" x 1'-2" wood blocks. W6 x 8.5 or W6 x 9 steel posts, 6'-0" in length, with 6" x 8" x 1'-2" notched wood blocks or recycled plastic blocks may be used for 6" x 8" x 6'-0" wood post with 6" x 8" x 1'-2" wood blocks where applicable and when specified.
 - For End Anchor Assembly (Type SFT) details, see Standard Plan A77S1.
 - Layout Types 11A, 11B or 11C are typically used where MGS is recommended to shield embankment slopes and a crashworthy end treatment is required for only one direction of traffic.
 - 31" in-line terminal system end treatments are used where site conditions will not accommodate a flared end treatment.
 - The type of 31" terminal system end treatment to be used will be shown on the Project Plans.
 - Dependent on site conditions (embankment height and side slope), construction of additional MGS (length equal to multiples of 12'-6" with 6'-3" post spacing) may be advisable.
 - The 15:1 or flatter flare used with buried end anchors is based on the edge of the paved shoulder or offset line of edge of the traveled way. The length of MGS within the 15:1 or flatter flare is based on site conditions and should be a length equal to multiples of 12'-6".
 - For details of the buried post end anchor used with Type 11C Layout, see Standard Plan A77T2.
 - Where placement of dike is required with MGS installations, see Standard Plan A77N4 for dike positioning details.
 - Use this offset for 8-inch block. For 12-inch block, use 4'-0" Min offset.

DIST	COUNTY	ROUTE	POST MILES TOTAL PROJECT	SHEET NO.	TOTAL SHEETS
------	--------	-------	--------------------------	-----------	--------------

Randell D. Hiatt
REGISTERED CIVIL ENGINEER

May 31, 2018
PLANS APPROVAL DATE

THE STATE OF CALIFORNIA OR ITS OFFICERS OR AGENTS SHALL NOT BE RESPONSIBLE FOR THE ACCURACY OR COMPLETENESS OF SCANNED COPIES OF THIS PLAN SHEET.

REGISTERED PROFESSIONAL ENGINEER
No. C50200
Exp. 6-30-19
CIVIL
STATE OF CALIFORNIA

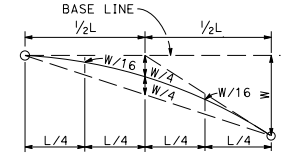

TYPICAL PARABOLIC LAYOUT

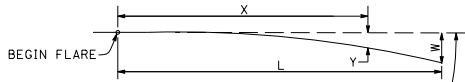

BASE LINE (EDGE OF PAVED SHOULDER OR OFFSET LINE OF EDGE OF TRAVELED WAY)

Y = OFFSET FROM BASE LINE
W = MAXIMUM OFFSET
X = DISTANCE ALONG BASE LINE
L = LENGTH OF FLARE

$$Y = \frac{WX^2}{L^2}$$

PARABOLIC FLARE OFFSETS

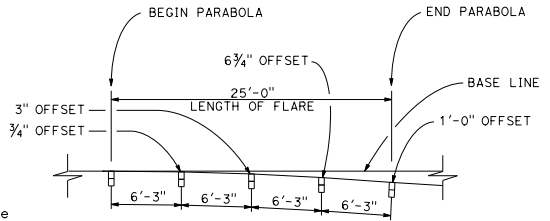

TYPICAL FLARE OFFSETS FOR 1 FOOT Max END OFFSET

STATE OF CALIFORNIA
DEPARTMENT OF TRANSPORTATION

**MIDWEST GUARDRAIL SYSTEM
TYPICAL LAYOUTS FOR
EMBANKMENTS**

NO SCALE

A77P1

DIST	COUNTY	ROUTE	POST MILES TOTAL PROJECT	SHEET NO.	TOTAL SHEETS

Mark Ballentine
REGISTERED CIVIL ENGINEER
No. CE4101
Exp. 09-30-22
STATE OF CALIFORNIA

April 15, 2022
PLANS APPROVAL DATE

THE STATE OF CALIFORNIA OR ITS OFFICERS OR AGENTS SHALL NOT BE RESPONSIBLE FOR THE ACCURACY OR COMPLETENESS OF SCANNED COPIES OF THIS PLAN SHEET.

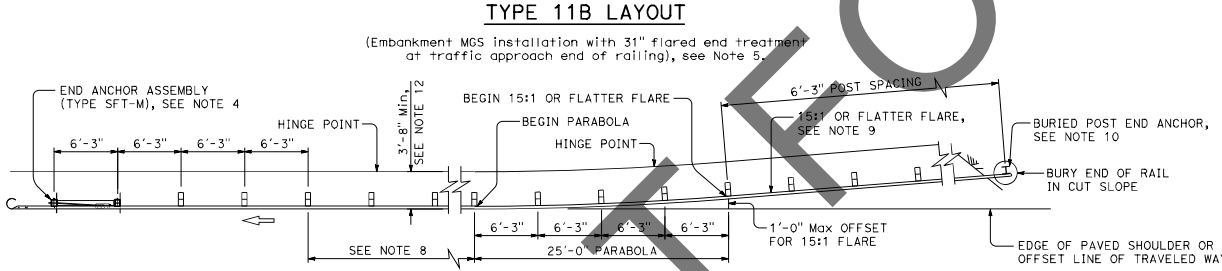
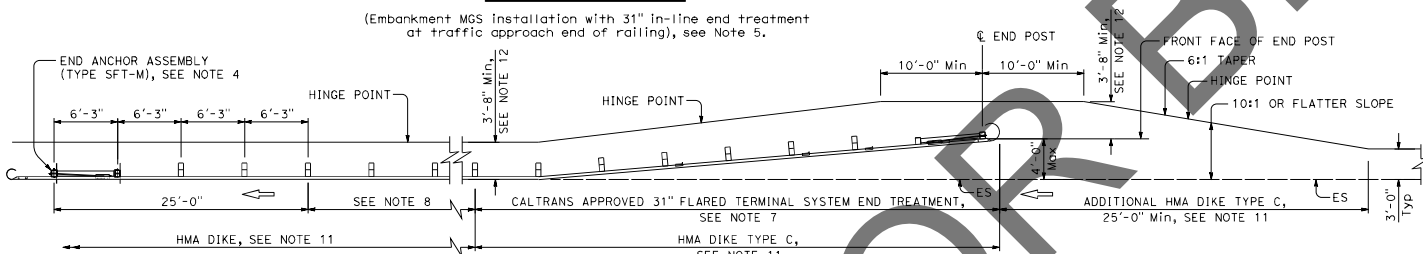
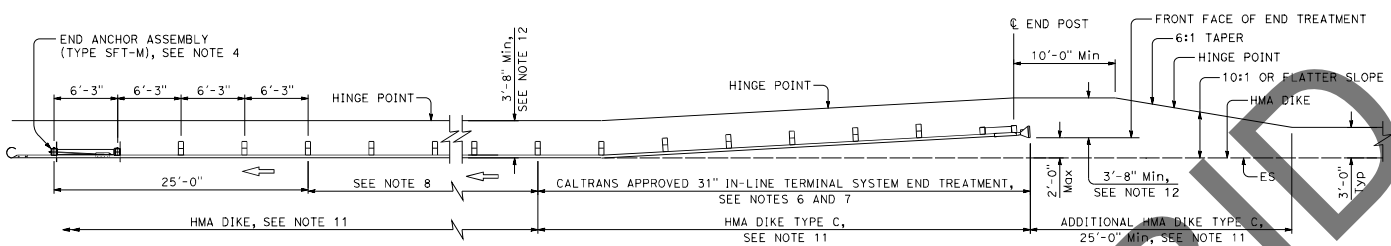

- NOTES:**
- Line post, blocks and hardware to be used are shown on Revised Standard Plans RSP A77L1, RSP A77L2, RSP A77N1, RSP A77N2 and RSP A77M1.
 - MGS post spacing to be 6'-3" center to center, except as otherwise noted.
 - Except as noted, line posts are 6" x 8" x 6'-0" wood with 6" x 8" x 1'-2" wood blocks, W6 x 8.5 or W6 x 9 steel posts, 6'-0" in length, with 6" x 8" x 1'-2" notched wood blocks or recycled plastic blocks may be used for 6" x 8" x 6'-0" wood post with 6" x 8" x 1'-2" wood blocks where applicable and when specified.
 - For End Anchor Assembly (Type SFT-M) details, see Revised Standard Plan RSP A77S1.
 - Layout Types 11A, 11B or 11C are typically used where MGS is recommended to shield embankment slopes and a crashworthy end treatment is required for only one direction of traffic.
 - 31" in-line terminal system end treatments are used where site conditions will not accommodate a flared end treatment.
 - The type of 31" terminal system end treatment to be used will be shown on the Project Plans.
 - Dependent on site conditions (embankment height and side slope), construction of additional MGS (length equal to multiples of 12'-6" with 6'-3" post spacing) may be advisable.
 - The 15:1 or flatter flare used with buried end anchors is based on the edge of the paved shoulder or offset line of edge of the traveled way.
 - For details of the buried post end anchor used with Type 11C Layout, see Revised Standard Plans RSP A77T2 and RSP A77T3.
 - Where placement of dike is required with MGS installations, see Revised Standard Plan RSP A77N4 for dike positioning details.
 - Use this offset for 8-inch block. For 12-inch block, use 4'-0" Min offset.

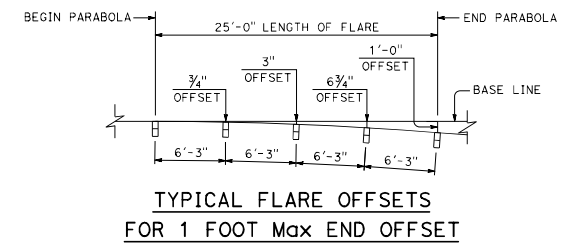
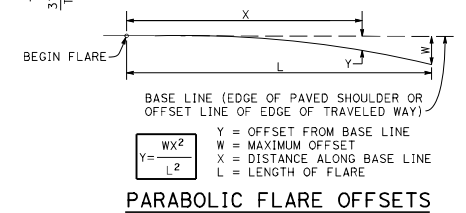
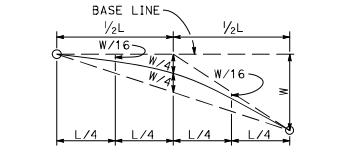

STATE OF CALIFORNIA
DEPARTMENT OF TRANSPORTATION
**MIDWEST GUARDRAIL SYSTEM
TYPICAL LAYOUTS FOR
EMBANKMENTS**
NO SCALE

RSP A77P1 DATED APRIL 15, 2022 SUPERSEDES RSP A77P1 DATED OCTOBER 18, 2019 AND STANDARD PLAN A77P1 DATED MAY 31, 2018 - PAGE 80 OF THE STANDARD PLANS BOOK DATED 2018.

REVISED STANDARD PLAN RSP A77P1

2018 REVISED STANDARD PLAN RSP A77P1

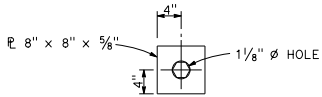

DETAIL "A"
CABLE CONNECTION
END PLATE

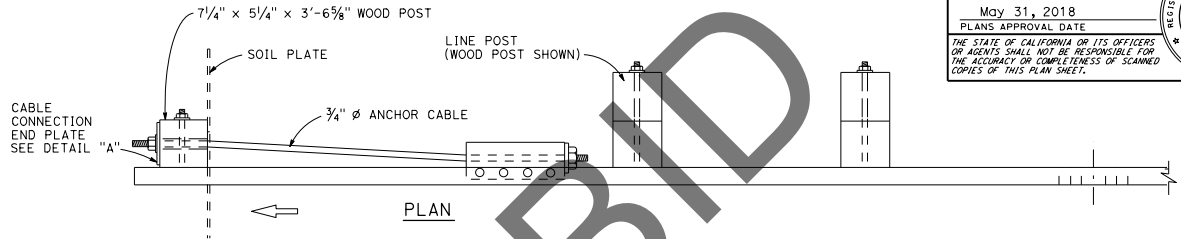

PLAN

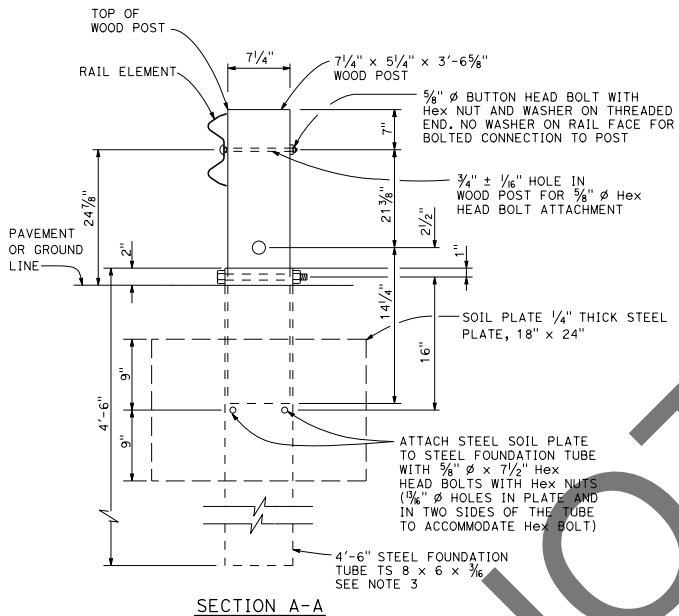

SECTION A-A

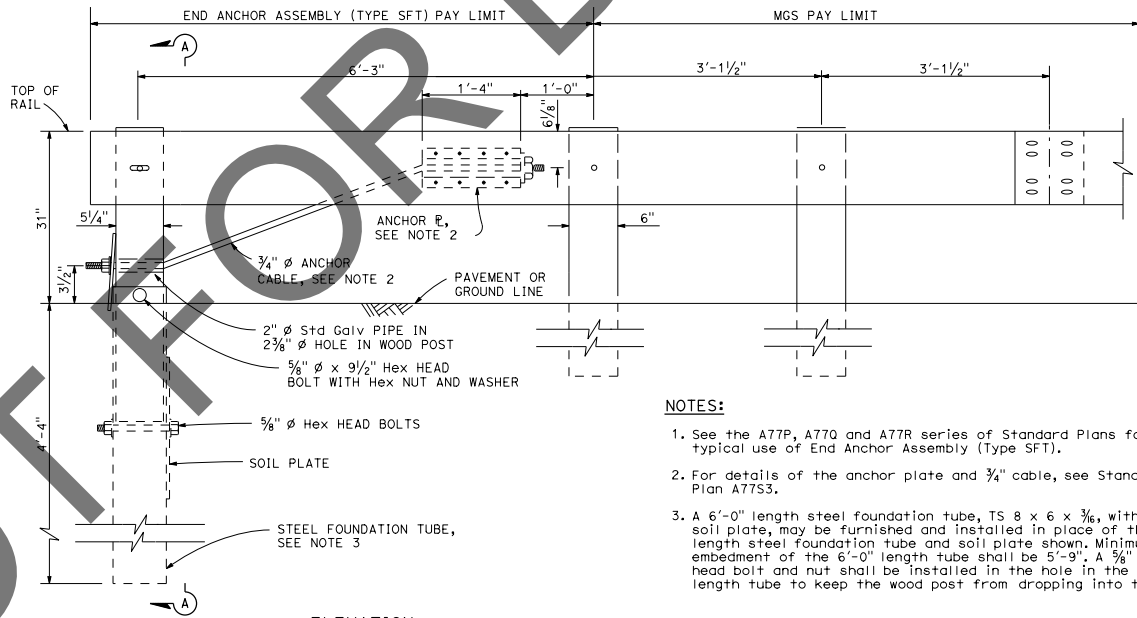

ELEVATION

END ANCHOR
ASSEMBLY (TYPE SFT)

See Note 1

NOTES:

1. See the A77P, A77Q and A77R series of Standard Plans for typical use of End Anchor Assembly (Type SFT).
2. For details of the anchor plate and 3/4" cable, see Standard Plan A77S3.
3. A 6'-0" length steel foundation tube, TS 8 x 6 x 3/8, without a soil plate, may be furnished and installed in place of the 4'-6" length steel foundation tube and soil plate shown. Minimum embedment of the 6'-0" length tube shall be 5'-9". A 3/8" diameter hex head bolt and nut shall be installed in the hole in the 6'-0" length tube to keep the wood post from dropping into the tube.

STATE OF CALIFORNIA
DEPARTMENT OF TRANSPORTATION

MIDWEST GUARDRAIL SYSTEM
END ANCHOR ASSEMBLY
(TYPE SFT)

NO SCALE

A77S1

Dist	COUNTY	ROUTE	POST MILES TOTAL PROJECT	SHEET No.	TOTAL SHEETS

Randell D. Hiatt
REGISTERED CIVIL ENGINEER

May 31, 2018
PLANS APPROVAL DATE

THE STATE OF CALIFORNIA OR ITS OFFICERS OR AGENTS SHALL NOT BE RESPONSIBLE FOR THE ACCURACY OR COMPLETENESS OF SCANNED COPIES OF THIS PLAN SHEET.

REGISTERED PROFESSIONAL ENGINEER
Randell D. Hiatt
No. C60200
Exp. 6-30-19
CIVIL
STATE OF CALIFORNIA

DIST	COUNTY	ROUTE	POST MILES TOTAL PROJECT	SHEET NO.	TOTAL SHEETS

Mark Ballentine
 REGISTERED CIVIL ENGINEER
 No. CE4101
 Exp. 09-30-22
 CIVIL
 STATE OF CALIFORNIA

April 15, 2022
 PLANS APPROVAL DATE
 THE STATE OF CALIFORNIA OR ITS OFFICERS OR AGENTS SHALL NOT BE RESPONSIBLE FOR THE ACCURACY OR COMPLETENESS OF SCANNED COPIES OF THIS PLAN SHEET.

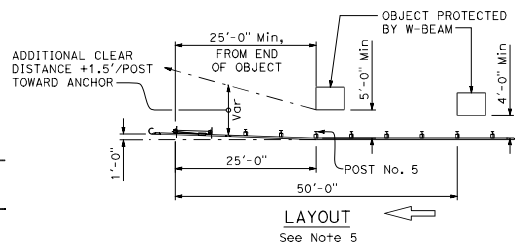
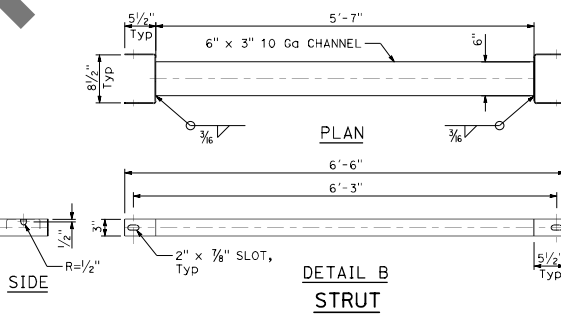
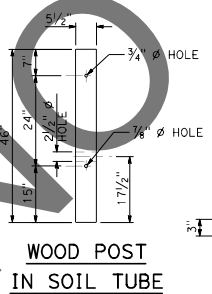
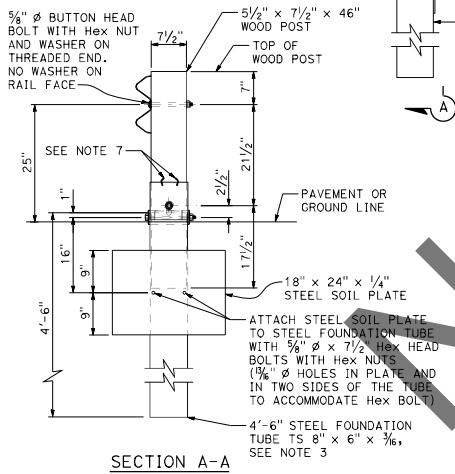
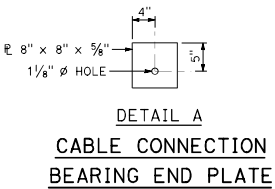
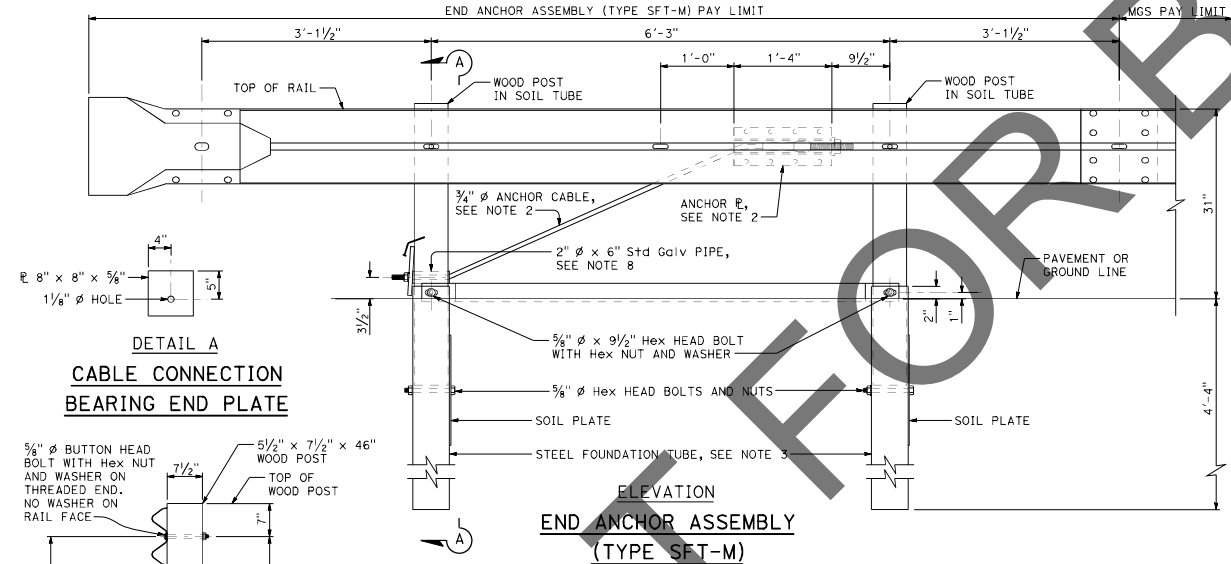
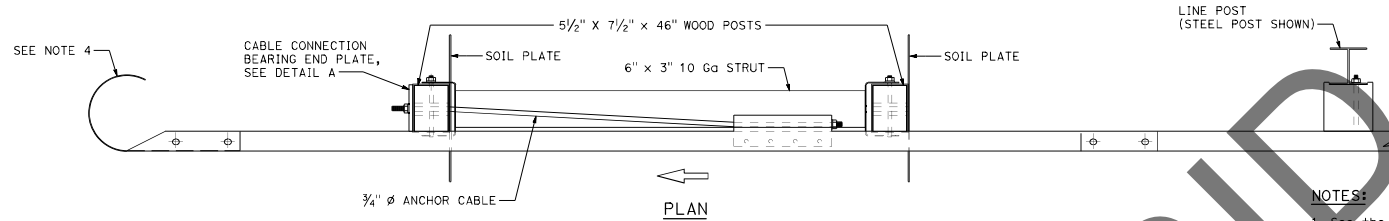

- NOTES:
- See the A77P, A770 and A77R series of Standard Plans for typical use of End Anchor Assembly (Type SFT-M).
 - For details of the anchor plate and 3/4" cable, see Revised Standard Plan RSP A7753.
 - A 6'-0" length steel foundation tube, TS 8" x 6" x 3/8", without a soil plate, may be furnished and installed in place of the 4'-6" length steel foundation tube and soil plate shown. Minimum embedment of the 6'-0" length tube shall be 5'-9". A 5/8" Ø Hex head bolt and nut shall be installed in the hole in the 6'-0" length tube to keep the wood post from dropping into the tube.
 - Place End Cap Type B when pedestrians, bicycles or traffic is within contact of the trailing end of the exposed element or rail element may be cut 1" past the end of the post. Clean, treat and cut off sharp edges.
 - Increased clear distance behind the rail is required from 50' prior to the last post of the End Anchor Assembly (Type SFT-M). Beginning at 50' upstream of the last post of the End Anchor Assembly, the required clear distance increases to 5' at post No. 5. From post No. 5 to the last post of the End Anchor Assembly, the required clear distance increases at a rate of 1.5' for each post.
 - Dike with a maximum height of 4" may be placed under or in front of the End Anchor Assembly (Type SFT-M). If the anchor posts are in conflict with the 4" high dike, the last 25' of rail may be tapered back a maximum of 1'-0" to allow the dike to maintain alignment.
 - Secure End Plate with two 16d nails to maintain alignment.
 - 2" Ø Standard Galvanized Pipe or 2 3/8" Ø Galvanized Pipe.

STATE OF CALIFORNIA
 DEPARTMENT OF TRANSPORTATION
**MIDWEST GUARDRAIL SYSTEM
 END ANCHOR ASSEMBLY
 (TYPE SFT-M)**
 NO SCALE
 RSP A7751 DATED APRIL 15, 2022 SUPERSEDES STANDARD PLAN A7751
 DATED MAY 31, 2018 - PAGE 99 OF THE STANDARD PLANS BOOK DATED 2018.

REVISED STANDARD PLAN RSP A7751

2018 REVISED STANDARD PLAN RSP A7751

DIST	COUNTY	ROUTE	POST MILES TOTAL PROJECT	SHEET NO.	TOTAL SHEETS

Randell D. Hiett
REGISTERED CIVIL ENGINEER

April 19, 2019
PLANS APPROVAL DATE

THE STATE OF CALIFORNIA OR ITS OFFICERS OR AGENTS SHALL NOT BE RESPONSIBLE FOR THE ACCURACY OR COMPLETENESS OF SCANNED COPIES OF THIS PLAN SHEET.

REGISTERED PROFESSIONAL ENGINEER
No. C50200
Exp. 6-30-19
STATE OF CALIFORNIA

- NOTES:**
- TO ACCOMPANY PLANS DATED _____
- Use 5/8" Ø Button head bolts and hex nuts for connections to posts. No washer on rail face for bolted connections to post.
 - The nested rail elements, end cap, and "W" beam to thrie beam element may be spliced together prior to bolting the elements to the wood post and concrete barrier or railing.
 - Exterior splice bolt holes for rail element splices at Post No. T5 and the connection to the concrete barrier or railing shall be the standard 7/8" x 1/8" slot size. Interior splice bolt holes at these locations may be increased up to 1 1/4" Ø. Only the top 4 and the bottom 4 splice bolts with washers and nuts are required for rail splices at Post No. T5 and the connection to the concrete barrier or railing.
 - The top elevation of Posts No. T2 through No. T7 shall not project more than 1" above the top elevation of the rail element.
 - Typically, the railing connected to Transition Railing (Type WB-31) will be either standard railing section of MGS or a Caltrans approved 31" end treatment attached to Post No. T1.
 - The depth of the metal box spacer varies from the 9/8" to 1 1/2" and is dependent on the width of the concrete railing or wall. The combined dimension for the depth of the metal box spacer plus the width of railing or wall is typically 21 1/8". Where the space between the backside of the concrete railing or wall and the rear thrie beam element is less than 1 1/2", metal plates similar to Plate 'A' are to be used as spacers.
 - Where the width of the concrete railing or wall is greater than 17 1/8", wood blocks are to be used to fill the space created between the backside of Posts No. T5 through No. T8 and the rear thrie beam element. These wood blocks shall be 8" in width and 1'-2" in length. The dimension between the front thrie beam element and the rear thrie beam element is to match the width of the concrete railing or wall.
 - End cap may be installed over 12 gauge and 10 gauge thrie beam elements where transition railing is installed on the departure end of bridge railing.
 - Conform standard railing section height to 31" at Post No. T1 using height transition ratio of 150:1. MGS tolerance at post No. T1 is ± 1".

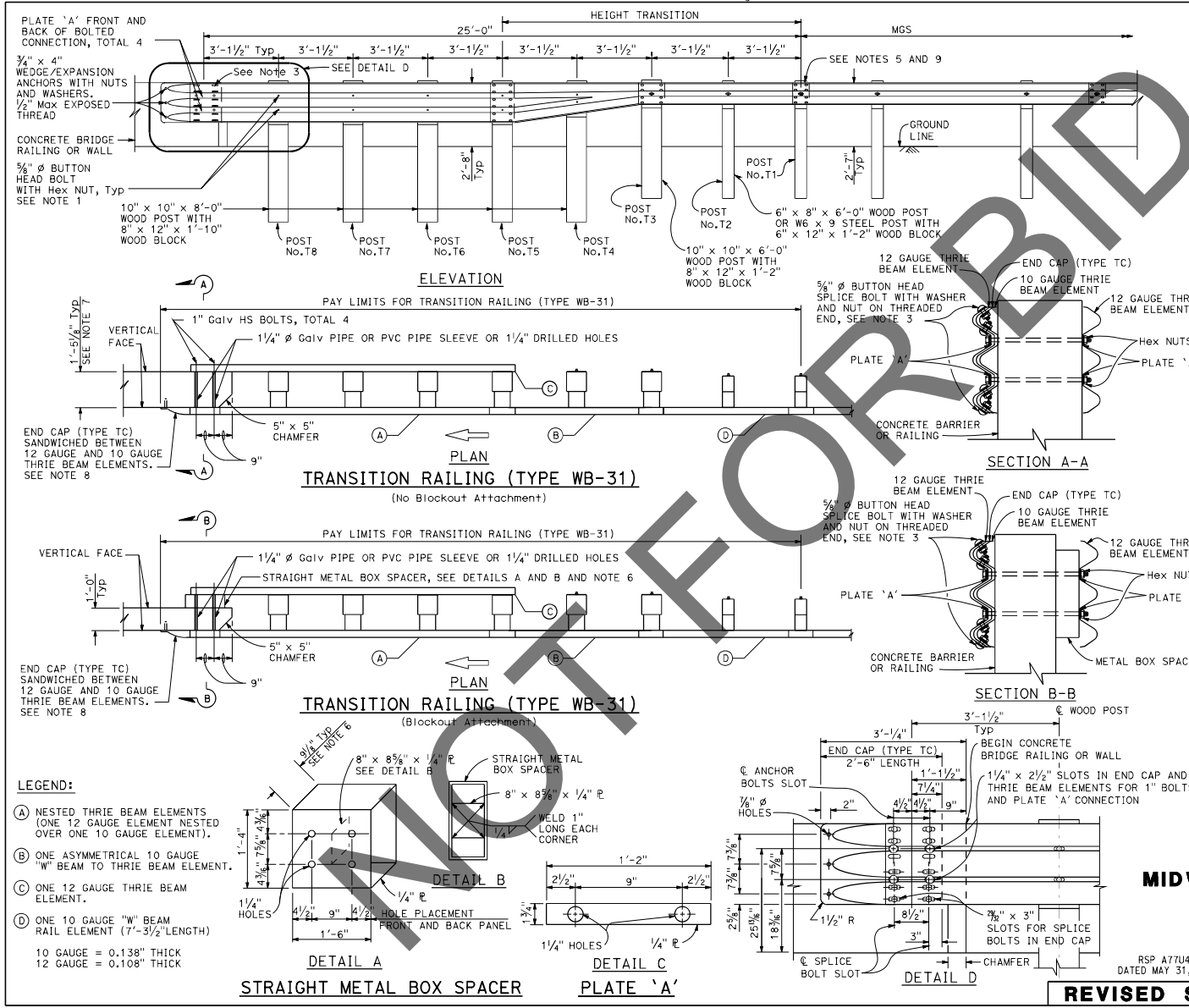

REVISED STANDARD PLAN RSP A77U4

STATE OF CALIFORNIA
DEPARTMENT OF TRANSPORTATION

**MIDWEST GUARDRAIL SYSTEM
TRANSITION RAILING
(TYPE WB-31)**

NO SCALE

RSP A77U4 DATED APRIL 19, 2019 SUPERSEDES STANDARD PLAN A77U4
DATED MAY 31, 2018 - PAGE 107 OF THE STANDARD PLANS BOOK DATED 2018.

2018 REVISED STANDARD PLAN RSP A77U4

Dist	COUNTY	ROUTE	POST MILES TOTAL PROJECT	SHEET No.	TOTAL SHEETS
 REGISTERED CIVIL ENGINEER					
May 31, 2018 PLANS APPROVAL DATE					
THE STATE OF CALIFORNIA OR ITS OFFICERS OR AGENTS SHALL NOT BE RESPONSIBLE FOR THE ACCURACY OR COMPLETENESS OF SCANNED COPIES OF THIS PLAN SHEET.					

REGISTERED PROFESSIONAL ENGINEER
 Hector David Eorogova
 No. C41987
 Exp. 3-31-20
 CIVIL
 STATE OF CALIFORNIA

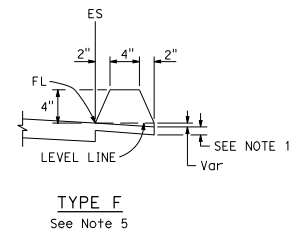
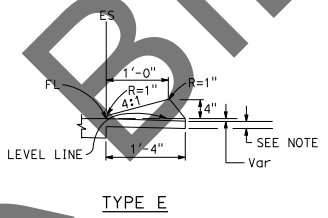
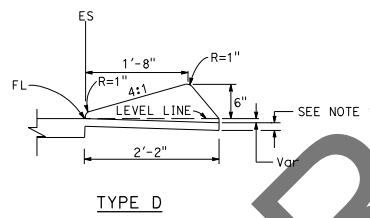
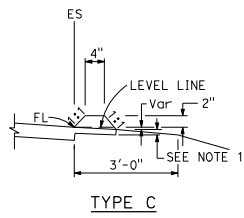
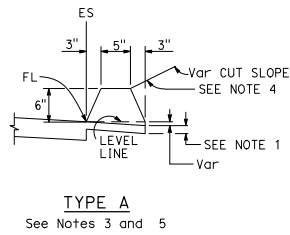

DIKES

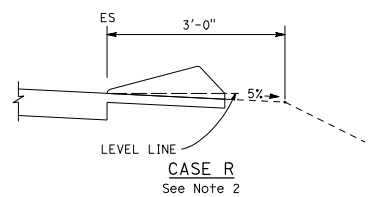
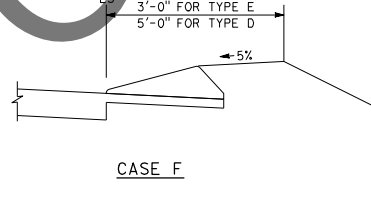
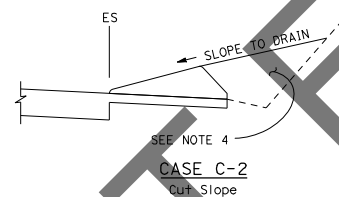
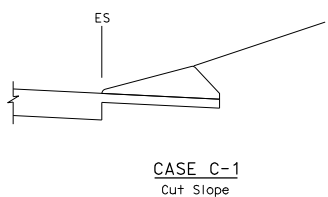

TYPE D AND E BACKFILL DETAILS

NOTES:

- For HMA shoulders only, extend top layer of HMA placed on the shoulder under dike with no joint at the ES. For projects with OGFC shoulders, do not extend OGFC under dike. See project plans for modified dike detail.
- Case R applies to retrofit only projects where restrictive conditions do not provide enough width for Case F backfill.
- Type A dike only to be used where restrictive slope conditions do not provide enough width to use Type D or Type E dike.
- Fill and compact with excavated material to top of dike.
- Use Type A or F dike, where dike is required with guardrail installations. See Standard Plan A77N4 for dike positioning details. See Standard Plan A77N3 for hinge point offsets with guardrail.

DIKE QUANTITIES

TYPE	CUBIC YARDS PER LINEAR FOOT
A	0.0135
C	0.0038
D	0.0293
E	0.0130
F	0.0066

Quantities based on 5% cross slope.

STATE OF CALIFORNIA
DEPARTMENT OF TRANSPORTATION
HOT MIX ASPHALT DIKES

NO SCALE

A87B

DIST	COUNTY	ROUTE	POST MILES TOTAL PROJECT	SHEET No.	TOTAL SHEETS

Randell D. Hiatt REGISTERED CIVIL ENGINEER	
May 31, 2018 PLANS APPROVAL DATE	No. C50200 Exp. 6-30-19 CIVIL STATE OF CALIFORNIA

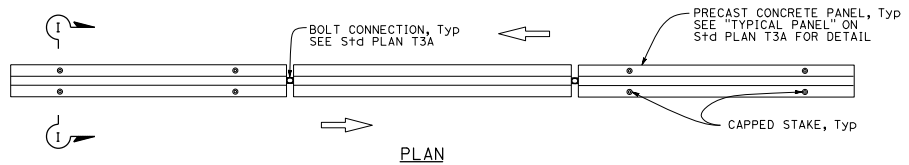

RAILING STAKING CONFIGURATION FOR TWO-WAY TRAFFIC
See Note 2

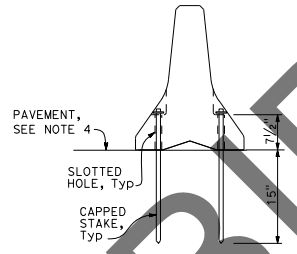

NOTES:

1. Where Type K Temporary Railing is placed on curves and radii that are too severe to connect panels with bolted joints, the railing must be backed continuously with earth fill. See Section F-F.
2. Where Type K Temporary Railing is placed as a temporary or long term barrier in two-way traffic on highways with less than 24" from the edge of traveled way, use four capped stakes per every other panel with end panels staked.
3. Where Type K Temporary Railing is placed 3" to 24" from the edge of an excavation on highways, use two capped stakes per panel along the traffic side.
4. Staked Type K Temporary Railing must be supported by at least 4" thick concrete, hot mix asphalt or existing asphalt concrete pavement.
5. The minimum yield strength for the washer must be 60,000 psi.

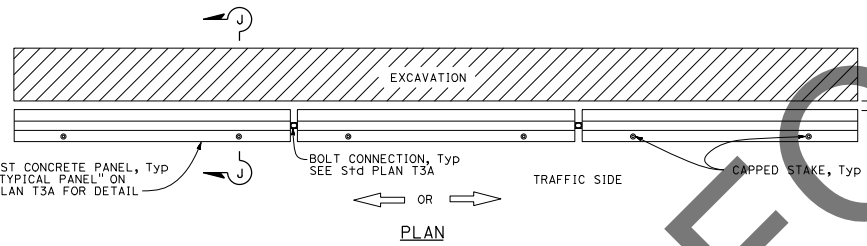

RAILING STAKING CONFIGURATION ADJACENT TO AN EXCAVATION
See Note 3

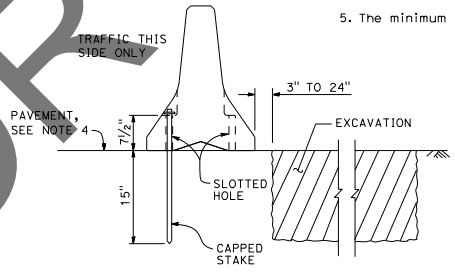

SECTION J-J

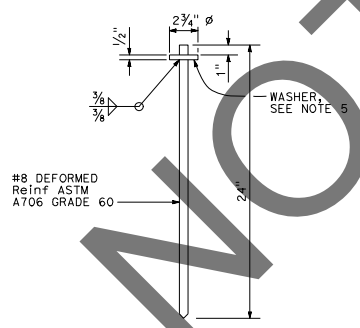

CAPPED STAKE DETAIL

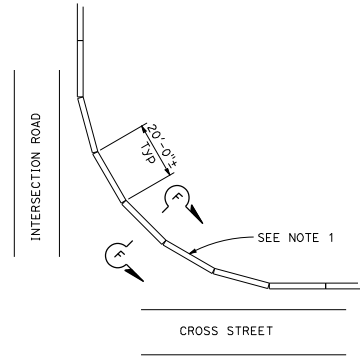

CURVED LAYOUT

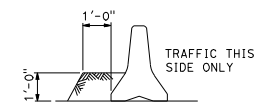

SECTION F-F
See Note 1

STATE OF CALIFORNIA
DEPARTMENT OF TRANSPORTATION
TEMPORARY RAILING (TYPE K)

NO SCALE

T3B

2018 STANDARD PLAN T3B

282



Dist	COUNTY	ROUTE	POST MILES TOTAL PROJECT	SHEET TOTAL No. SHEETS
 REGISTERED CIVIL ENGINEER				
May 31, 2018 PLANS APPROVAL DATE				
<small>THE STATE OF CALIFORNIA OR ITS OFFICERS OR AGENTS SHALL NOT BE RESPONSIBLE FOR THE ACCURACY OR COMPLETENESS OF SCANNED COPIES OF THIS PLAN SHEET.</small>				

TABLE 1

SPEED (S)	MINIMUM TAPER LENGTH * FOR WIDTH OF OFFSET 12 FEET (W)				MAXIMUM CHANNELIZING DEVICE SPACING		
	TANGENT 2L	MERGING L	SHIFTING L/2	SHOULDER L/3	X	Y	Z **
					TAPER	TANGENT	CONFLICT
mph	ft	ft	ft	ft	ft	ft	ft
20	160	80	40	27	20	40	10
25	250	125	63	42	25	50	12
30	360	180	90	60	30	60	15
35	490	245	123	82	35	70	17
40	640	320	160	107	40	80	20
45	1080	540	270	180	45	90	22
50	1200	600	300	200	50	100	25
55	1320	660	330	220	50	100	25
60	1440	720	360	240	50	100	25
65	1560	780	390	260	50	100	25
70	1680	840	420	280	50	100	25
75	1800	900	450	300	50	100	25

* - For other offsets, use the following merging taper length formula for L:
 For speed of 40 mph or less, $L = WS^2/60$
 For speed of 45 mph or more, $L = WS$

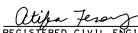
Where: L = Taper length in feet
 W = Width of offset in feet

S = Posted speed limit, off-peak 85th-percentile speed prior to work starting, or the anticipated operating speed in mph

** - Use for taper and tangent sections where there are no pavement markings or where there is a conflict between existing pavement markings and channelizers (CA).

TABLE 2

SPEED *	Min D **	DOWNGRADE Min D ***		
		-3%	-6%	-9%
		ft	ft	ft
20	115	116	120	126
25	158	158	165	173
30	200	205	215	227
35	250	257	271	287
40	305	315	333	354
45	360	378	400	427
50	425	446	474	507
55	495	520	553	593
60	570	598	638	686
65	645	682	728	785
70	730	771	825	891
75	820	866	927	1003

* - Speed is posted speed limit, off-peak 85th-percentile speed prior to work starting, or the anticipated operating speed in mph

** - Longitudinal buffer space or flagger station spacing

*** - Use on sustained downgrade steeper than -3 percent and longer than 1 mile.

TABLE 3

ROAD TYPE	DISTANCE BETWEEN SIGNS *		
	A	B	C
	ft	ft	ft
URBAN - 25 mph OR LESS	100	100	100
URBAN - MORE THAN 25 mph TO 40 mph	250	250	250
URBAN - MORE THAN 40 mph	350	350	350
RURAL	500	500	500
EXPRESSWAY / FREEWAY	1000	1500	2640

* - The distances are approximate, are intended for guidance purposes only, and should be applied with engineering judgment. These distances should be adjusted by the engineer for field conditions, if necessary, by increasing or decreasing the recommended distances.

STATE OF CALIFORNIA
 DEPARTMENT OF TRANSPORTATION

**TRAFFIC CONTROL SYSTEM TABLES
 FOR LANE AND RAMP CLOSURES**

NO SCALE

Dist	COUNTY	ROUTE	POST MILES TOTAL PROJECT	SHEET NO.	TOTAL SHEETS

Atifa Farouq
REGISTERED CIVIL ENGINEER
No. CB0402
Exp. 3-31-19
STATE OF CALIFORNIA

May 31, 2018
PLANS APPROVAL DATE

THE STATE OF CALIFORNIA OR ITS OFFICERS OR AGENTS SHALL NOT BE RESPONSIBLE FOR THE ACCURACY OR COMPLETENESS OF SCANNED COPIES OF THIS PLAN SHEET.

NOTES:
 Use Standard Plan T9 for tables.
 Use cone spacing X for taper segment, Y for tangent segment or Z for conflict situations, as appropriate, per Table 1, unless X, Y, or Z cone spacing is shown on this sheet.
 Provide at least one person to continuously maintain traffic control devices for lane closures.

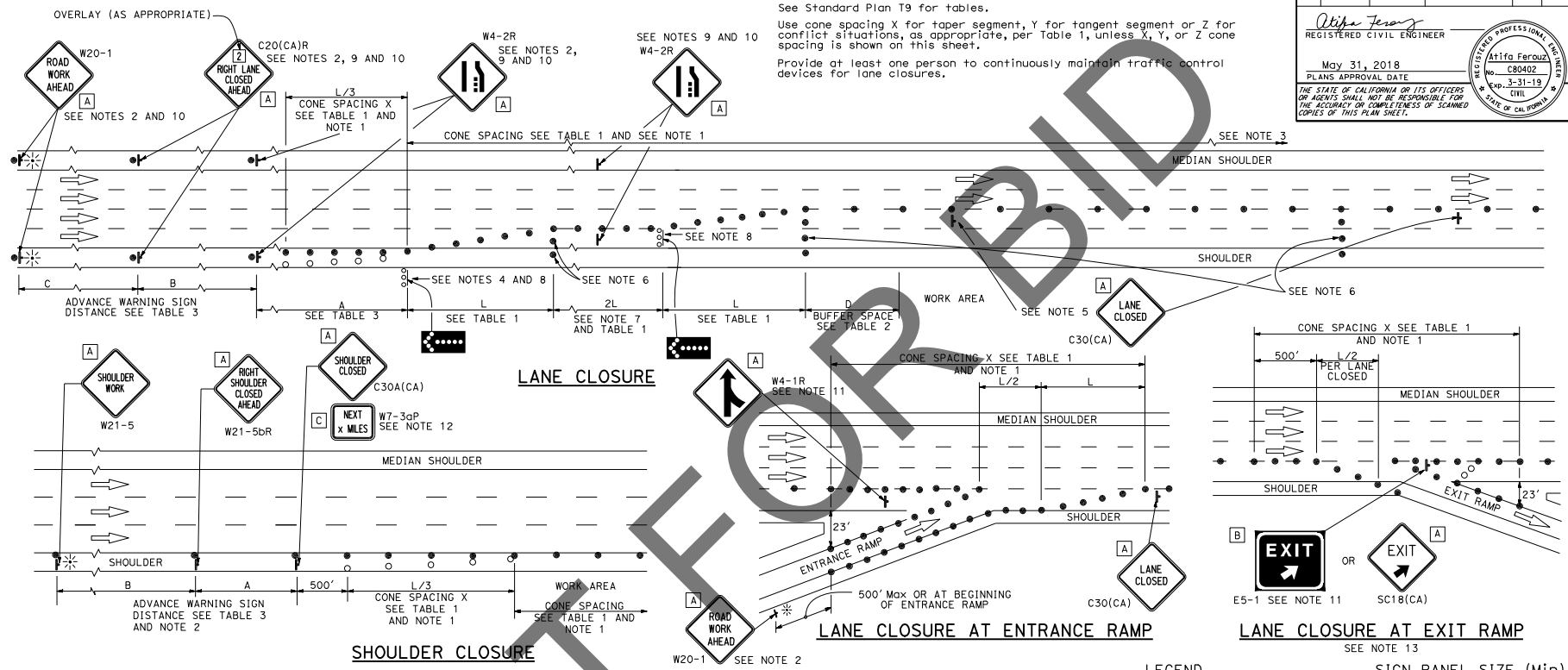

- NOTES:**
1. Portable delineators placed at one-half the spacing indicated for traffic cones may be used instead of cones for daytime closures only.
 2. Each advance warning sign shall be equipped with at least two flags for daytime closure. Each flag shall be at least 16" x 16" in size and shall be orange or fluorescent red-orange in color. Flashing beacons shall be placed at the locations indicated for lane closure during hours of darkness.
 3. A G20-2 "END ROAD WORK" sign, with minimum size of 48" x 24" as appropriate, shall be placed at the end of the lane closure unless the end of work area is obvious or ends within the larger project's limits.
 4. A minimum 1500' sight distance shall be provided where possible for vehicles approaching the first flashing arrow sign. Lane closures shall not begin at the top of crest vertical curve or on a horizontal curve.
 5. Place a C30(CA) sign every 1000' throughout length of lane closure.
 6. A minimum of 3 cones shall be placed transversely across each closed lane and shoulder at each location where a taper across a traffic lane ends and every 1000' as shown on the "Lane Closure" detail. Two type II barricades may be used instead of the 3 cones. The transverse alignment of the cones or barricades on the closed shoulder may be shifted from the transverse alignment to provide access to the work.
 7. The 2L tangent shown along lane lines shall be used between the L tapers required for each closed traffic lane.
 8. Use one flashing arrow sign for each lane closed. The flashing arrow sign shall be Type I.
 9. Median lane closures shall conform to the details as shown except that C20(CA)L and W4-2L signs shall be used.

10. Duplicate sign installations are not required:
 - a) On opposite shoulder if at least one-half of the available lanes remain open to traffic.
 - b) In the median if the width of the median shoulder is less than 8' and the outside lanes are to be closed.
11. The E5-1 or SC18(CA) and W4-1 signs shall be used as shown.
12. A W7-3aP "NEXT _____ MILES" plaque must be used if the shoulder closure extends beyond the distance that can be perceived by road users.
13. For the warning sign requirements at the Exit Ramp, when work is proposed on the local street, see CA MUTCD Figure 6H-22 to 6H-27.

LEGEND

- TRAFFIC CONE
- TRAFFIC CONE (OPTIONAL TAPER)
- † TEMPORARY TRAFFIC CONTROL SIGN
- ◆◆◆◆ FLASHING ARROW SIGN (FAS)
- ☉ FAS SUPPORT OR TRAILER
- ⚡ PORTABLE FLASHING BEACON

SIGN PANEL SIZE (Min)

A	48" x 48"
B	72" x 60"
C	36" x 30"

STATE OF CALIFORNIA
DEPARTMENT OF TRANSPORTATION

TRAFFIC CONTROL SYSTEM FOR LANE CLOSURE ON FREEWAYS AND EXPRESSWAYS

NO SCALE

NOTES:

See Standard Plan T9 for tables.

Use cone spacing X for taper segment, Y for tangent segment or Z for conflict situations, as appropriate, per Table 1, unless X, Y, or Z cone spacing is shown on this sheet.

Provide at least one person to continuously maintain traffic control devices for lane closures.

Dist	COUNTY	ROUTE	POST MILES	SHEET TOTAL
			TOTAL PROJECT	No. SHEETS

Atifa Farouzi
 REGISTERED CIVIL ENGINEER
 No. CB0402
 May 31, 2018
 PLANS APPROVAL DATE
 THE STATE OF CALIFORNIA OR ITS OFFICERS OR AGENTS SHALL NOT BE RESPONSIBLE FOR THE ACCURACY OR COMPLETENESS OF SCANNED COPIES OF THIS PLAN SHEET.

TYPICAL LANE CLOSURE WITH REVERSIBLE CONTROL

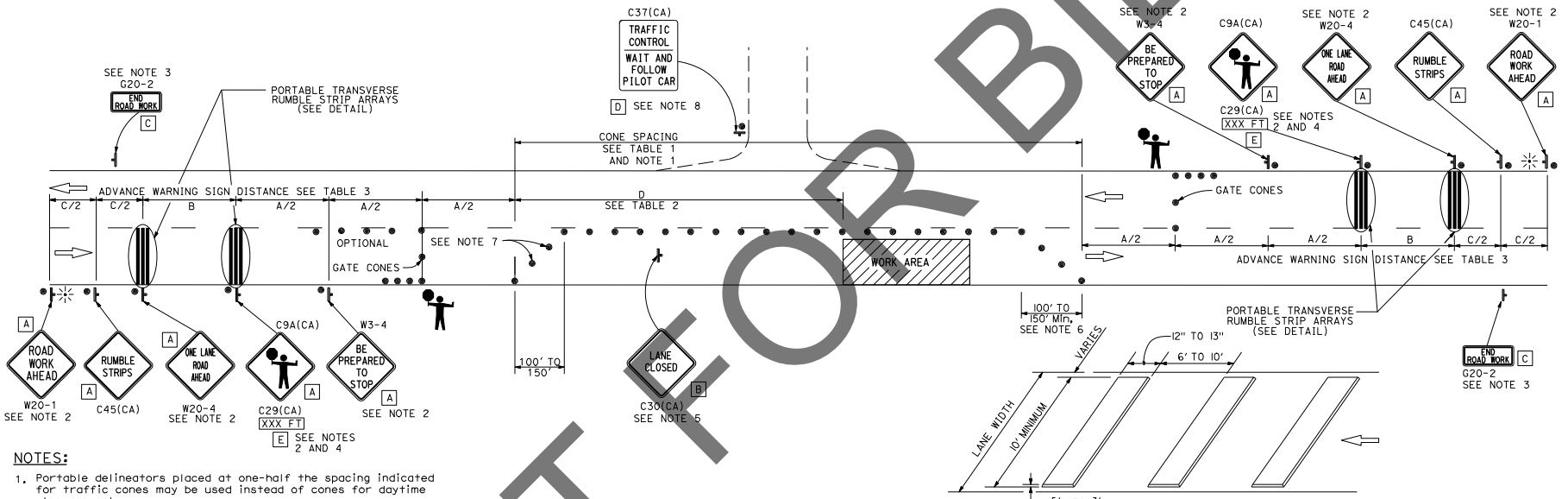

NOTES:

- Portable delineators placed at one-half the spacing indicated for traffic cones may be used instead of cones for daytime closures only.
- Each advance warning sign shall be equipped with at least two flags for daytime closure. Each flag shall be at least 16" x 16" in size and shall be orange or fluorescent red-orange in color. Flashing beacons shall be placed at the locations indicated for lane closure during hours of darkness.
- A G20-2 "END ROAD WORK" sign, shall be placed at the end of the lane closure unless the end of work area is obvious or ends within the larger project's limits.
- An optional C29(CA) sign may be placed below the C9A(CA) sign.
- Place C30(CA) "LANE CLOSED" sign at 500' to 1000' intervals throughout extended work area. They are optional if the work area is visible from the flagger station.
- Length may be reduced by the Engineer to address site conditions.
- Either traffic cones or barricades shall be placed on the taper. Barricades shall be Type I, II, or III.
- When a pilot car is used, place a C37(CA) "TRAFFIC CONTROL-WAIT AND FOLLOW PILOT CAR" sign with black legend on white background at all intersections, driveways and alleys without a flagger within the traffic control area.

LEGEND

- TRAFFIC CONE
- † TEMPORARY TRAFFIC CONTROL SIGN
- ⚡ PORTABLE FLASHING BEACON
- 🚧 FLAGGER

**STATE OF CALIFORNIA
DEPARTMENT OF TRANSPORTATION**

**TRAFFIC CONTROL SYSTEM
FOR LANE CLOSURE ON
TWO LANE CONVENTIONAL
HIGHWAYS**

NO SCALE

SIGN PANEL SIZE (Min)

A	48" x 48"
B	30" x 30"
C	36" x 18"
D	36" x 42"
E	20" x 7"

T13

2018 STANDARD PLAN T13

291

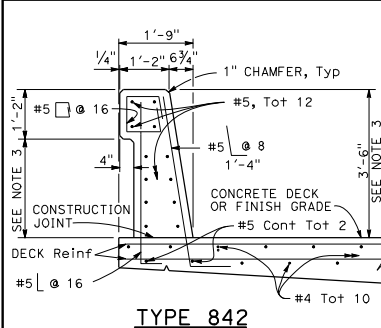

TYPE 842

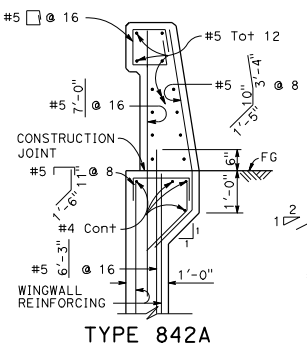

TYPE 842A

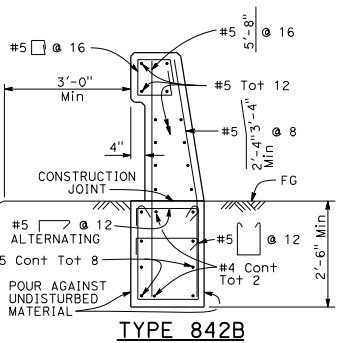

TYPE 842B

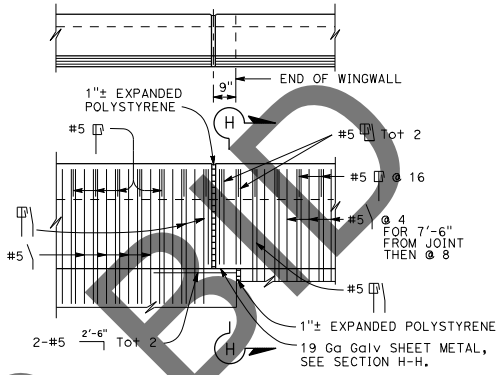

TYPE 842A TYPE 842B

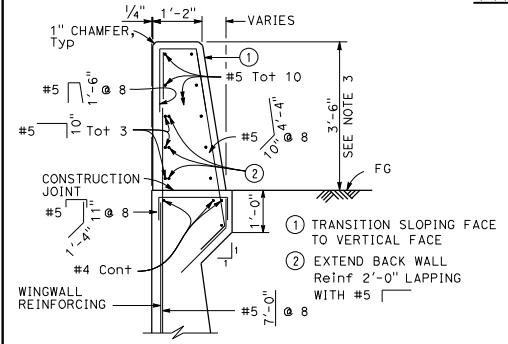

SECTION A-A

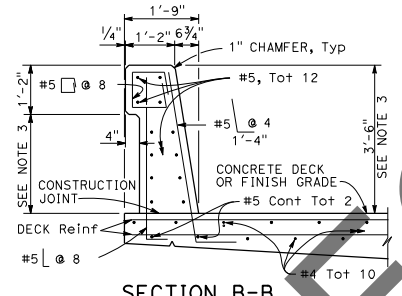

SECTION B-B

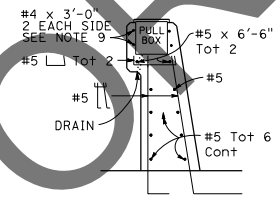

SECTION C-C

NOTE:
Types 842A & 842B are similar to Type 842 except as noted

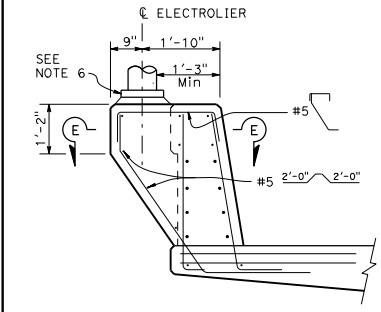

**PEDESTAL ELEVATION
SECTION D-D**

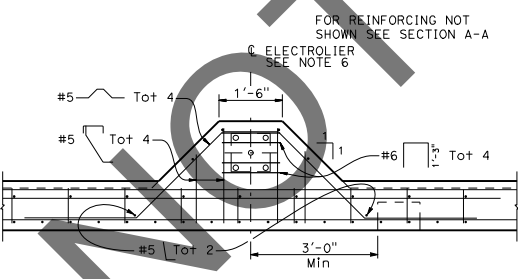

SECTION E-E

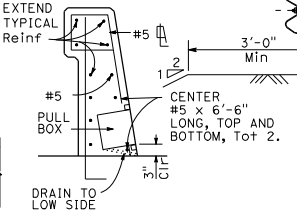

SECTION F-F

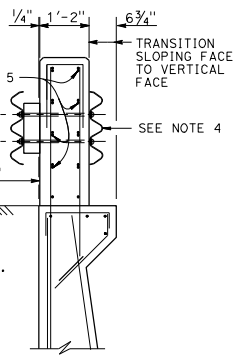

SECTION G-G

DIST	COUNTY	ROUTE	POST MILES TOTAL PROJECT	SHEET TOTAL SHEETS

REGISTERED CIVIL ENGINEER
October 19, 2018
PLANS APPROVAL DATE
No. C42892
Exp. 3-31-20
Tillett Satter
PROFESSIONAL ENGINEER
STATE OF CALIFORNIA

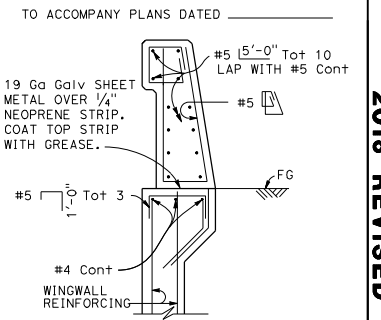

SECTION H-H

NOTES:

1. Walls are to be backfilled before barrier is placed.
2. Clearance to reinforcing steel in barrier to be 2", except as noted. Longitudinal reinforcement to stop at all expansion joints.
3. Dimensions may vary with roadway cross slope and with certain thickness of surfacing. See "ROADWAY PLANS."
4. For typical metal railing connection details not shown, see Standard Plans A77U1 and A77U2.
5. See Standard Plans ES-9A, ES-9B, ES-9C, ES-9D, and ES-9E for electrical details. The maximum number of conduits in the barrier is limited to two 2" conduits along with one 3" conduit. When a 3" conduit is used, it is restricted to the base of the barrier.
6. For electrolier mounting details, See Standard Plans ES-6A and ES-6B.
7. Minimum concrete edge distance, to the reinforcing shown, shall be maintained. Edge distance may be adjusted to accommodate increase in concrete cover for architectural treatment.
8. Taper the top of the end of the bridge railing at 4:1 to match the top elevation of the thrie beam rail element.
9. In front and back of pullbox (SECTION C-C) the #4 x 3'-0" bar must be centered so that extend minimum 8" beyond ends of pullbox. As an alternative, may substitute 4 x 4 - W12 x W12 welded fabric extending minimum 8" beyond ends of pullbox.

STATE OF CALIFORNIA
DEPARTMENT OF TRANSPORTATION
**CONCRETE BARRIER TYPE 842
DETAILS No. 2**
NO SCALE

RSP B11-82 DATED OCTOBER 19, 2018 SUPPLEMENTS THE STANDARD PLANS BOOK DATED 2018.

REVISED STANDARD PLAN RSP B11-82

2018 REVISED STANDARD PLAN RSP B11-82

CA MUTCD

NOT FOR BID

Figure 2A-2 (CA). Examples of Heights and Lateral Locations of Sign Installations

NOTES:

These sign positions are typical and should be considered a standard. When physical conditions require deviation from these typicals, they should be documented. When clear roadside recovery areas are provided, signs shall be placed as far from the traveled way as possible, up to 30 ft. When possible, they should be placed in protected locations.

Signs in medians shall be placed at midpoint of median, and should not be closer than 6 ft from the edge of a paved shoulder, or if none, 12 ft from the edge of the traveled way. When appropriate, signs for opposing directions shall be placed back to back.

E.T.W. = Edge of Traveled Way
 E.P.S. = Edge of Paved Shoulder

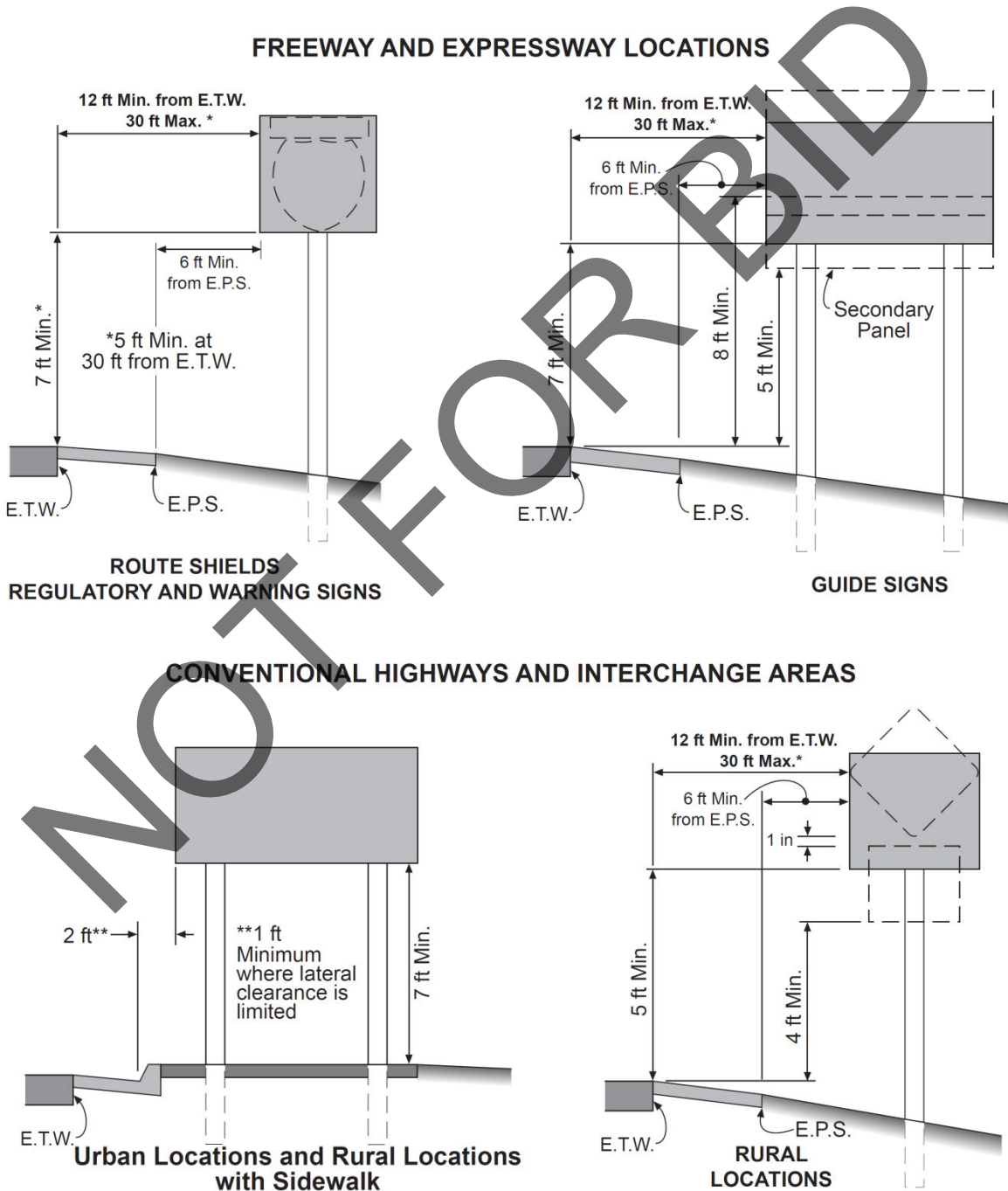
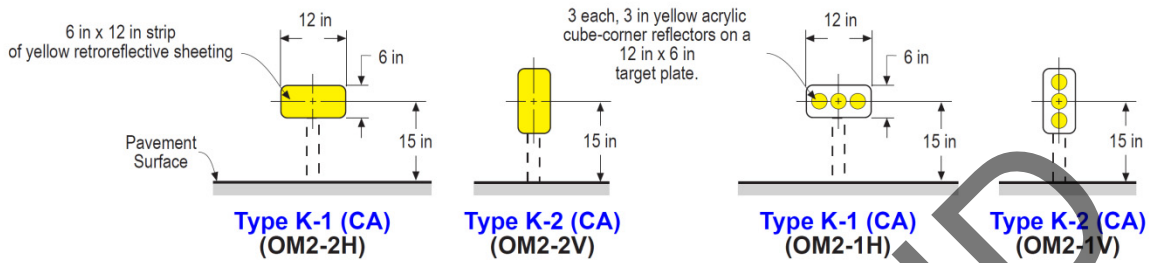
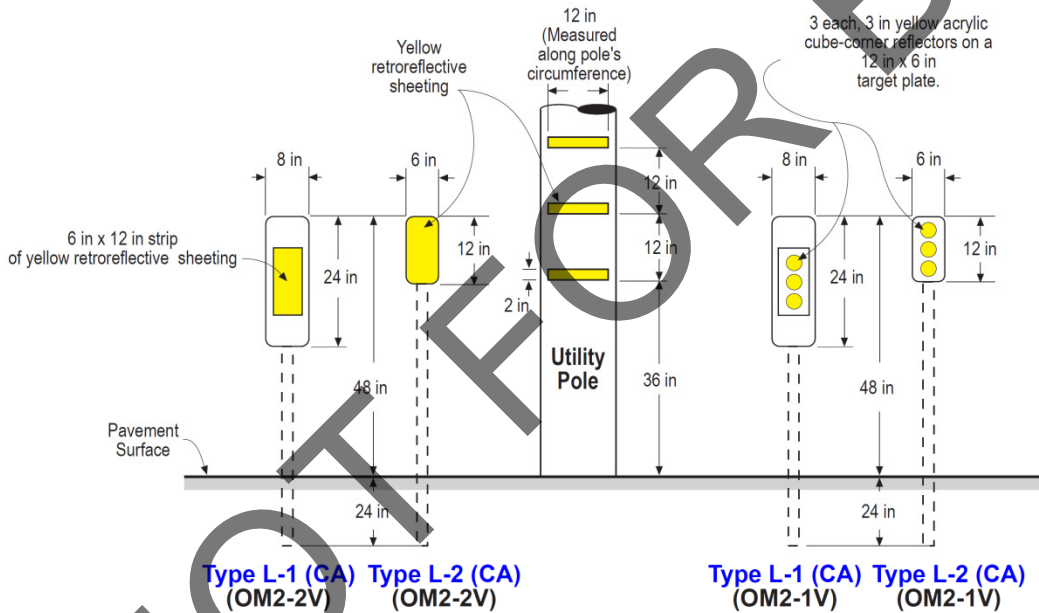

Figure 2C-13 (CA). California Object Markers (Sheet 1 of 2)

**Type K (CA) Object Marker (Type 2)
 (obstructions adjacent to the roadway)**



**Type L (CA) Object Marker (Type 2)
 (obstructions adjacent to the roadway)**



**Type N (CA) Object Marker (Type 1 or Type 4)
 (obstructions within the roadway or end of roadway)**

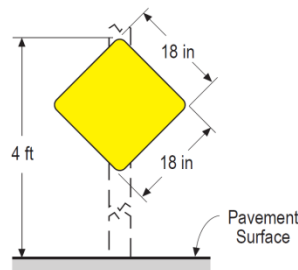

Type N-1 (CA) (OM1-3), Type N-2 (CA) (OM4-3)

NOT TO SCALE

Figure 2C-13 (CA). California Object Markers (Sheet 2 of 2)

**Type P (CA) Object Marker (Type 3)
(obstructions adjacent to the roadway)**

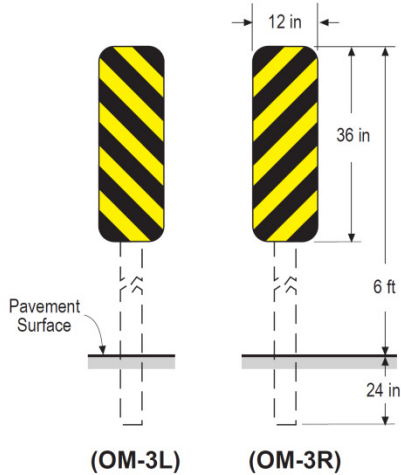

**Type Q (CA) Object Marker (Type 1)
(obstructions within the roadway)**

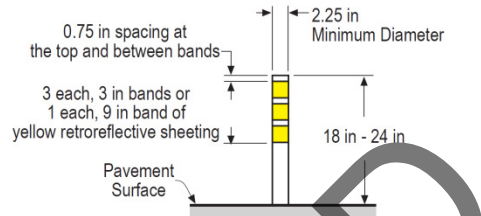

**Type R (CA) Object Marker (Type 1)
(obstructions within the roadway)**

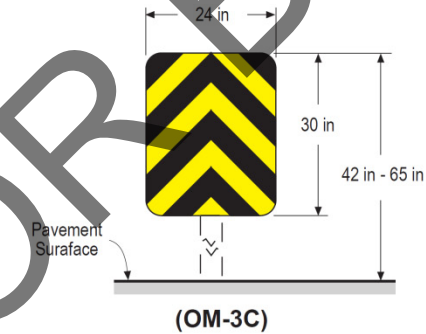

NOT TO SCALE

NOT FOR BUILDING

Option:

08 When object markers or markings are applied to an obstruction that by its nature requires a lower or higher mounting, the vertical mounting height may vary according to need.

Support:

09 Section 9B.26 contains information regarding the use of object markers on shared-use paths.

Section 2C.64 Object Markers for Obstructions Within the Roadway

Standard:

01 **Obstructions within the roadway shall be marked with a Type 1 or Type 3 object marker. In addition to markers on the face of the obstruction, warning of approach to the obstruction shall be given by appropriate pavement markings (see Section 3B.10).**

Option:

02 To provide additional emphasis, a Type 1 or Type 3 object marker may be installed at or near the approach end of a median island.

03 To provide additional emphasis, large surfaces such as bridge piers may be painted with diagonal stripes, 12 inches or greater in width, similar in design to the Type 3 object marker.

Standard:

04 **The alternating black and retroreflective yellow stripes (OM3-L, OM3-R) shall be sloped down at an angle of 45 degrees toward the side on which traffic is to pass the obstruction. If traffic can pass to either side of the obstruction, the alternating black and retroreflective yellow stripes (OM3-C) shall form chevrons that point upwards.**

Option:

05 Appropriate signs (see Sections 2B.32 and 2C.25) directing traffic to one or both sides of the obstruction may be used instead of the object marker.

06 Objects in a paved area within 8 feet of the traveled way may be marked with a Type P(CA) (OM-3L, OM-3R) or Type R(CA) (OM-3C) object marker.

07 The Type Q(CA) object marker may be used to emphasize objects within the roadway, for example, curb noses, where it is desirable that the marker be visible from all directions.

Guidance:

08 *If any object marker is located behind the guard rail, all of the marker panel should be visible to approaching traffic.*

09 *The Type P(CA) (OM-3L, OM-3R) object marker should be in line with the inner edge of the obstruction.*

Section 2C.65 Object Markers for Obstructions Adjacent to the Roadway

Support:

01 Obstructions not actually within the roadway are sometimes so close to the edge of the road that they need a marker. These include underpass piers, bridge abutments, handrails, ends of traffic barriers, utility poles, and culvert headwalls. In other cases there might not be a physical object involved, but other roadside conditions exist, such as narrow shoulders, drop-offs, gores, small islands, and abrupt changes in the roadway alignment, that might make it undesirable for a road user to leave the roadway, and therefore would create a need for a marker.

Standard:

02 **If a Type 2 or Type 3 object marker is used to mark an obstruction adjacent to the roadway, the edge of the object marker that is closest to the road user shall be installed in line with the closest edge of the obstruction.**

03 **Where Type 3 object markers are applied to the approach ends of guardrail and other roadside appurtenances-appurtenances, sheeting without a substrate shall be directly affixed to the approach end of the guardrail in a rectangular shape conforming to the size of the approach end of the guardrail with alternating black and retroreflective yellow stripes sloping downward at a angle of 45 degrees toward the side of the obstruction on which traffic is to pass.**

04 **Type 1 and Type 4 object markers shall not be used to mark obstructions adjacent to the roadway.**

Guidance:

05 *Standard warning signs in this Chapter should also be used where applicable.*

Option:

06 Objects outside of the paved shoulder, within 12 feet of the traveled way, may be marked with Type L(CA) object markers.

07 The Type L(CA) (OM2-2V and OM2-2H) object markers may be placed in front of, alongside of, or attached to the object. Where objects are very close to each other, only the first object may need to be marked.

08 The Type L(CA) Utility Pole marker may be used to mark a utility pole.

Standard:

09 **If used on State highways, Type L-1(CA) (OM2-2V) object marker shall be used instead of Type L-2(CA) (OM2-2V).**

Guidance:

10 *If used, the utility company should be responsible for installing and maintaining the Type L(CA) Utility Pole marker.*

Support:

11 See Section 2C.12 and 2C.47 for use of Type N-1(CA) (OM1-3) object markers in conjunction with One-Directional Large Arrow (W1-6) and Two-Direction Large Arrow (W1-7) signs for abrupt changes in the roadway alignment.

12 See Section 6F.105(CA) for use of Type N(CA), P(CA) and R(CA) object markers for temporary traffic control.

Option:

13 If engineering judgment indicates that the exit gore at an interchange cannot be negotiated in a reasonable manner, then in addition to the Type F and G delineators, Type R(CA) (OM-3C) object marker may be used as shown in Figure 3F-102(CA).

Section 2C.66 Object Markers for Ends of Roadways

Support:

01 The Type 4 object marker is used to warn and alert road users of the end of a roadway in other than construction or maintenance areas.

Standard:

02 **If an object marker is used to mark the end of a roadway, a Type 4 object marker shall be used.**

Option:

03 The Type 4 object marker may be used in instances where there are no alternate vehicular paths.

Standard:

03a **The end-of-roadway marker shall be used at the end of a road or cul-de-sac street where there is no alternate vehicular path.**

04 Where conditions warrant, more than one marker, or a larger marker with or without a Type 3 Barricade (see Section 2B.67), may be used at the end of the roadway.

Standard:

05 ~~The minimum mounting height, measured vertically from the bottom of a Type 4 object marker to the elevation of the near edge of the traveled way, shall be 4 feet.~~

05a **Figure 2C-13(CA) shall be used for mounting height of the end-of-the-roadway marker.**

Guidance:

06 *Appropriate advance warning signs in this Chapter should be used.*

Support:

07 See Section 2C.26 for use of end-of-roadway marker in conjunction with END (W31(CA)) sign.

*Prevailing Wages
(Blue Pages)*

inserted here

NOT FOR BID

LIST OF PREVAILING WAGES (BLUE PAGES)

Prevailing Wage Determination

Liquidated Damages

NOT FOR BID

Index 2024-1 Southern California basic trade journeyman rates

General prevailing wage determinations
made by the director of industrial relations

Pursuant to California Labor Code part 7,
chapter 1, article 2, sections 1770, 1773, and 1773.1

Determination	Holidays, scope of work, travel & subsistence	Predetermined increase
Asbestos Worker, Heat and Frost Insulator (d)	Select One ▼	Increase
Asbestos and Lead Abatement (Laborer) (e)	Select One ▼	Increase
Building/Construction Inspector and Field Soils and Material Tester +	Select One ▼	Increase
Carpenter	Select One ▼	Increase
Cement Mason	Select One ▼	Increase
Cranes, Pile Driver and Hoisting Equipment (Operating Engineer) +	Select One ▼	Increase
Dredger (Operating Engineer) (e)	Select One ▼	Increase
Drywall Installer (Carpenter)	Select One ▼	Increase
Elevator Constructor (e)	Select One ▼	Increase
Fence Builder (Carpenter) (e)	Select One ▼	Increase
Fire Safety and Miscellaneous Sealing (e) +	Select One ▼	No increase *
Gunite Worker (Laborer) (e)	Select One ▼	Increase
Horizontal Directional Drilling (Laborer)(e)	Select One ▼	Increase
Housemover (Laborer)	Select One ▼	Increase
Laborer	Select One ▼	Increase
Landfill Worker (Operating Engineer) (e)	Select One ▼	Increase

Landscape Irrigation Laborer	Select One ▼	Increase
Landscape Maintenance Laborer (e)	Select One ▼	No increase *
Landscape Operating Engineer (e)	Select One ▼	Increase
Light Fixture Maintenance	Select One ▼	No increase *
Modular Furniture Installer (Carpenter) (e)	Select One ▼	Increase
Operating Engineer +	Select One ▼	Increase
Parking and Highway Improvement (Striping, slurry & seal coat operations-Laborer) (e)	Select One ▼	Increase
Teamster +	Select One ▼	Increase
Tree Maintenance (Laborer) (e)	Select One ▼	Increase
Tunnel Worker (Laborer)	Select One ▼	Increase
Tunnel (Operating Engineer) +	Select One ▼	Increase

[Return to main table](#)

+ Includes shift pay determinations.

* A single asterisk after the expiration date of a determination indicates that no increase is required for projects advertised while that determination is in effect. The determination remains in effect until it is canceled, modified, or superseded by a new determination by the Director of Industrial Relations. A new determination will become effective 10 days after it is issued. Contact the Office of the Director - Research Unit at (415) 703-4774 after 10 days from the expiration date, if no subsequent determination is issued.

d. Includes San Diego County; excludes Mono County.

e. Includes San Diego County.

To view the above current prevailing wage determinations, current predetermined increases, and the current holiday, advisory scope of work, and travel and subsistence provisions for each craft, you must first download a free copy of the Adobe Acrobat Reader available by clicking on the icon below:



GENERAL PREVAILING WAGE DETERMINATION MADE BY THE DIRECTOR OF INDUSTRIAL RELATIONS
PURSUANT TO CALIFORNIA LABOR CODE PART 7, CHAPTER 1, ARTICLE 2, SECTIONS 1770, 1773 AND 1773.1
FOR COMMERCIAL BUILDING, HIGHWAY, HEAVY CONSTRUCTION AND DREDGING PROJECTS

Craft: Asbestos Worker, Heat and Frost Insulator #

Determination:
SC-3-5-1-2023-1

Issue Date:
August 22, 2023

Expiration date of determination:
June 30, 2024** The rate to be paid for work performed after this date has been determined. If work will extend past this date, the new rate must be paid and should be incorporated in contracts entered into now. Contact the Office of the Director - Research Unit for specific rates at (415) 703-4774.

Localities:
All localities within Imperial, Inyo, Kern, Los Angeles, Orange, Riverside, San Bernardino, San Diego, San Luis Obispo, Santa Barbara and Ventura Counties.

Wages and Employer Payments:

Classification (Journey person)	Basic Hourly Rate	Health and Welfare	Pension	Vacation and Holiday	Training	Other	Hours	Total Hourly Rate	Daily Overtime Hourly Rate (1 ½ X)	Daily Overtime Hourly Rate (2 X)	Saturday Overtime Hourly Rate (1 ½ X)	Saturday Overtime Hourly Rate (2 X)	Sunday/ Holiday Overtime Hourly Rate
Mechanic	\$52.83 ^a	\$11.78 ^b	\$8.12 ^c	\$3.98	\$1.89	\$0.00	8.0	\$78.60	\$105.015 ^d	\$131.43 ^e	\$105.015 ^f	\$131.43 ^e	\$131.43 ^g

Determination:
SC-3-5-3-2023-1

Issue Date:
August 22, 2023

Expiration date of determination:

June 30, 2024* Effective until superseded by a new determination issued by the Director of Industrial Relations. Contact the Office of the Director – Research Unit at (415) 703-4774 for the new rates after 10 days from the expiration date, if no subsequent determination is issued.

Wages and Employer Payments:

Classification	Basic Hourly Rate	Health and Welfare	Pension	Vacation and Holiday	Training	Other	Hours	Total Hourly Rate	Daily Overtime Hourly Rate (1 ½ X)	Saturday Overtime Hourly Rate (1 ½ X)	Sunday/ Holiday Overtime Hourly Rate
Hazardous Material Handler Mechanic	\$30.00 ^h	\$6.88 ⁱ	\$6.17	\$0.00	\$0.82	\$0.00	8.0	\$43.87	\$58.87	\$58.87	\$58.87 ^j

Note:

Asbestos removal workers must be trained and the work conducted according to the Code of Federal Regulations 29 CFR 1926.58, the California Labor Code 6501.5 and the California Code of Regulations, Title 8, Section 5208. Contractors must be certified by the Contractors' State License Board and registered with the Division of Occupational Safety and Health (DOSH). For further information, contact the Asbestos Contractors' Registration Unit, DOSH at (916) 574-2993.

Recognized holidays:

Holidays upon which the general prevailing hourly wage rate for Holiday work shall be paid, shall be all holidays in the collective bargaining agreement, applicable to the particular craft, classification, or type of worker employed on the project, which is on file with the Director of Industrial Relations. If the prevailing rate is not based on a collectively bargained rate, the holidays upon which the prevailing rate shall be paid shall be as provided in Section 6700 of the Government Code. You may obtain the holiday provisions for the current determinations on the [Director's General Prevailing Wage Determinations Website](http://www.dir.ca.gov/OPRL/DPreWageDetermination.htm) (http://www.dir.ca.gov/OPRL/DPreWageDetermination.htm). Holiday provisions for current or superseded determinations may be obtained by contacting the Office of the Director – Research Unit at (415) 703-4774.

Travel and/or subsistence payment:

In accordance with Labor Code Sections 1773.1 and 1773.9, contractors shall make travel and/or subsistence payments to each worker to execute the work. You may obtain the travel and/or subsistence provisions for the current determinations on the [Director's General Prevailing Wage Determinations Website](http://www.dir.ca.gov/OPRL/DPreWageDetermination.htm) (http://www.dir.ca.gov/OPRL/DPreWageDetermination.htm). Travel and/or subsistence requirements for current or superseded determinations may be obtained by contacting the Office of the Director – Research Unit at (415) 703-4774.

Indicates an apprenticeable craft. The current apprentice wage rates are available on the [Prevailing Wage Apprentice Determinations Website](http://www.dir.ca.gov/OPRL/PWAppWage/PWAppWageStart.asp) (<http://www.dir.ca.gov/OPRL/PWAppWage/PWAppWageStart.asp>).

^a Includes 5.5% of employee's gross wage for dues/service fee check-off plus \$0.25 for supplemental dues.

^b Includes \$0.01 for Occupational Health Plan.

^c Pursuant to Labor Code Sections 1773.1 and 1773.8, the amount paid for the employer payment may vary resulting in a lower taxable Basic Hourly Rate, but the Total Hourly Rates for Straight Time and Overtime may not be less than the general prevailing rate of per diem wages.

^d Rate applies to the first 2 overtime hours. Applies to all daily overtime hours on maintenance and asbestos abatement projects.

^e Rate applies to all other Daily and Saturday overtime hours.

^f Rate applies to first 8 hours worked on new construction. Applies to all Saturday hours on maintenance and asbestos abatement projects.

^g \$184.26 per hour for work on Labor Day. For maintenance and asbestos abatement projects, Sundays and observed holidays may be worked at the time and one half rate.

^h Includes 5.5% of employee's gross wage for dues/service fee check-off plus \$0.06 for supplemental dues.

ⁱ Includes \$0.40 for medical monitoring in compliance with industry regulations procedures and \$0.01 for Occupational Health Plan.

^j \$103.87 per hour for work on Labor Day.

NOT FOR BIDD

GENERAL PREVAILING WAGE DETERMINATION MADE BY THE DIRECTOR OF INDUSTRIAL RELATIONS
PURSUANT TO CALIFORNIA LABOR CODE PART 7, CHAPTER 1, ARTICLE 2, SECTIONS 1770, 1773 AND 1773.1
FOR COMMERCIAL BUILDING, HIGHWAY, HEAVY CONSTRUCTION AND DREDGING PROJECTS

Craft: Asbestos and Lead Abatement (Laborer) #

Determination:

SC-102-882-1-2024-1

Issue Date:

February 22, 2024

Expiration date of determination:

June 30, 2024** The rate to be paid for work performed after this date has been determined. If work will extend past this date, the new rate must be paid and should be incorporated in contracts entered into now. Contact the Office of the Director - Research Unit for specific rates at (415) 703-4774.

Localities:

All localities within Imperial, Inyo, Kern, Los Angeles, Mono, Orange, Riverside, San Bernardino, San Diego, San Luis Obispo, Santa Barbara and Ventura Counties.

Wages and Employer Payments:

Classification (Journey person)	Basic Hourly Rate	Health and Welfare	Pension	Vacation and Holiday ^a	Training	Other ^b	Hours	Total Hourly Rate	Daily Overtime Hourly Rate (1 ½ X)	Saturday Overtime Hourly Rate ^c (1 ½ X)	Sunday/ Holiday Overtime Hourly Rate (2 X)
Asbestos and Lead Abatement Worker	\$41.38	\$8.95	\$11.62	\$5.02	\$0.80	\$0.51	8	\$68.28	\$88.97	\$88.97	\$109.66

Note:

Asbestos Abatement must be trained and the work conducted according to the Code of Federal Regulations 29 CFR 1926.58, the California Labor Code 6501.5 and the California Code of Regulations Title 8, Section 5208. Contractors must be certified by the Contractors' State License Board and registered with the Division of Occupational Safety and Health (DOSH). For further information, contact the Asbestos Contractors Abatement Registration Unit, DOSH at (916) 574-2993.

Recognized holidays:

Holidays upon which the general prevailing hourly wage rate for Holiday work shall be paid, shall be all holidays in the collective bargaining agreement, applicable to the particular craft, classification, or type of worker employed on the project, which is on file with the Director of Industrial Relations. If the prevailing rate is not based on a collectively bargained rate, the holidays upon which the prevailing rate shall be paid shall be as provided in Section 6700 of the Government Code. You may obtain the holiday provisions for the current determinations on the

[Director's General Prevailing Wage Determinations Website](http://www.dir.ca.gov/OPRL/DPreWageDetermination.htm) (<http://www.dir.ca.gov/OPRL/DPreWageDetermination.htm>). Holiday provisions for current or superseded determinations may be obtained by contacting the Office of the Director – Research Unit at (415) 703-4774.

Travel and/or subsistence payment:

In accordance with Labor Code Sections 1773.1 and 1773.9, contractors shall make travel and/or subsistence payments to each worker to execute the work. You may obtain the travel and/or subsistence provisions for the current determinations on the [Director's General Prevailing Wage Determinations Website](http://www.dir.ca.gov/OPRL/DPreWageDetermination.htm) (<http://www.dir.ca.gov/OPRL/DPreWageDetermination.htm>). Travel and/or subsistence requirements for current or superseded determinations may be obtained by contacting the Office of the Director – Research Unit at (415) 703-4774.

Indicates an apprenticeable craft. The current apprentice wage rates are available on the [Prevailing Wage Apprentice Determinations Website](http://www.dir.ca.gov/OPRL/PWAppWage/PWAppWageStart.asp) (<http://www.dir.ca.gov/OPRL/PWAppWage/PWAppWageStart.asp>).

^a Includes an amount for supplemental dues.

^b Includes amounts for Center for Contract Compliance, Contract Administration Fund, Industry Fund, and Laborers' Trust Administrative Trust Fund.

^c Saturdays in the same work week may be worked at straight-time if the job is shut down during the normal work week due to inclement weather, or reasons beyond the control of the employer.

NOT FOR BIDDING

GENERAL PREVAILING WAGE DETERMINATION MADE BY THE DIRECTOR OF INDUSTRIAL RELATIONS
PURSUANT TO CALIFORNIA LABOR CODE PART 7, CHAPTER 1, ARTICLE 2, SECTIONS 1770, 1773 AND 1773.1
FOR COMMERCIAL BUILDING, HIGHWAY, HEAVY CONSTRUCTION AND DREDGING PROJECTS

CRAFT: BUILDING/CONSTRUCTION INSPECTOR AND FIELD SOILS AND MATERIAL TESTER#

Determination:

SC-23-63-2-2023-2D

Issue Date:

August 22, 2023

Expiration date of determination:

June 30, 2024** The rate to be paid for work performed after this date has been determined. If work will extend past this date, the new rate must be paid and should be incorporated in contracts entered into now. Contact the Office of the Director - Research Unit for specific rates at (415) 703-4774.

Localities:

All localities within Imperial, Inyo, Kern, Los Angeles, Mono, Orange, Riverside, San Bernardino, San Luis Obispo, Santa Barbara and Ventura Counties.

Wages and Employer Payments:

Classification ^a (Journeyman)	Basic Hourly Rate	Health and Welfare	Pension ^b	Vacation and Holiday ^c	Training	Other	Hours	Total Hourly Rate	Daily Overtime Hourly Rate ^d (1½ x)	Saturday Overtime Hourly Rate ^e (1½ x)	Sunday/ Holiday Overtime Hourly Rate (2 x)
Group 1	\$56.68	\$12.85	\$14.65	\$3.85	\$1.05	\$0.41	8	\$89.49	\$117.830	\$117.830	\$146.170
Group 2	\$58.46	\$12.85	\$14.65	\$3.85	\$1.05	\$0.41	8	\$91.27	\$120.500	\$120.500	\$149.730
Group 3	\$60.46	\$12.85	\$14.65	\$3.85	\$1.05	\$0.41	8	\$93.27	\$123.500	\$123.500	\$153.730

GENERAL PREVAILING WAGE DETERMINATION MADE BY THE DIRECTOR OF INDUSTRIAL RELATIONS
PURSUANT TO CALIFORNIA LABOR CODE PART 7, CHAPTER 1, ARTICLE 2, SECTIONS 1770, 1773 AND 1773.1
FOR COMMERCIAL BUILDING, HIGHWAY, HEAVY CONSTRUCTION AND DREDGING PROJECTS

**CRAFT: BUILDING/CONSTRUCTION INSPECTOR AND FIELD SOILS AND MATERIAL TESTER#
(SPECIAL SHIFT)**

Determination:

SC-23-63-2-2023-2D

Issue Date:

August 22, 2023

Expiration date of determination:

June 30, 2024** The rate to be paid for work performed after this date has been determined. If work will extend past this date, the new rate must be paid and should be incorporated in contracts entered into now. Contact the Office of the Director - Research Unit for specific rates at (415) 703-4774.

Localities:

All localities within Imperial, Inyo, Kern, Los Angeles, Mono, Orange, Riverside, San Bernardino, San Luis Obispo, Santa Barbara and Ventura Counties.

Wages and Employer Payments:

Classification ^a (Journeyman)	Basic Hourly Rate	Health and Welfare	Pension ^b	Vacation and Holiday ^c	Training	Other	Hours	Total Hourly Rate	Daily Overtime Hourly Rate ^d (1½ x)	Saturday Overtime Hourly Rate ^e (1½ x)	Sunday/Holiday Overtime Hourly Rate (2 x)
Group 1	\$57.68	\$12.85	\$14.65	\$3.85	\$1.05	\$0.41	8	\$90.49	\$119.330	\$119.330	\$148.170
Group 2	\$59.46	\$12.85	\$14.65	\$3.85	\$1.05	\$0.41	8	\$92.27	\$122.000	\$122.000	\$151.730
Group 3	\$61.46	\$12.85	\$14.65	\$3.85	\$1.05	\$0.41	8	\$94.27	\$125.000	\$125.000	\$155.730

GENERAL PREVAILING WAGE DETERMINATION MADE BY THE DIRECTOR OF INDUSTRIAL RELATIONS
PURSUANT TO CALIFORNIA LABOR CODE PART 7, CHAPTER 1, ARTICLE 2, SECTIONS 1770, 1773 AND 1773.1
FOR COMMERCIAL BUILDING, HIGHWAY, HEAVY CONSTRUCTION AND DREDGING PROJECTS

**CRAFT: BUILDING/CONSTRUCTION INSPECTOR AND FIELD SOILS AND MATERIAL TESTER #
(MULTI-SHIFT)**

Determination:
SC-23-63-2-2023-2D

Issue Date:
August 22, 2023

Expiration date of determination:
June 30, 2024**The rate to be paid for work performed after this date has been determined. If work will extend past this date, the new rate must be paid and should be incorporated in contracts entered into now. Contact the Office of the Director - Research Unit for specific rates at (415) 703-4774.

Localities:
All localities within Imperial, Inyo, Kern, Los Angeles, Mono, Orange, Riverside, San Bernardino, San Luis Obispo, Santa Barbara and Ventura Counties.

Wages and Employer Payments:

Classification ^a (Journeyman)	Basic Hourly Rate	Health and Welfare	Pension ^b	Vacation and Holiday ^c	Training	Other	Hours ^f	Total Hourly Rate	Daily Overtime Hourly Rate ^d (1½ x)	Saturday Overtime Hourly Rate ^e (1½ x)	Sunday/Holiday Overtime Hourly Rate (2 x)
Group 1	\$57.68	\$12.85	\$14.65	\$3.85	\$1.05	\$0.41	8	\$90.49	\$119.330	\$119.330	\$148.170
Group 2	\$59.46	\$12.85	\$14.65	\$3.85	\$1.05	\$0.41	8	\$92.27	\$122.000	\$122.000	\$151.730
Group 3	\$61.46	\$12.85	\$14.65	\$3.85	\$1.05	\$0.41	8	\$94.27	\$125.000	\$125.000	\$155.730

Recognized holidays:
Holidays upon which the general prevailing hourly wage rate for Holiday work shall be paid, shall be all holidays in the collective bargaining agreement, applicable to the particular craft, classification, or type of worker employed on the project, which is on file with the Director of Industrial Relations. If the prevailing rate is not based on a collectively bargained rate, the holidays upon which the prevailing rate shall be paid shall be as provided in Section 6700 of the Government Code. You may obtain the holiday provisions for the current determinations on the [Director's General Prevailing Wage Determinations Website](http://www.dir.ca.gov/OPRL/DPreWageDetermination.htm) (http://www.dir.ca.gov/OPRL/DPreWageDetermination.htm). Holiday provisions for current or superseded determinations may be obtained by contacting the Office of the Director – Research Unit at (415) 703-4774.

Travel and/or subsistence payment:

In accordance with Labor Code Sections 1773.1 and 1773.9, contractors shall make travel and/or subsistence payments to each worker to execute the work. You may obtain the travel and/or subsistence provisions for the current determinations on the [Director's General Prevailing Wage Determinations Website](http://www.dir.ca.gov/OPRL/DPreWageDetermination.htm) (<http://www.dir.ca.gov/OPRL/DPreWageDetermination.htm>). Travel and/or subsistence requirements for current or superseded determinations may be obtained by contacting the Office of the Director – Research Unit at (415) 703-4774.

Classifications:

Group 1

- Field Soils and Materials Tester
- Field Asphaltic Concrete (Soils and Materials Tester)
- Field Earthwork (Grading Excavation and Filling)
- Roof Inspector
- Water Proofer

Group 2

- AWS-CWI Welding Inspector
- Building/Construction Inspector
- Licensed Grading Inspector
- Reinforcing Steel
- Reinforced Concrete
- Pre-Tension Concrete

- Post-Tension Concrete
- Structural Steel and Welding Inspector
- Glue-Lam and truss Joints
- Truss-Type Joint Construction
- Shear Wall and Floor System used as diaphragms
- Concrete batch Plant
- Spray-Applied Fireproofing
- Structural masonry

Group 3

- Nondestructive Testing (NDT)
- Unmanned Aircraft Systems (UAS Drones) Operator (when used in conjunction with field soils and material testing – building/construction inspection)

Indicates an apprenticeable craft. The current apprentice wage rates are available on the [Prevailing Wage Apprentice Determinations Website](http://www.dir.ca.gov/OPRL/PWAppWage/PWAppWageStart.asp) (<http://www.dir.ca.gov/OPRL/PWAppWage/PWAppWageStart.asp>).

^a For classifications within each group, see Page 4.

^b Includes an amount for Annuity.

^c Includes an amount withheld for supplemental dues.

^d Rate applies to the first 4 overtime hours. All other daily overtime is paid at the Sunday rate.

^e Rate applies to the first 12 hours worked. All other time is paid at the Sunday rate.

^f The Third Shift shall work 6.5 hours, exclusive of meal period, for which 8 hours straight-time shall be paid at the non-shift rate, Monday through Friday.

GENERAL PREVAILING WAGE DETERMINATION MADE BY THE DIRECTOR OF INDUSTRIAL RELATIONS
PURSUANT TO CALIFORNIA LABOR CODE PART 7, CHAPTER 1, ARTICLE 2, SECTIONS 1770, 1773 AND 1773.1
FOR COMMERCIAL BUILDING, HIGHWAY, HEAVY CONSTRUCTION AND DREDGING PROJECTS

Craft: Carpenter and Related Trades[#]

Determination:

SC-23-31-2-2024-1

Issue Date:

February 22, 2024

Expiration date of determination:

June 30, 2024** The rate to be paid for work performed after this date has been determined. If work will extend past this date, the new rate must be paid and should be incorporated in contracts entered into now. Contact the Office of the Director - Research Unit for specific rates at (415) 703-4774.

Localities:

All localities within Imperial, Inyo, Kern, Los Angeles, Mono, Orange, Riverside, San Bernardino, San Luis Obispo, Santa Barbara, and Ventura counties.

Wages and Employer Payments:

Classification (Journeyman)	Basic Hourly Rate	Health and Welfare	Pension	Vacation and Holiday ^a	Training	Other ^b	Hours	Total Hourly Rate	Daily Overtime Hourly Rate (1 ½ X) ^c	Saturday Overtime Hourly Rate (1 ½ X) ^d	Sunday/ Holiday Overtime Hourly Rate (2 X)
Carpenter ^{e f} , Cabinet Installer, Insulation Installer, Hardwood Floor Worker, Acoustical Installer	\$48.86	\$8.25	\$5.91	\$7.39	\$0.72	\$3.44	8.0	\$74.57	\$99.00	\$99.00	\$123.43
Pile Driverman ^g , Derrick Bargeman, Rockslinger, Bridge or Dock Carpenter, Cable Splicer	\$48.99	\$8.25	\$5.91	\$7.39	\$0.72	\$3.49	8.0	\$74.75	\$99.245	\$99.245	\$123.74
Bridge Carpenter ^e	\$48.99	\$8.25	\$5.91	\$7.39	\$0.72	\$3.44	8.0	\$74.70	\$99.195	\$99.195	\$123.69
Shingler ^e	\$48.99	\$8.25	\$5.91	\$7.39	\$0.72	\$3.44	8.0	\$74.70	\$99.195	\$99.195	\$123.69
Saw Filer	\$48.95	\$8.25	\$5.91	\$7.39	\$0.72	\$3.44	8.0	\$74.66	\$99.135	\$99.135	\$123.61
Table Power Saw Operator	\$48.96	\$8.25	\$5.91	\$7.39	\$0.72	\$3.44	8.0	\$74.67	\$99.15	\$99.15	\$123.63
Pneumatic Nailer or Power Stapler	\$49.11	\$8.25	\$5.91	\$7.39	\$0.72	\$3.44	8.0	\$74.82	\$99.375	\$99.375	\$123.93

Classification (Journeyman)	Basic Hourly Rate	Health and Welfare	Pension	Vacation and Holiday ^a	Training	Other ^b	Hours	Total Hourly Rate	Daily Overtime Hourly Rate (1 ½ X) ^c	Saturday Overtime Hourly Rate (1 ½ X) ^d	Sunday/ Holiday Overtime Hourly Rate (2 X)
Roof Loader of Shingles	\$34.20	\$8.25	\$5.91	\$7.39	\$0.72	\$3.44	8.0	\$59.91	\$77.01	\$77.01	\$94.11
Scaffold Builder	\$40.77	\$8.25	\$5.91	\$7.43	\$0.72	\$2.94	8.0	\$66.02	\$86.405	\$86.405	\$106.79
Millwright ^e	\$49.36	\$8.25	\$5.91	\$7.39	\$0.72	\$3.64	8.0	\$75.27	\$99.95	\$99.95	\$124.63
Head Rockslinger	\$49.09	\$8.25	\$5.91	\$7.39	\$0.72	\$3.44	8.0	\$74.80	\$99.345	\$99.345	\$123.89
Rock Bargeman or Scowman	\$48.89	\$8.25	\$5.91	\$7.39	\$0.72	\$3.44	8.0	\$74.60	\$99.045	\$99.045	\$123.49
Diver, Wet (Up To 50 Ft. Depth) ^h	\$105.98 ⁱ	\$8.25	\$5.91	\$7.39	\$0.72	\$3.44	8.0	\$131.69	\$184.68	\$184.68	\$237.67
Diver, (Stand-By) ^h	\$52.99 ⁱ	\$8.25	\$5.91	\$7.39	\$0.72	\$3.44	8.0	\$78.70	\$105.195	\$105.195	\$131.69
Diver's Tender ^h	\$51.99	\$8.25	\$5.91	\$7.39	\$0.72	\$3.44	8.0	\$77.70	\$103.695	\$103.695	\$129.69
Assistant Tender (Diver's) ^h	\$48.99	\$8.25	\$5.91	\$7.39	\$0.72	\$3.44	8.0	\$74.70	\$99.195	\$99.195	\$123.69

Determination:
SC-31-741-1-2023-1

Issue Date:
August 22, 2023

Expiration date of determination:
May 31, 2024* Effective until superseded by a new determination issued by the Director of Industrial Relations. Contact the Office of the Director – Research Unit at (415) 703-4774 for the new rates after ten days after the expiration date if no subsequent determination is issued.

Wages and Employer Payments:

Classification (Journeyman)	Basic Hourly Rate	Health and Welfare	Pension	Vacation and Holiday ^a	Training	Hours	Total Hourly Rate	Daily Overtime Hourly Rate (1 ½ X)	Saturday Overtime Hourly Rate (1 ½ X) ^j	Holiday Overtime Hourly Rate (2 X)
Terrazzo Installer	\$44.34	\$8.25	\$5.91	\$4.69	\$0.62	8.0	\$63.81	\$85.980	85.980	108.150
Terrazzo Finisher	\$37.84	\$8.25	\$5.91	\$4.69	\$0.62	8.0	\$57.31	\$76.23	\$76.23	\$95.15

Recognized holidays:

Holidays upon which the general prevailing hourly wage rate for Holiday work shall be paid, shall be all holidays in the collective bargaining agreement, applicable to the particular craft, classification, or type of worker employed on the project, which is on file with the Director of Industrial Relations. If the prevailing rate is not based on a collectively bargained rate, the holidays upon which the prevailing rate shall be paid shall be as provided in Section 6700 of the Government Code. You may obtain the holiday provisions for the current determinations on the [Director's General Prevailing Wage Determinations Website](http://www.dir.ca.gov/OPRL/DPreWageDetermination.htm) (<http://www.dir.ca.gov/OPRL/DPreWageDetermination.htm>). Holiday provisions for current or superseded determinations may be obtained by contacting the Office of the Director – Research Unit at (415) 703-4774.

Travel and/or subsistence payment:

In accordance with Labor Code Sections 1773.1 and 1773.9, contractors shall make travel and/or subsistence payments to each worker to execute the work. You may obtain the travel and/or subsistence provisions for the current determinations on the [Director's General Prevailing Wage Determinations Website](http://www.dir.ca.gov/OPRL/DPreWageDetermination.htm) (<http://www.dir.ca.gov/OPRL/DPreWageDetermination.htm>). Travel and/or subsistence requirements for current or superseded determinations may be obtained by contacting the Office of the Director – Research Unit at (415) 703-4774.

Indicates an apprenticeable craft. The current apprentice wage rates are available on the [Prevailing Wage Apprentice Determinations Website](http://www.dir.ca.gov/OPRL/PWAppWage/PWAppWageStart.asp) (<http://www.dir.ca.gov/OPRL/PWAppWage/PWAppWageStart.asp>).

^a Includes an amount for supplemental dues.

^b Includes an amount for Annuity.

^c All overtime worked Mon - Fri shall be paid at 1 1/2 times the straight time rate for the first four (4) hours and double (2x) the straight time for work performed after twelve (12) hours.

^d First eight (8) hours worked paid at 1 1/2 times the straight time rate, all hours after that paid at double (2x) the straight time rate. Saturdays in the same work week may be worked at straight-time rates if a job is shut down during the normal work week due to inclement weather, major mechanical breakdown or lack of materials beyond the control of the Employer.

^e When performing welding work requiring certification, classification will receive an additional \$1.00 per hour.

^f A Carpenter who performs work of forming in the construction of open cut sewers or storm drains shall receive a premium of thirteen cents (\$0.13) per hour in addition to his Carpenter's scale. This premium shall apply only on an operation in which horizontal lagging is used in conjunction with Steel H-Beams driven or placed in pre-drilled holes, for that portion of a lagged trench against which concrete is poured, namely, as a substitute for back forms, which work is performed by pile drivers.

^g When performing welding work requiring certification, classification will receive an additional \$1.00 per hour. An additional \$0.50 per hour when handling or working with new pressure-treated creosote piling or timber, or driving of used pressure-treated creosote piling.

^h Shall receive a minimum of 8 hours pay for any day or part thereof.

ⁱ For specific rates over 50 ft depth, contact the Office of the Director – Research Unit. Rates for Technicians, Manifold Operators, Pressurized Submersible Operators, Remote Control Vehicle Operators, and Remote Operated Vehicle Operators, as well as rates for Pressurized Bell Diving and Saturation Diving are available upon request.

^j Saturdays in the same work week may be worked at straight-time rates if a job is shut down during the normal work week due to inclement weather, major mechanical breakdown or lack of materials beyond the control of the Employer. Work on Sunday, if it is the 7th consecutive workday, shall be paid at double (2x) the straight-time rate.

GENERAL PREVAILING WAGE DETERMINATION MADE BY THE DIRECTOR OF INDUSTRIAL RELATIONS
PURSUANT TO CALIFORNIA LABOR CODE PART 7, CHAPTER 1, ARTICLE 2, SECTIONS 1770, 1773 AND 1773.1
FOR COMMERCIAL BUILDING, HIGHWAY, HEAVY CONSTRUCTION AND DREDGING PROJECTS

Craft: Cement Mason[#]

Determination:

SC-23-203-2-2023-1

Issue Date:

August 22, 2023

Expiration date of determination:

June 30, 2024** The rate to be paid for work performed after this date has been determined. If work will extend past this date, the new rate must be paid and should be incorporated in contracts entered into now. Contact the Office of the Director - Research Unit for specific rates at (415) 703-4774.

Localities:

All localities within Imperial, Inyo, Kern, Los Angeles, Mono, Orange, Riverside, San Bernardino, San Luis Obispo, Santa Barbara, and Ventura Counties.

Wages and Employer Payments:

Classification (Journeyman)	Basic Hourly Rate	Health and Welfare	Pension	Vacation and Holiday ^a	Training	Other	Hours	Total Hourly Rate	Daily Overtime Hourly Rate (1 ½ X) ^b	Saturday Overtime Hourly Rate (1 ½ X) ^b _c	Sunday/ Holiday Overtime Hourly Rate (2 X)
Cement Mason, Curb and Gutter Machine Operator; Clary and Similar Type of Screed Operator (Cement only); Grinding Machine Operator (all types); Jackson Vibratory, Texas Screed and Similar Type Screed Operator; Scoring Machine Operator	\$44.00	\$8.50	\$10.63	\$7.34	\$0.64	\$0.24	8.0	\$71.35	\$93.35	\$93.35	\$115.35
Magnesite, magnesite-terrazzo and mastic composition, Epoxy, Urethanes and exotic coatings, Dex-O-Tex	\$44.12	\$8.50	\$10.63	\$7.34	\$0.64	\$0.24	8.0	\$71.47	\$93.53	\$93.53	\$115.59

Classification (Journey person)	Basic Hourly Rate	Health and Welfare	Pension	Vacation and Holiday ^a	Training	Other	Hours	Total Hourly Rate	Daily Overtime Hourly Rate (1 ½ X) ^b	Saturday Overtime Hourly Rate (1 ½ X) ^b _c	Sunday/ Holiday Overtime Hourly Rate (2 X)
Floating and Troweling Machine Operator	\$44.25	\$8.50	\$10.63	\$7.34	\$0.64	\$0.24	8.0	\$71.60	\$93.725	\$93.725	\$115.85

Recognized holidays:

Holidays upon which the general prevailing hourly wage rate for Holiday work shall be paid, shall be all holidays in the collective bargaining agreement, applicable to the particular craft, classification, or type of worker employed on the project, which is on file with the Director of Industrial Relations. If the prevailing rate is not based on a collectively bargained rate, the holidays upon which the prevailing rate shall be paid shall be as provided in Section 6700 of the Government Code. You may obtain the holiday provisions for the current determinations on the [Director's General Prevailing Wage Determinations Website](http://www.dir.ca.gov/OPRL/DPreWageDetermination.htm) (<http://www.dir.ca.gov/OPRL/DPreWageDetermination.htm>). Holiday provisions for current or superseded determinations may be obtained by contacting the Office of the Director – Research Unit at (415) 703-4774.

Travel and/or subsistence payment:

In accordance with Labor Code Sections 1773.1 and 1773.9, contractors shall make travel and/or subsistence payments to each worker to execute the work. You may obtain the travel and/or subsistence provisions for the current determinations on the [Director's General Prevailing Wage Determinations Website](http://www.dir.ca.gov/OPRL/DPreWageDetermination.htm) (<http://www.dir.ca.gov/OPRL/DPreWageDetermination.htm>). Travel and/or subsistence requirements for current or superseded determinations may be obtained by contacting the Office of the Director – Research Unit at (415) 703-4774.

Indicates an apprenticeable craft. The current apprentice wage rates are available on the [Prevailing Wage Apprentice Determinations Website](http://www.dir.ca.gov/OPRL/PWAppWage/PWAppWageStart.asp) (<http://www.dir.ca.gov/OPRL/PWAppWage/PWAppWageStart.asp>).

^a Includes an amount for supplemental dues.

^b Rate applies to the first 4 daily overtime hours and the first 12 hours worked on Saturday. All other time is paid at the double time (2X) rate.

^c Saturday in the same work week may be worked at straight-time rate, up to 8 hours on Saturday or when the employee has worked a total of 40 hours in the work week, if it is not reasonably possible for any individual employee on a particular job site to complete 40 hours of work on a 8 hour day, Monday through Friday, due to inclement weather or similar act of God or a situation beyond the control of the contractor.

GENERAL PREVAILING WAGE DETERMINATION MADE BY
THE DIRECTOR OF INDUSTRIAL RELATIONS PURSUANT TO CALIFORNIA LABOR CODE
PART 7, CHAPTER 1, ARTICLE 2, SECTIONS 1770, 1773 AND 1773.1
FOR COMMERCIAL BUILDING, HIGHWAY, HEAVY CONSTRUCTION AND DREDGING PROJECTS

CRAFT: CRANES, PILE DRIVER AND HOISTING EQUIPMENT (OPERATING ENGINEER) #

Determination:

SC-23-63-2-2023-2B

Issue Date:

August 22, 2023

Expiration date of determination:

June 30, 2024** The rate to be paid for work performed after this date has been determined. If work will extend past this date, the new rate must be paid and should be incorporated in contracts entered into now. Contact the Office of the Director - Research Unit for specific rates at (415) 703-4774.

Localities:

All localities within Imperial, Inyo, Kern, Los Angeles, Mono, Orange, Riverside, San Bernardino, San Luis Obispo, Santa Barbara and Ventura Counties.

Wages and total hourly rates (including employer payments):

Classification ^a (Journeyman)	Basic Hourly Rate	Hours	Total Hourly Rate	Daily Overtime Hourly Rate ^b (1½ x)	Saturday Overtime Hourly Rate ^c (1½ x)	Sunday/Holiday Overtime Hourly Rate (2 x)
Group 1	\$57.25	8	\$90.06	\$118.685	\$118.685	\$147.310
Group 2	\$58.03	8	\$90.84	\$119.855	\$119.855	\$148.870
Group 3	\$58.32	8	\$91.13	\$120.290	\$120.290	\$149.450
Group 4	\$58.46	8	\$91.27	\$120.500	\$120.500	\$149.730
Group 5	\$58.68	8	\$91.49	\$120.830	\$120.830	\$150.170
Group 6	\$58.79	8	\$91.60	\$120.995	\$120.995	\$150.390
Group 7	\$58.91	8	\$91.72	\$121.175	\$121.175	\$150.630
Group 8	\$59.08	8	\$91.89	\$121.430	\$121.430	\$150.970
Group 9	\$59.25	8	\$92.06	\$121.685	\$121.685	\$151.310
Group 10	\$60.25	8	\$93.06	\$123.185	\$123.185	\$153.310
Group 11	\$61.25	8	\$94.06	\$124.685	\$124.685	\$155.310
Group 12	\$62.25	8	\$95.06	\$126.185	\$126.185	\$157.310
Group 13	\$63.25	8	\$96.06	\$127.685	\$127.685	\$159.310

Employer Payments:

Type of Fund	Amount per Hour
Health and Welfare	\$12.85
Pension ^d	\$14.65
Vacation and Holiday ^e	\$3.85
Training	\$1.05
Other	\$0.41

GENERAL PREVAILING WAGE DETERMINATION MADE BY
THE DIRECTOR OF INDUSTRIAL RELATIONS PURSUANT TO CALIFORNIA LABOR CODE
PART 7, CHAPTER 1, ARTICLE 2, SECTIONS 1770, 1773 AND 1773.1
FOR COMMERCIAL BUILDING, HIGHWAY, HEAVY CONSTRUCTION AND DREDGING PROJECTS

**CRAFT: CRANES, PILE DRIVER AND HOISTING EQUIPMENT
(OPERATING ENGINEER, SPECIAL SHIFT) #**

Determination:

SC-23-63-2-2023-2B

Issue Date:

August 22, 2023

Expiration date of determination:

June 30, 2024** The rate to be paid for work performed after this date has been determined. If work will extend past this date, the new rate must be paid and should be incorporated in contracts entered into now. Contact the Office of the Director - Research Unit for specific rates at (415) 703-4774.

Localities:

All localities within Imperial, Inyo, Kern, Los Angeles, Mono, Orange, Riverside, San Bernardino, San Luis Obispo, Santa Barbara and Ventura Counties.

Wages and total hourly rates (including employer payments):

Classification ^a (Journeyman)	Basic Hourly Rate	Hours	Total Hourly Rate	Daily Overtime Hourly Rate ^b (1½ x)	Saturday Overtime Hourly Rate ^c (1½ x)	Sunday/Holiday Overtime Hourly Rate (2 x)
Group 1	\$58.25	8	\$91.06	\$120.185	\$120.185	\$149.310
Group 2	\$59.03	8	\$91.84	\$121.355	\$121.355	\$150.870
Group 3	\$59.32	8	\$92.13	\$121.790	\$121.790	\$151.450
Group 4	\$59.46	8	\$92.27	\$122.000	\$122.000	\$151.730
Group 5	\$59.68	8	\$92.49	\$122.330	\$122.330	\$152.170
Group 6	\$59.79	8	\$92.60	\$122.495	\$122.495	\$152.390
Group 7	\$59.91	8	\$92.72	\$122.675	\$122.675	\$152.630
Group 8	\$60.08	8	\$92.89	\$122.930	\$122.930	\$152.970
Group 9	\$60.25	8	\$93.06	\$123.185	\$123.185	\$153.310
Group 10	\$61.25	8	\$94.06	\$124.685	\$124.685	\$155.310
Group 11	\$62.25	8	\$95.06	\$126.185	\$126.185	\$157.310
Group 12	\$63.25	8	\$96.06	\$127.685	\$127.685	\$159.310
Group 13	\$64.25	8	\$97.06	\$129.185	\$129.185	\$161.310

Employer Payments:

Type of Fund	Amount per Hour
Health and Welfare	\$12.85
Pension ^d	\$14.65
Vacation and Holiday ^e	\$3.85
Training	\$1.05
Other	\$0.41

GENERAL PREVAILING WAGE DETERMINATION MADE BY
THE DIRECTOR OF INDUSTRIAL RELATIONS PURSUANT TO CALIFORNIA LABOR CODE
PART 7, CHAPTER 1, ARTICLE 2, SECTIONS 1770, 1773 AND 1773.1
FOR COMMERCIAL BUILDING, HIGHWAY, HEAVY CONSTRUCTION AND DREDGING PROJECTS

**CRAFT: CRANES, PILE DRIVER AND HOISTING EQUIPMENT
(OPERATING ENGINEER, MULTI-SHIFT) #**

Determination:

SC-23-63-2-2023-2B

Issue Date:

August 22, 2023

Expiration date of determination:

June 30, 2024**The rate to be paid for work performed after this date has been determined. If work will extend past this date, the new rate must be paid and should be incorporated in contracts entered into now. Contact the Office of the Director - Research Unit for specific rates at (415) 703-4774.

Localities:

All localities within Imperial, Inyo, Kern, Los Angeles, Mono, Orange, Riverside, San Bernardino, San Luis Obispo, Santa Barbara and Ventura Counties.

Wages and total hourly rates (including employer payments):

Classification ^a (Journey person)	Basic Hourly Rate	Hours ^f	Total Hourly Rate	Daily Overtime Hourly Rate ^b (1½ x)	Saturday Overtime Hourly Rate ^c (1½ x)	Sunday/Holiday Overtime Hourly Rate (2 x)
Group 1	\$58.25	8	\$91.06	\$120.185	\$120.185	\$149.310
Group 2	\$59.03	8	\$91.84	\$121.355	\$121.355	\$150.870
Group 3	\$59.32	8	\$92.13	\$121.790	\$121.790	\$151.450
Group 4	\$59.46	8	\$92.27	\$122.000	\$122.000	\$151.730
Group 5	\$59.68	8	\$92.49	\$122.330	\$122.330	\$152.170
Group 6	\$59.79	8	\$92.60	\$122.495	\$122.495	\$152.390
Group 7	\$59.91	8	\$92.72	\$122.675	\$122.675	\$152.630
Group 8	\$60.08	8	\$92.89	\$122.930	\$122.930	\$152.970
Group 9	\$60.25	8	\$93.06	\$123.185	\$123.185	\$153.310
Group 10	\$61.25	8	\$94.06	\$124.685	\$124.685	\$155.310
Group 11	\$62.25	8	\$95.06	\$126.185	\$126.185	\$157.310
Group 12	\$63.25	8	\$96.06	\$127.685	\$127.685	\$159.310
Group 13	\$64.25	8	\$97.06	\$129.185	\$129.185	\$161.310

Employer Payments:

Type of Fund	Amount per Hour
Health and Welfare	\$12.85
Pension ^d	\$14.65
Vacation and Holiday ^e	\$3.85
Training	\$1.05
Other	\$0.41

Recognized holidays:

Holidays upon which the general prevailing hourly wage rate for Holiday work shall be paid, shall be all holidays in the collective bargaining agreement, applicable to the particular craft, classification, or type of worker employed on the project, which is on file with the Director of Industrial Relations. If the prevailing rate is not based on a collectively bargained rate, the holidays upon which the prevailing rate shall be paid shall be as provided in Section 6700 of the Government Code. You may obtain the holiday provisions for the current determinations on the [Director's General Prevailing Wage Determinations Website](http://www.dir.ca.gov/OPRL/DPreWageDetermination.htm) (<http://www.dir.ca.gov/OPRL/DPreWageDetermination.htm>). Holiday provisions for current or superseded determinations may be obtained by contacting the Office of the Director – Research Unit at (415) 703-4774.

Travel and/or subsistence payment:

In accordance with Labor Code Sections 1773.1 and 1773.9, contractors shall make travel and/or subsistence payments to each worker to execute the work. You may obtain the travel and/or subsistence provisions for the current determinations on the [Director's General Prevailing Wage Determinations Website](http://www.dir.ca.gov/OPRL/DPreWageDetermination.htm) (<http://www.dir.ca.gov/OPRL/DPreWageDetermination.htm>). Travel and/or subsistence requirements for current or superseded determinations may be obtained by contacting the Office of the Director – Research Unit at (415) 703-4774.

Classifications:

Group 1

Engineer Oiler

Group 2

Truck Crane Oiler

Group 3

A-Frame or Winch Truck Operator
Ross Carrier Operator (Jobsite)

Group 4

Bridge-Type Unloader and Turntable Operator
Helicopter Hoist Operator
Ojjo Earth Truss Driver Machine Operator or similar types
Snobble Unit (pin-n-go or similar type)

Group 5

Hydraulic Boom Truck/Knuckleboom
Stinger Crane (Austin-Western or similar type)
Tugger Hoist Operator (1 drum)

Group 6

Bridge Crane Operator
Cretor Crane Operator
Hoist Operator (Chicago Boom and similar type)
Lift Mobile Operator
Lift Slab Machine Operator (Vagtborg and similar types)
Material Hoist and/or Manlift Operator
Polar Gantry Crane Operator
Prentice Self-Loader
Self Climbing Scaffold (or similar type)

Shovel, Dragline, Clamshell Operator (over ¾ yd and up to 5 cu yds, M.R.C.)

Silent Piler

Tugger Hoist Operator (2 drum)

Group 7

Pedestal Crane Operator
Shovel, Dragline, Clamshell Operator (over 5 cu yds, M.R.C.)
Tower Crane Repairman
Tugger Hoist Operator (3 drum)

Group 8

Crane Operator (up to and including 25 ton capacity)
Crawler Transporter Operator
Derrick Barge Operator (up to and including 25 ton capacity)
Hoist Operator, Stiff Legs, Guy Derrick or similar type (up to and including 25 ton capacity)
Rotational Telehandler Operator
Self-Propelled Modular Transporter (Schuerle, Goldhofer or similar types)
Shovel, Dragline, Clamshell Operator (over 7 cu yds M.R.C.)

Group 9

Crane Operator (over 25 tons, up to and including 50 ton M.R.C.)
Derrick Barge Operator (over 25 tons, up to and including 50 ton M.R.C.)
Highline Cableway Operator

Hoist Operator, Stiff Legs, Guy Derrick or similar type (over 25 tons, up to and including 50 ton M.R.C.)

K-Crane

Polar Crane Operator

Self Erecting Tower Crane Operator Maximum Lifting Capacity ten (10) tons

Group 10

ABI/IFundex Machine

Crane Operator (over 50 tons, up to and including 100 ton M.R.C.)

Derrick Barge Operator (over 50 tons, up to and including 100 ton M.R.C.)

Hoist Operator, Stiff Legs, Guy Derrick or similar type (over 50 tons, up to and including 100 ton M.R.C.)

Mobile Tower Crane Operator (over 50 tons, up to and including 100 ton M.R.C.)

Shovel, Dragline, Clamshell Operator (over 10 cu. yds.)

Group 11

Crane Operator (over 100 tons, up to and including 200 ton M.R.C.)

Derrick Barge Operator (over 100 tons, up to and including 200 ton M.R.C.)

Hoist Operator, Stiff Legs, Guy Derrick or similar type (over 100 tons, up to and including 200 ton M.R.C.)

Mobile Tower Crane Operator (over 100 tons, up to and including 200 ton M.R.C.)

Tower Crane Operator and Tower Gantry

Group 12

Crane Operator (over 200 tons, up to and including 300 ton M.R.C.)

Derrick Barge Operator (over 200 tons, up to and including 300 ton M.R.C.)

Hoist Operator, Stiff Legs, Guy Derrick or similar type (over 200 tons, up to and including 300 ton M.R.C.)

Mobile Tower Crane Operator (over 200 tons, up to and including 300 ton M.R.C.)

Group 13

Crane Operator (over 300 tons)

Derrick Barge Operator (over 300 tons)

Helicopter Pilot

Hoist Operator, Stiff Legs, Guy Derrick or similar type (over 300 tons)

Hydraulically Controlled Lift Gantry Operator BCR Lift System (over 300 tons)

Mobile Tower Crane Operator (over 300 tons)

MISCELLANEOUS PROVISIONS:

1. Operators on hoists with three drums shall receive fifty cents (50¢) per hour additional pay to the regular rate of pay. The additional pay shall be added to the regular rate and become the base rate for the entire shift.
2. All heavy duty repairman and heavy duty combination shall receive one dollar (\$1.00) per hour tool allowance in addition to their regular rate of pay and this shall become their base rate of pay.
3. Employees required to suit up and work in a hazardous material environment, shall receive two dollars per hour in addition to their regular rate of pay, and that rate shall become the basic hourly rate of pay.

Indicates an apprenticeable craft. The current apprentice wage rates are available on the [Prevailing Wage Apprentice Determinations Website](http://www.dir.ca.gov/OPRL/PWAppWage/PWAppWageStart.asp) (<http://www.dir.ca.gov/OPRL/PWAppWage/PWAppWageStart.asp>).

^a For classifications within each group, see Pages 4 and 5.

^b Rate applies to the first 4 overtime hours. All other daily overtime is paid at the Sunday rate.

^c Rate applies to the first 12 hours worked. All other time is paid at the Sunday rate.

^d Includes an amount for Annuity.

^e Includes an amount withheld for supplemental dues.

^f The Third Shift shall work 6.5 hours, exclusive of meal period, for which 8 hours straight-time shall be paid at the non-shift rate, Monday through Friday.

GENERAL PREVAILING WAGE DETERMINATION MADE BY THE DIRECTOR OF INDUSTRIAL RELATIONS
PURSUANT TO CALIFORNIA LABOR CODE PART 7, CHAPTER 1, ARTICLE 2, SECTIONS 1770, 1773 AND 1773.1
FOR COMMERCIAL BUILDING, HIGHWAY, HEAVY CONSTRUCTION AND DREDGING PROJECTS

Craft: Dredger (Operating Engineer)*

Determination:

SC-63-12-23-2023-2

Issue Date:

August 22, 2023

Expiration date of determination:

July 31, 2024** The rate to be paid for work performed after this date has been determined. If work will extend past this date, the new rate must be paid and should be incorporated in contracts entered into now. Contact the Office of the Director – Research Unit for specific rates at (415) 703-4774.

Localities:

All localities within Imperial, Inyo, Kern, Los Angeles, Mono, Orange, Riverside, San Bernardino, San Diego, San Luis Obispo, Santa Barbara, and Ventura counties.

Wages and Employer Payments:

Classification	Basic Hourly Rate	Health and Welfare	Pension ^a	Vacation and Holiday ^b	Training	Other	Hours	Total Hourly Rate	Daily Overtime Hourly Rate (1 ½ X) ^c	Saturday Overtime Hourly Rate (1 ½ X) ^c	Sunday Overtime Hourly Rate (2 X)	Holiday Overtime Hourly Rate (3X)
Chief Engineer, Deck Captain	\$61.10	\$12.85	\$15.15	\$7.15	\$1.05	\$0.15	8	\$97.45	\$128.000	\$128.000	\$158.55	\$219.65
Leverman	\$64.10	\$12.85	\$15.15	\$7.15	\$1.05	\$0.15	8	\$100.45	\$132.500	\$132.500	\$164.55	\$228.65
Watch Engineer, Deckmate	\$58.02	\$12.85	\$15.15	\$7.15	\$1.05	\$0.15	8	\$94.37	\$123.380	\$123.380	\$152.39	\$210.41
Winchman (Stern Winch on Dredge)	\$57.47	\$12.85	\$15.15	\$7.15	\$1.05	\$0.15	8	\$93.82	\$122.555	\$122.555	\$151.29	\$208.76
Fireman-Oiler, Leveehand, Deckhand (can operate anchor scow under direction of mate), Bargeman	\$56.93	\$12.85	\$15.15	\$7.15	\$1.05	\$0.15	8	\$93.28	\$121.745	\$121.745	\$150.21	\$207.14

Classification	Basic Hourly Rate	Health and Welfare	Pension ^a	Vacation and Holiday ^b	Training	Other	Hours	Total Hourly Rate	Daily Overtime Hourly Rate (1 ½ X) ^c	Saturday Overtime Hourly Rate (1 ½ X) ^c	Sunday Overtime Hourly Rate (2 X)	Holiday Overtime Hourly Rate (3X)
Dozer Operator	\$58.13	\$12.85	\$15.15	\$7.15	\$1.05	\$0.15	8	\$94.48	\$123.545	\$123.545	\$152.61	\$210.74
Hydrographic Surveyor	\$59.56	\$12.85	\$15.15	\$7.15	\$1.05	\$0.15	8	\$95.91	\$125.690	\$125.690	\$155.47	\$215.03
Barge Mate	\$57.54	\$12.85	\$15.15	\$7.15	\$1.05	\$0.15	8	\$93.89	\$122.660	\$122.660	\$151.43	\$208.97
Welder	\$59.52	\$12.85	\$15.15	\$7.15	\$1.05	\$0.15	8	\$95.87	\$125.630	\$125.630	\$155.39	\$214.91

Recognized holidays:

Holidays upon which the general prevailing hourly wage rate for Holiday work shall be paid, shall be all holidays in the collective bargaining agreement, applicable to the particular craft, classification, or type of worker employed on the project, which is on file with the Director of Industrial Relations. If the prevailing rate is not based on a collectively bargained rate, the holidays upon which the prevailing rate shall be paid shall be as provided in Section 6700 of the Government Code. You may obtain the holiday provisions for the current determinations on the [Director's General Prevailing Wage Determinations Website](http://www.dir.ca.gov/OPRL/DPreWageDetermination.htm) (<http://www.dir.ca.gov/OPRL/DPreWageDetermination.htm>). Holiday provisions for current or superseded determinations may be obtained by contacting the Office of the Director – Research Unit at (415) 703-4774.

Travel and/or subsistence payment:

In accordance with Labor Code Sections 1773.1 and 1773.9, contractors shall make travel and/or subsistence payments to each worker to execute the work. You may obtain the travel and/or subsistence provisions for the current determinations on the [Director's General Prevailing Wage Determinations Website](http://www.dir.ca.gov/OPRL/DPreWageDetermination.htm) (<http://www.dir.ca.gov/OPRL/DPreWageDetermination.htm>). Travel and/or subsistence requirements for current or superseded determinations may be obtained by contacting the Office of the Director – Research Unit at (415) 703-4774.

MISCELLANEOUS PROVISION:

Employees required to suit up and work in a hazardous material environment, shall receive Two Dollars (\$2.00) per hour in addition to their regular rate of pay, and that rate shall become the basic hourly rate of pay.

Indicates an apprenticeable craft. The current apprentice wage rates are available on the [Prevailing Wage Apprentice Determinations Website](http://www.dir.ca.gov/OPRL/PWAppWage/PWAppWageStart.asp) (<http://www.dir.ca.gov/OPRL/PWAppWage/PWAppWageStart.asp>).

^a Includes an amount for annuity.

^b Includes an amount for supplemental dues.

^c Rate applies to the first 4 daily overtime hours and first 12 hours on Saturdays. All other time is paid at the Sunday overtime rate.

GENERAL PREVAILING WAGE DETERMINATION MADE BY THE DIRECTOR OF INDUSTRIAL RELATIONS
PURSUANT TO CALIFORNIA LABOR CODE PART 7, CHAPTER 1, ARTICLE 2, SECTIONS 1770, 1773 AND 1773.1
FOR COMMERCIAL BUILDING, HIGHWAY, HEAVY CONSTRUCTION AND DREDGING PROJECTS

Craft: Drywall Installer/Lather (Carpenter)#

Determination:

SC-31-X-41-2024-1

Issue Date:

February 22, 2024

Expiration date of determination:

June 30, 2024** The rate to be paid for work performed after this date has been determined. If work will extend past this date, the new rate must be paid and should be incorporated in contracts entered into now. Contact the Office of the Director - Research Unit for specific rates at (415) 703-4774.

Localities:

All localities within Imperial, Inyo, Kern, Los Angeles, Mono, Orange, Riverside, San Bernardino, San Luis Obispo, Santa Barbara and Ventura counties.

Wages and Employer Payments:

Classification (Journeyman)	Basic Hourly Rate	Health and Welfare	Pension	Vacation and Holiday ^a	Training	Other ^b	Hours	Total Hourly Rate	Daily Overtime Hourly Rate (1 ½ X) ^c	Saturday Overtime Hourly Rate (1 ½ X) ^c	Sunday/ Holiday Overtime Hourly Rate (2 X)
Drywall Installer/Lather	\$48.86	\$8.25	\$5.91	\$7.39	\$0.72	\$3.77	8.0	\$74.90	\$99.33	\$99.33	\$123.76

Determination:

SC-31-X-41-2024-1A

Issue Date:

February 22, 2024

Expiration date of determination:

June 30, 2024* Effective until superseded by a new determination issued by the Director of Industrial Relations. Contact the Office of the Director - Research Unit (415) 703-4774 for the new rates after 10 days from the expiration date, if no subsequent determination is issued.

Localities:

All localities within Imperial, Inyo, Kern, Los Angeles, Mono, Orange, Riverside, San Bernardino, San Luis Obispo, Santa Barbara and Ventura counties

Wages and Employer Payments:

Classification (Journey person)	Basic Hourly Rate	Health and Welfare	Pension	Vacation and Holiday ^a	Training	Other	Hours	Total Hourly Rate	Daily Overtime Hourly Rate (1 ½ X) ^c	Saturday Overtime Hourly Rate (1 ½ X) ^c	Sunday/ Holiday Overtime Hourly Rate (2 X)
Stocker, Scrapper	\$20.80	\$4.25	\$0.00	\$8.39	\$0.72	\$0.00	8.0	\$34.16	\$44.56	\$44.56	\$54.96

Recognized holidays:

Holidays upon which the general prevailing hourly wage rate for Holiday work shall be paid, shall be all holidays in the collective bargaining agreement, applicable to the particular craft, classification, or type of worker employed on the project, which is on file with the Director of Industrial Relations. If the prevailing rate is not based on a collectively bargained rate, the holidays upon which the prevailing rate shall be paid shall be as provided in Section 6700 of the Government Code. You may obtain the holiday provisions for the current determinations on the [Director's General Prevailing Wage Determinations Website](http://www.dir.ca.gov/OPRL/DPreWageDetermination.htm) (<http://www.dir.ca.gov/OPRL/DPreWageDetermination.htm>). Holiday provisions for current or superseded determinations may be obtained by contacting the Office of the Director – Research Unit at (415) 703-4774.

Travel and/or subsistence payment:

In accordance with Labor Code Sections 1773.1 and 1773.9, contractors shall make travel and/or subsistence payments to each worker to execute the work. You may obtain the travel and/or subsistence provisions for the current determinations on the [Director's General Prevailing Wage Determinations Website](http://www.dir.ca.gov/OPRL/DPreWageDetermination.htm) (<http://www.dir.ca.gov/OPRL/DPreWageDetermination.htm>). Travel and/or subsistence requirements for current or superseded determinations may be obtained by contacting the Office of the Director – Research Unit at (415) 703-4774.

Indicates an apprenticeable craft. The current apprentice wage rates are available on the [Prevailing Wage Apprentice Determinations Website](http://www.dir.ca.gov/OPRL/PWAppWage/PWAppWageStart.asp) (<http://www.dir.ca.gov/OPRL/PWAppWage/PWAppWageStart.asp>).

^a Includes an amount per hour worked for supplemental dues.

^b Includes an amount for Annuity.

^c Rate applies to the first 4 daily overtime hours and to the first 8 hours on Saturday. All other overtime will be paid the Sunday and Holiday double time rate. Saturdays in the same workweek may be worked at straight-time if job is shut down during the normal work week due to inclement weather.

GENERAL PREVAILING WAGE DETERMINATION MADE BY THE DIRECTOR OF INDUSTRIAL RELATIONS
PURSUANT TO CALIFORNIA LABOR CODE PART 7, CHAPTER 1, ARTICLE 2, SECTIONS 1770, 1773 AND 1773.1
FOR COMMERCIAL BUILDING, HIGHWAY, HEAVY CONSTRUCTION AND DREDGING PROJECTS

Craft: Elevator Constructor[#]

Determination:

SC-62-X-999-2024-1

Issue Date:

February 22, 2024

Expiration date of determination:

December 31, 2024** The rate to be paid for work performed after this date has been determined. If work will extend past this date, the new rate must be paid and should be incorporated in contracts entered into now. Contact the Office of the Director - Research Unit for specific rates at (415) 703-477.

Localities:

All localities within Imperial, Los Angeles, Orange, Riverside, San Diego, Santa Barbara and Ventura counties. Portions of Kern, San Bernardino and San Luis Obispo counties are detailed below ^a.

Wages and Employer Payments:

Classification (Journey person)	Basic Hourly Rate	Health and Welfare	Pension ^b	Vacation and Holiday ^c	Training	Other	Hours	Total Hourly Rate	Daily Overtime Hourly Rate (1 ½ X) ^d	Saturday Overtime Hourly Rate (1 ½ X) ^d	Sunday/ Holiday Overtime Hourly Rate
Mechanic	\$66.63	\$16.175	\$20.96	\$6.05	\$0.75	\$1.30	8.0	\$111.865	\$145.180	\$145.180	\$178.495
Mechanic (employed in industry more than 5 years)	\$66.63	\$16.175	\$20.96	\$7.39	\$0.75	\$1.30	8.0	\$113.205	\$146.520	\$146.520	\$179.835
Helper ^e	\$46.64	\$16.175	\$20.96	\$4.24	\$0.75	\$1.30	8.0	\$90.065	\$113.385	\$113.385	\$136.705
Helper (employed in industry more than 5 years) ^e	\$44.64	\$16.175	\$20.96	\$5.17	\$0.75	\$1.30	8.0	\$90.995	\$114.315	\$114.315	\$137.635

Recognized holidays:

Holidays upon which the general prevailing hourly wage rate for Holiday work shall be paid, shall be all holidays in the collective bargaining agreement, applicable to the particular craft, classification, or type of worker employed on the project, which is on file with the Director of Industrial Relations. If the prevailing rate is not based on a collectively bargained rate, the holidays upon which the prevailing rate shall be paid shall be as provided in Section 6700 of the Government Code. You may obtain the holiday provisions for the current determinations on the [Director's General Prevailing Wage Determinations Website](http://www.dir.ca.gov/OPRL/DPreWageDetermination.htm) (<http://www.dir.ca.gov/OPRL/DPreWageDetermination.htm>). Holiday provisions for current or superseded determinations may be obtained by contacting the Office of the Director – Research Unit at (415) 703-4774.

Travel and/or subsistence payment:

In accordance with Labor Code Sections 1773.1 and 1773.9, contractors shall make travel and/or subsistence payments to each worker to execute the work. You may obtain the travel and/or subsistence provisions for the current determinations on the [Director's General Prevailing Wage Determinations Website](http://www.dir.ca.gov/OPRL/DPreWageDetermination.htm) (<http://www.dir.ca.gov/OPRL/DPreWageDetermination.htm>). Travel and/or subsistence requirements for current or superseded determinations may be obtained by contacting the Office of the Director – Research Unit at (415) 703-4774.

Indicates an apprenticeable craft. The current apprentice wage rates are available on the [Prevailing Wage Apprentice Determinations Website](http://www.dir.ca.gov/OPRL/PWAppWage/PWAppWageStart.asp) (<http://www.dir.ca.gov/OPRL/PWAppWage/PWAppWageStart.asp>).

^a Applies to that portion of these counties south of the Tehachapi Line. For more information contact the Office of the Director – Research Unit.

^b Includes an amount for Annuity Trust Fund.

^c Includes an amount for 8 paid holidays.

^d For Contract Service work only. All other overtime is paid at the Sunday/Holiday rate.

^e Ratio: The total number of Helpers employed shall not exceed the number of Mechanics on any one job. When removing old and installing new cables on existing elevator installations, the Company may use two (2) Helpers, Apprentices or Assistant Mechanics to one (1) Mechanic. Two (2) Helpers, Apprentices or Assistant Mechanics to each three (3) Mechanics may be employed in Contract Service work only. For more information on the use of Helpers, contact the Office of the Director – Research Unit.

NOT FOR BIDD

GENERAL PREVAILING WAGE DETERMINATION MADE BY THE DIRECTOR OF INDUSTRIAL RELATIONS
PURSUANT TO CALIFORNIA LABOR CODE PART 7, CHAPTER 1, ARTICLE 2, SECTIONS 1770, 1773 AND 1773.1
FOR COMMERCIAL BUILDING, HIGHWAY, HEAVY CONSTRUCTION AND DREDGING PROJECTS

Craft: Fence Builder (Carpenter)#

Determination:

SC-23-31-20-2024-1

Issue Date:

February 22, 2024

Expiration date of determination:

June 30, 2024** The rate to be paid for work performed after this date has been determined. If work will extend past this date, the new rate must be paid and should be incorporated in contracts entered into now. Contact the Office of the Director - Research Unit for specific rates at (415) 703-4774.

Localities:

All localities within Imperial, Inyo, Kern, Los Angeles, Mono, Orange, Riverside, San Bernardino, San Diego, San Luis Obispo, Santa Barbara, and Ventura counties.

Wages and Employer Payments:

Classification (Journeyman)	Basic Hourly Rate	Health and Welfare	Pension	Vacation and Holiday	Training	Other ^a	Hours	Total Hourly Rate	Daily Overtime Hourly Rate (1 ½ X) ^b	Saturday Overtime Hourly Rate (1 ½ X) ^c	Sunday/ Holiday Overtime Hourly Rate
Fence Builder	\$45.29	\$8.25	\$5.75	\$7.14	\$0.67	\$2.33	8.0	\$69.43	\$92.075	\$92.075	\$114.72

Recognized holidays:

Holidays upon which the general prevailing hourly wage rate for Holiday work shall be paid, shall be all holidays in the collective bargaining agreement, applicable to the particular craft, classification, or type of worker employed on the project, which is on file with the Director of Industrial Relations. If the prevailing rate is not based on a collectively bargained rate, the holidays upon which the prevailing rate shall be paid shall be as provided in Section 6700 of the Government Code. You may obtain the holiday provisions for the current determinations on the [Director's General Prevailing Wage Determinations Website](http://www.dir.ca.gov/OPRL/DPreWageDetermination.htm) (http://www.dir.ca.gov/OPRL/DPreWageDetermination.htm). Holiday provisions for current or superseded determinations may be obtained by contacting the Office of the Director – Research Unit at (415) 703-4774.

Travel and/or subsistence payment:

In accordance with Labor Code Sections 1773.1 and 1773.9, contractors shall make travel and/or subsistence payments to each worker to execute the work. You may obtain the travel and/or subsistence provisions for the current determinations on the [Director's General Prevailing Wage Determinations Website](http://www.dir.ca.gov/OPRL/DPreWageDetermination.htm) (http://www.dir.ca.gov/OPRL/DPreWageDetermination.htm). Travel and/or subsistence requirements for current or superseded determinations may be obtained by contacting the Office of the Director – Research Unit at (415) 703-4774.

Indicates an apprenticeable craft. The current apprentice wage rates are available on the [Prevailing Wage Apprentice Determinations Website](http://www.dir.ca.gov/OPRL/PWAppWage/PWAppWageStart.asp) (<http://www.dir.ca.gov/OPRL/PWAppWage/PWAppWageStart.asp>).

^a Includes an amount for Annuity.

^b Rate applies to the first 4 overtime hours. All other time is paid at the Sunday and Holiday overtime hourly rate.

^c Saturdays in the same work week may be worked at straight-time for the first 8 hours if the job is shut down during the normal work week due to inclement weather, or reasons beyond the control of the employer.

NOT FOR BID

GENERAL PREVAILING WAGE DETERMINATION MADE BY THE DIRECTOR OF INDUSTRIAL RELATIONS
PURSUANT TO CALIFORNIA LABOR CODE PART 7, CHAPTER 1, ARTICLE 2, SECTIONS 1770, 1773 AND 1773.1
FOR COMMERCIAL BUILDING, HIGHWAY, HEAVY CONSTRUCTION AND DREDGING PROJECTS

Craft: Fire Safety and Miscellaneous Sealing

Determination:
SC-3-5-4-2021-1

Issue Date:
August 22, 2021

Expiration date of determination:
August 31, 2022* Effective until superseded by a new determination issued by the Director of Industrial Relations. Contact the Division of Labor Statistics and Research at (415) 703-4774 for the new rates after 10 days from the expiration date, if no subsequent determination is issued.

Localities:
All localities within Imperial, Inyo, Kern, Los Angeles, Mono, Orange, Riverside, San Bernardino, San Diego, San Luis Obispo, Santa Barbara, and Ventura counties.

Wages and Employer Payments:

Classification (Journey person)	Basic Hourly Rate ^d	Health and Welfare ^e	Pension	Vacation and Holiday	Other	Hours	Total Hourly Rate	Daily and Saturday Overtime Hourly Rate (1 ½ X) ^a	Sunday/ Holiday Overtime Hourly Rate (2 X)	Sunday/ Holiday Overtime Hourly Rate (3 X) ^b
Asbestos Worker, Fire Safety Technician – Class I (0-2000 hrs) ^c	\$19.60	\$10.01	\$0.00	\$0.90	\$0.05	8.0	\$30.56	\$40.36	\$50.16	\$69.76
Asbestos Worker, Fire Safety Technician – Class II (2001-4000 hrs) ^c	\$25.18	\$10.01	\$0.00	\$1.26	\$0.05	8.0	\$36.50	\$49.09	\$61.68	\$86.86
Asbestos Worker, Fire Safety Technician – Class III (4001-6000 hrs) ^c	\$27.73	\$10.01	\$8.12	\$1.33	\$0.05	8.0	\$47.24	\$61.105	\$74.97	\$102.70
Asbestos Worker, Fire Safety Technician – Class IV (6001 or more hrs) ^c	\$32.09	\$10.01	\$8.12	\$1.53	\$0.05	8.0	\$51.80	\$67.845	\$83.89	\$115.98

Wages and Employer Payments (Shift):

Classification (Journeyman) (Shift)	Basic Hourly Rate ^d	Health and Welfare ^e	Pension	Vacation and Holiday	Other	Hours	Total Hourly Rate	Daily and Saturday Overtime Hourly Rate (1 ½ X) ^f	Sunday/ Holiday Overtime Hourly Rate (2 X)	Sunday/ Holiday Overtime Hourly Rate (3 X) ^b
Asbestos Worker, Fire Safety Technician – Class I (0-2000 hrs) ^c	\$19.60	\$10.01	\$0.00	\$0.90	\$0.05	g	\$30.56	\$40.36	\$50.16	\$69.76
Asbestos Worker, Fire Safety Technician – Class II (2001-4000 hrs) ^c	\$25.18	\$10.01	\$0.00	\$1.26	\$0.05	g	\$36.50	\$49.09	\$61.68	\$86.86
Asbestos Worker, Fire Safety Technician – Class III (4001-6000 hrs) ^c	\$27.73	\$10.01	\$8.12	\$1.33	\$0.05	g	\$47.24	\$61.105	\$74.97	\$102.70
Asbestos Worker, Fire Safety Technician – Class IV (6001 or more hrs) ^c	\$32.09	\$10.01	\$8.12	\$1.53	\$0.05	g	\$51.80	\$67.845	\$83.89	\$115.98

NOT FOR BID

Determination:

SC-204-X-18-2023-1

Issue Date:

August 22, 2023

Expiration date of determination:

August 31, 2024* Effective until superseded by a new determination issued by the Director of Industrial Relations. Contact the Office of the Director – Research Unit at (415) 703-4774 for the new rates after 10 days from the expiration date, if no subsequent determination is issued.

Localities:

All localities within Imperial, Inyo, Kern, Los Angeles, Mono, Orange, Riverside, San Bernardino, San Diego, San Luis Obispo, Santa Barbara, and Ventura counties.

Wages and Employer Payments:

Classification (Journeyman)	Basic Hourly Rate ^d	Health and Welfare	Pension	Vacation and Holiday ^h	Training	Other	Hours	Total Hourly Rate	Daily and Saturday Overtime Hourly Rate (1 ½ X) ⁱ	Sunday/ Holiday Overtime Hourly Rate (2 X)	Sunday/ Holiday Overtime Hourly Rate (3 X) ^b
Plumber, Fire Safety Technician – Class I (0-2000 hrs) ^c	\$23.47	\$8.45	\$0.00	\$0.00	\$0.10	\$1.85	8.0	\$33.87	\$45.605	\$57.34	\$80.81
Plumber, Fire Safety Technician – Class II (2001-4000 hrs) ^c	\$30.05	\$8.45	\$0.00	\$0.00	\$0.10	\$1.85	8.0	\$40.45	\$55.475	\$69.815	\$98.495
Plumber, Fire Safety Technician – Class III (4001-6000 hrs) ^c	\$33.57	\$8.45	\$7.77	\$0.00	\$0.10	\$1.85	8.0	\$51.74	\$68.525	\$84.375	\$116.075
Plumber, Fire Safety Technician – Class IV (6001 or more hrs) ^c	\$38.60	\$8.45	\$7.77	\$0.00	\$0.10	\$1.85	8.0	\$56.77	\$76.07	\$93.935	\$129.665

Wages and Employer Payments (Shift):

Classification (Journeyman) (Shift)	Basic Hourly Rate ^d	Health and Welfare	Pension	Vacation and Holiday ^h	Training	Other	Hours	Total Hourly Rate	Daily and Saturday Overtime Hourly Rate (1 ½ X) ⁱ	Sunday/ Holiday Overtime Hourly Rate (2 X)	Sunday/ Holiday Overtime Hourly Rate (3 X) ^b
Plumber, Fire Safety Technician – Class I (0-2000 hrs) ^c	\$24.64	\$8.45	\$0.00	\$0.00	\$0.10	\$1.85	8.0	\$35.04	\$47.36	\$59.68	\$84.32
Plumber, Fire Safety Technician – Class II (2001-4000 hrs) ^c	\$31.48	\$8.45	\$0.00	\$0.00	\$0.10	\$1.85	8.0	\$41.88	\$57.62	\$72.675	\$102.785
Plumber, Fire Safety Technician – Class III (4001-6000 hrs) ^c	\$35.16	\$8.45	\$7.77	\$0.00	\$0.10	\$1.85	8.0	\$53.33	\$70.91	\$87.555	\$120.845
Plumber, Fire Safety Technician – Class IV (6001 or more hrs) ^c	\$40.39	\$8.45	\$7.77	\$0.00	\$0.10	\$1.85	8.0	\$58.56	\$78.755	\$97.515	\$135.035

Recognized holidays:

Holidays upon which the general prevailing hourly wage rate for Holiday work shall be paid, shall be all holidays in the collective bargaining agreement, applicable to the particular craft, classification, or type of worker employed on the project, which is on file with the Director of Industrial Relations. If the prevailing rate is not based on a collectively bargained rate, the holidays upon which the prevailing rate shall be paid shall be as provided in Section 6700 of the Government Code. You may obtain the holiday provisions for the current determinations on the [Director's General Prevailing Wage Determinations Website](http://www.dir.ca.gov/OPRL/DPreWageDetermination.htm) (<http://www.dir.ca.gov/OPRL/DPreWageDetermination.htm>). Holiday provisions for current or superseded determinations may be obtained by contacting the Office of the Director – Research Unit at (415) 703-4774.

Travel and/or subsistence payment:

In accordance with Labor Code Sections 1773.1 and 1773.9, contractors shall make travel and/or subsistence payments to each worker to execute the work. You may obtain the travel and/or subsistence provisions for the current determinations on the [Director's General Prevailing Wage Determinations Website](http://www.dir.ca.gov/OPRL/DPreWageDetermination.htm) (<http://www.dir.ca.gov/OPRL/DPreWageDetermination.htm>). Travel and/or subsistence requirements for current or superseded determinations may be obtained by contacting the Office of the Director – Research Unit at (415) 703-4774.

^a Rate applies to the first 2 daily overtime hours and the first 8 hours worked on Saturday. All other overtime is at the Sunday & Holiday rate.

^b No work shall be performed on Labor Day, except in special cases of extreme emergency and then only when triple (3) times is paid.

^c The 1st man on a job site shall be a Class IV Fire Safety Technician. A Class IV must be on a job site at all times.

^d Includes an amount per hour worked for Administrative Dues.

^e Includes an amount for Occupational Health and Research.

^f Rate applies to the first 2.5 daily overtime hours on the 2nd shift; first 3 daily overtime hours on the 3rd shift; and the first 7.5 hours (2nd shift) and first 7 hours (3rd shift) worked on Saturday. All other overtime is at the Sunday & Holiday rate.

^g When 2 or 3 shifts are employed, the 2nd shift shall work 7.5 hours for 8 hours pay; the 3rd shift shall work 7 hours for 8 hours pay.

^h Vacation/Holiday is included in the Basic Hourly Rate (no Vacation/Holiday amount for Class I Technician only) and shall be paid at time and one half for all overtime hours.

ⁱ Rate applies to the first 2 daily overtime hours and the first 10 hours worked on Saturday. All other overtime is at the Sunday & Holiday rate.

NOT FOR BID

GENERAL PREVAILING WAGE DETERMINATION MADE BY THE DIRECTOR OF INDUSTRIAL RELATIONS
PURSUANT TO CALIFORNIA LABOR CODE PART 7, CHAPTER 1, ARTICLE 2, SECTIONS 1770, 1773 AND 1773.1
FOR COMMERCIAL BUILDING, HIGHWAY, HEAVY CONSTRUCTION AND DREDGING PROJECTS

Craft: Gunite Worker (Laborer)

Determination:

SC-102-345-1-2023-1

Issue Date:

August 22, 2023

Expiration date of determination:

June 30, 2024** The rate to be paid for work performed after this date has been determined. If work will extend past this date, the new rate must be paid and should be incorporated in contracts entered into now. Contact the Office of the Director - Research Unit for specific rates at (415) 703-4774.

Localities:

All localities within Imperial, Inyo, Kern, Los Angeles, Mono, Orange, Riverside, San Bernardino, San Diego, San Luis Obispo, Santa Barbara, and Ventura counties.

Wages and Employer Payments:

Classification (Journeyman)	Basic Hourly Rate ^a	Health and Welfare	Pension	Vacation and Holiday ^b	Other	Hours	Total Hourly Rate	Daily Overtime Hourly Rate (1 ½ X) ^c	Daily Overtime Hourly Rate (2 X)	Saturday Overtime Hourly Rate (1 ½ X) ^{d e}	Saturday Overtime Hourly Rate (2 X) ^e	Sunday/ Holiday Overtime Hourly Rate (2 X)
Ground Wire Man, Nozzleman, Rodman	\$51.10	\$8.95	\$8.80	\$6.35	\$0.09	8.0	\$75.29	\$100.84	\$126.39	\$100.84	\$126.39	\$126.39
Gunman	\$50.15	\$8.95	\$8.80	\$6.35	\$0.09	8.0	\$74.34	\$99.415	\$124.49	\$99.415	\$124.49	\$124.49
Reboundman	\$46.61	\$8.95	\$8.80	\$6.35	\$0.09	8.0	\$70.80	\$94.105	\$117.41	\$94.105	\$117.41	\$117.41
Entry-Level Gunite Worker Step 1 ^f (0-1000 hours)	\$33.46	\$5.88	\$8.80	\$6.35	\$0.06	8.0	\$54.55	\$71.28	\$88.01	\$71.28	\$88.01	\$88.01
Entry-Level Gunite Worker Step 2 ^f (1001- 2000 hours)	\$35.46	\$5.88	\$8.80	\$6.35	\$0.06	8.0	\$56.55	\$74.28	\$92.01	\$74.28	\$92.01	\$92.01

Recognized holidays:

Holidays upon which the general prevailing hourly wage rate for Holiday work shall be paid, shall be all holidays in the collective bargaining agreement, applicable to the particular craft, classification, or type of worker employed on the project, which is on file with the Director of Industrial Relations. If the prevailing rate is not based on a collectively bargained rate, the holidays upon which the prevailing rate shall be paid shall be as provided in Section 6700 of the Government Code. You may obtain the holiday provisions for the current determinations on the [Director's General Prevailing Wage Determinations Website](http://www.dir.ca.gov/OPRL/DPreWageDetermination.htm) (<http://www.dir.ca.gov/OPRL/DPreWageDetermination.htm>). Holiday provisions for current or superseded determinations may be obtained by contacting the Office of the Director – Research Unit at (415) 703-4774.

Travel and/or subsistence payment:

In accordance with Labor Code Sections 1773.1 and 1773.9, contractors shall make travel and/or subsistence payments to each worker to execute the work. You may obtain the travel and/or subsistence provisions for the current determinations on the [Director's General Prevailing Wage Determinations Website](http://www.dir.ca.gov/OPRL/DPreWageDetermination.htm) (<http://www.dir.ca.gov/OPRL/DPreWageDetermination.htm>). Travel and/or subsistence requirements for current or superseded determinations may be obtained by contacting the Office of the Director – Research Unit at (415) 703-4774.

^a Employees working from a Bos'n's Chair or suspended from a rope or cable shall receive \$0.40/hour above this rate.

^b Includes an amount per hour worked for Supplemental Dues.

^c Rate applies to the first 3 overtime hours.

^d Rate applies to the first 11 overtime hours.

^e In the event it is not reasonably possible to complete forty (40) hours of work on an eight (8) hour day shift, Monday through Friday, then the balance of the forty (40) hours may be worked on Saturday at the straight time rate.

^f Ratio is one Entry-Level Gunitite Worker for the 1st 4 Journeymen on the job (although the Entry-Level Gunitite Worker may be the 2nd worker on the job) and 1 Entry-Level Gunitite Worker for every 4 Journeymen thereafter (the Entry-Level Gunitite Worker may not be on the job until after all 4 Journeymen are on the job).

NOT FOR BIDD

GENERAL PREVAILING WAGE DETERMINATION MADE BY THE DIRECTOR OF INDUSTRIAL RELATIONS
PURSUANT TO CALIFORNIA LABOR CODE PART 7, CHAPTER 1, ARTICLE 2, SECTIONS 1770, 1773 AND 1773.1
FOR COMMERCIAL BUILDING, HIGHWAY, HEAVY CONSTRUCTION AND DREDGING PROJECTS

Craft: Horizontal Directional Drilling (Laborer)#

Determination:

SC-102-1184-1-2023-1

Issue Date:

August 22, 2023

Expiration date of determination:

June 30, 2024** The rate to be paid for work performed after this date has been determined. If work will extend past this date, the new rate must be paid and should be incorporated in contracts entered into now. Contact the Office of the Director - Research Unit for specific rates at (415) 703-4774.

Localities:

All localities within Imperial, Inyo, Kern, Los Angeles, Mono, Orange, Riverside, San Bernardino, San Diego, San Luis Obispo, Santa Barbara and Ventura Counties.

Wages and Employer Payments:

Classification (Journeyman)	Basic Hourly Rate	Health and Welfare	Pension	Vacation and Holiday ^a	Training	Other	Hours	Total Hourly Rate	Daily Overtime Hourly Rate (1 ½ X)	Saturday Overtime Hourly Rate (1 ½ X) ^b	Sunday/ Holiday Overtime Hourly Rate (2 X)
Group 1 (Drilling Crew Laborer)	\$42.84	\$8.95	\$7.97	\$3.55	\$0.41	\$1.08	8	\$64.80	\$86.22	\$86.22	\$107.64
Group 2 (Vehicle Operator/ Hauler)	\$43.01	\$8.95	\$7.97	\$3.55	\$0.41	\$1.08	8	\$64.97	\$86.475	\$86.475	\$107.98
Group 3 (Horizontal Directional Drill Operator)	\$44.86	\$8.95	\$7.97	\$3.55	\$0.41	\$1.08	8	\$66.82	\$89.25	\$89.25	\$111.68
Group 4 (Electronic Tracking Locator, Subsurface Imaging Laborer)	\$46.86	\$8.95	\$7.97	\$3.55	\$0.41	\$1.08	8	\$68.82	\$92.25	\$92.25	\$115.68

Recognized holidays:

Holidays upon which the general prevailing hourly wage rate for Holiday work shall be paid, shall be all holidays in the collective bargaining agreement, applicable to the particular craft, classification, or type of worker employed on the project, which is on file with the Director of Industrial Relations. If the prevailing rate is not based on a collectively bargained rate, the holidays upon which the prevailing rate shall be paid shall be as provided in Section 6700 of the Government Code. You may obtain the holiday provisions for the current determinations on the

[Director's General Prevailing Wage Determinations Website](http://www.dir.ca.gov/OPRL/DPreWageDetermination.htm) (<http://www.dir.ca.gov/OPRL/DPreWageDetermination.htm>). Holiday provisions for current or superseded determinations may be obtained by contacting the Office of the Director – Research Unit at (415) 703-4774.

Travel and/or subsistence payment:

In accordance with Labor Code Sections 1773.1 and 1773.9, contractors shall make travel and/or subsistence payments to each worker to execute the work. You may obtain the travel and/or subsistence provisions for the current determinations on the [Director's General Prevailing Wage Determinations Website](http://www.dir.ca.gov/OPRL/DPreWageDetermination.htm) (<http://www.dir.ca.gov/OPRL/DPreWageDetermination.htm>). Travel and/or subsistence requirements for current or superseded determinations may be obtained by contacting the Office of the Director – Research Unit at (415) 703-4774.

Indicates an apprenticeable craft. The current apprentice wage rates are available on the [Prevailing Wage Apprentice Determinations Website](http://www.dir.ca.gov/OPRL/PWAppWage/PWAppWageStart.asp) (<http://www.dir.ca.gov/OPRL/PWAppWage/PWAppWageStart.asp>).

^a Includes an amount for Supplemental Dues.

^b In the event, due to inclement weather, major equipment breakdown, or similar Act of God, it is not reasonably possible to complete forty (40) hours of work Monday through Friday, then the balance of the forty (40) hours may be worked on Saturday at the straight-time rate.

NOT FOR BIDDING

GENERAL PREVAILING WAGE DETERMINATION MADE BY THE DIRECTOR OF INDUSTRIAL RELATIONS
PURSUANT TO CALIFORNIA LABOR CODE PART 7, CHAPTER 1, ARTICLE 2, SECTIONS 1770, 1773 AND 1773.1
FOR COMMERCIAL BUILDING, HIGHWAY, HEAVY CONSTRUCTION AND DREDGING PROJECTS

Craft: Housemover (Laborer)

Determination:

SC-102-507-1-2023-1

Issue Date:

August 22, 2023

Expiration date of determination:

June 30, 2024** The rate to be paid for work performed after this date has been determined. If work will extend past this date, the new rate must be paid and should be incorporated in contracts entered into now. Contact the Office of the Director - Research Unit for specific rates at (415) 703-4774.

Localities:

All localities within Imperial, Inyo, Kern, Los Angeles, Mono, Orange, Riverside, San Bernardino, San Luis Obispo, Santa Barbara and Ventura Counties.

Wages and Employer Payments:

Classification (Journey person)	Basic Hourly Rate	Health and Welfare	Pension	Vacation and Holiday ^a	Training	Other ^b	Hours	Total Hourly Rate	Daily Overtime Hourly Rate (1 ½ X) ^c	Saturday Overtime Hourly Rate (1 ½ X) ^c ^d	Sunday/ Holiday Overtime Hourly Rate (2 X)
Housemover	\$41.43	\$8.95	\$11.62	\$5.02	\$0.75	\$0.57	8.0	\$68.34	\$89.055	\$89.055	\$109.77

Recognized holidays:

Holidays upon which the general prevailing hourly wage rate for Holiday work shall be paid, shall be all holidays in the collective bargaining agreement, applicable to the particular craft, classification, or type of worker employed on the project, which is on file with the Director of Industrial Relations. If the prevailing rate is not based on a collectively bargained rate, the holidays upon which the prevailing rate shall be paid shall be as provided in Section 6700 of the Government Code. You may obtain the holiday provisions for the current determinations on the [Director's General Prevailing Wage Determinations Website](http://www.dir.ca.gov/OPRL/DPreWageDetermination.htm) (<http://www.dir.ca.gov/OPRL/DPreWageDetermination.htm>). Holiday provisions for current or superseded determinations may be obtained by contacting the Office of the Director – Research Unit at (415) 703-4774.

Travel and/or subsistence payment:

In accordance with Labor Code Sections 1773.1 and 1773.9, contractors shall make travel and/or subsistence payments to each worker to execute the work. You may obtain the travel and/or subsistence provisions for the current determinations on the [Director's General Prevailing Wage Determinations Website](http://www.dir.ca.gov/OPRL/DPreWageDetermination.htm) (<http://www.dir.ca.gov/OPRL/DPreWageDetermination.htm>). Travel and/or subsistence requirements for current or superseded determinations may be obtained by contacting the Office of the Director – Research Unit at (415) 703-4774.

^a Includes Supplemental Dues contribution.

^b Include an amount for Contract Administration Fund (\$0.07), Contract Compliance Trust Fund (\$0.30), Industry Fund (\$0.08), and Laborers Trusts' Administrative Trust Fund (\$0.06).

^c Any hours over 12 hours in a single workday are double time.

^d If the employee is unable to complete the forty (40) hours during the normal workweek, Monday through Friday, due to inclement weather or a situation beyond the employers control, then the balance of the forty (40) hours may be worked on Saturday at the straight-time rate in the same workweek.

NOT FOR BID

GENERAL PREVAILING WAGE DETERMINATION MADE BY THE DIRECTOR OF INDUSTRIAL RELATIONS
PURSUANT TO CALIFORNIA LABOR CODE PART 7, CHAPTER 1, ARTICLE 2, SECTIONS 1770, 1773 AND 1773.1
FOR COMMERCIAL BUILDING, HIGHWAY, HEAVY CONSTRUCTION AND DREDGING PROJECTS

Craft: Laborer and Related Classifications #

Determination:

SC-23-102-2-2023-1

Issue Date:

August 22, 2023

Expiration date of determination:

June 30, 2024** The rate to be paid for work performed after this date has been determined. If work will extend past this date, the new rate must be paid and should be incorporated in contracts entered into now. Contact the Office of the Director - Research Unit for specific rates at (415) 703-4774.

Localities:

All localities within Imperial, Inyo, Kern, Los Angeles, Mono, Orange, Riverside, San Bernardino, San Luis Obispo, Santa Barbara, and Ventura counties.

Wages and Employer Payments:

Classification ^a (Journeyman)	Basic Hourly Rate	Health and Welfare	Pension	Vacation and Holiday ^b	Training	Other	Hours	Total Hourly Rate	Daily Overtime Hourly Rate (1 ½ X) ^c	Saturday Overtime Hourly Rate (1 ½ X) ^{cd}	Sunday/Holiday Overtime Hourly Rate (2 X)
Group 1	\$41.38	\$8.95	\$11.62	\$5.02	\$0.75	\$0.67	8.0	\$68.39	\$89.080	\$89.080	\$109.770
Group 2	\$41.93	\$8.95	\$11.62	\$5.02	\$0.75	\$0.67	8.0	\$68.94	\$89.905	\$89.905	\$110.870
Group 3	\$42.48	\$8.95	\$11.62	\$5.02	\$0.75	\$0.67	8.0	\$69.49	\$90.730	\$90.730	\$111.970
Group 4	\$44.03	\$8.95	\$11.62	\$5.02	\$0.75	\$0.67	8.0	\$71.04	\$93.055	\$93.055	\$115.070
Group 5	\$44.38	\$8.95	\$11.62	\$5.02	\$0.75	\$0.67	8.0	\$71.39	\$93.580	\$93.580	\$115.770

Group 1

Boring Machine Helper (Outside)
Certified Confined Space Laborer
Cleaning and Handling of Panel Forms
Concrete Screeding for Rough Strike-Off
Concrete, Water Curing
Demolition Laborer, the cleaning of brick if performed by an employee performing any other phase of demolition work, and the cleaning of lumber
Fiberoptic Installation, Blowing, Splicing, and Testing Technician on public right-of-way only
Fire Watcher, Limbers, Brush Loaders, Pilers and Debris Handlers
Flagman
Gas, Oil and/or Water Pipeline Laborer
Laborer, Asphalt-Rubber Material Loader
Laborer, General or Construction
Laborer, General Cleanup
Laborer, Jetting
Laborer, Temporary Water and Air Lines
Plugging, Filling of Shee-Bolt Holes; Dry Packing of Concrete and Patching
Post Hole Digger (Manual)
Railroad Maintenance, Repair Trackman and Road Beds; Streetcar and Railroad Construction Track Laborers
Rigging and Signaling
Scaler
Slip Form Raisers
Tarman and Mortar Man
Tool Crib or Tool House Laborer
Traffic Control by any method
Water Well Driller Helper
Window Cleaner
Wire Mesh Pulling - All Concrete Pouring Operations

Group 2

Asphalt Shoveler
Cement Dumper (on 1 yard or larger mixer and handling bulk cement)
Cesspool Digger and Installer
Chucktender
Chute Man, pouring concrete, the handling of the chute from readymix trucks, such as walls, slabs, decks,

floors, foundations, footings, curbs, gutters and sidewalks
Concrete Curer-Impervious Membrane and Form Oiler
Cutting Torch Operator (Demolition)
Fine Grader, Highways and Street Paving, Airport, Runways, and similar type heavy construction
Gas, Oil and/or Water Pipeline Wrapper-Pot Tender and Form Man
Guinea Chaser
Headerboard Man-Asphalt
Installation of all Asphalt Overlay Fabric and Materials used for Reinforcing Asphalt
Laborer, Packing Rod Steel and Pans
Membrane Vapor Barrier Installer
Power Broom Sweepers (small)
Riprap, Stonepaver, placing stone or wet sacked concrete
Roto Scraper and Tiller
Sandblaster (Pot Tender)
Septic Tank Digger and Installer (leadman)
Tank Scaler and Cleaner
Tree Climber, Faller, Chain Saw Operator, Pittsburgh Chipper and similar type Brush Shredders
Underground Laborer, including Caisson Bellower

Group 3

Asphalt Installation of all fabrics
Buggymobile Man
Compactor (all types including Tampers, Barko, Wacker)
Concrete Cutting Torch
Concrete Pile Cutter
Driller, Jackhammer, 2 1/2 ft. drill steel or longer
Dri Pak-it Machine
Gas, Oil and/or Water Pipeline Wrapper - 6-inch pipe and over by any method, inside and out
Impact Wrench, Multi-Plate
Kettlemen, Potmen and Men applying asphalt, lay-kold, creosote, lime caustic and similar type materials
Laborer, Fence Erector
Material Hoseman (Walls, Slabs, Floors and Decks)
Operators of Pneumatic, Gas, Electric Tools, Vibrating Machines, Pavement Breakers, Air Blasting, Come-

Alongs, and similar mechanical tools not separately classified herein; operation of remote controlled robotic tools in connection with Laborers work
Pipelayer's backup man, coating, grouting, making of joints, sealing, caulking, diapering and including rubber gasket joints, pointing and any and all other services
Power Post Hole Digger
Rock Slinger
Rotary Scarifier or Multiple Head Concrete Chipping Scarifier
Steel Headerboard Man and Guideline Setter
Trenching Machine, Hand Propelled

Group 4

Any Worker Exposed to Raw Sewage
Asphalt Raker, Luteman, Ironer, Asphalt Dumpman, and Asphalt Spreader Boxes (all types)
Concrete Core Cutter (walls, floors or ceilings), Grinder or Sander
Concrete Saw Man, Cutting Walls or Flat Work, Scoring old or new concrete
Cribber, Shorer, Lagging, Sheeting and Trench Bracing, Hand-Guided Lagging Hammer
Head Rock Slinger
High Scaler (including drilling of same)
Laborer, Asphalt-Rubber Distributor Bootman
Laser Beam in connection with Laborer's work
Oversize Concrete Vibrator Operator, 70 pounds and over
Pipelayer
Prefabricated Manhole Installer
Sandblaster (Nozzlemann), Water Blasting, Porta Shot-Blast
Subsurface Imaging Laborer
Traffic Lane Closure, certified

Group 5

Blasters Powderman
Driller
Toxic Waste Removal
Welding, certified or otherwise in connection with Laborers' work

Recognized holidays:

Holidays upon which the general prevailing hourly wage rate for Holiday work shall be paid, shall be all holidays in the collective bargaining agreement, applicable to the particular craft, classification, or type of worker employed on the project, which is on file with the Director of Industrial Relations. If the prevailing rate is not based on a collectively bargained rate, the holidays upon which the prevailing rate shall be paid shall be as provided in Section 6700 of the Government Code. You may obtain the holiday provisions for the current determinations on the [Director's General Prevailing Wage Determinations Website](http://www.dir.ca.gov/OPRL/DPreWageDetermination.htm) (<http://www.dir.ca.gov/OPRL/DPreWageDetermination.htm>). Holiday provisions for current or superseded determinations may be obtained by contacting the Office of the Director – Research Unit at (415) 703-4774.

Travel and/or subsistence payment:

In accordance with Labor Code Sections 1773.1 and 1773.9, contractors shall make travel and/or subsistence payments to each worker to execute the work. You may obtain the travel and/or subsistence provisions for the current determinations on the [Director's General Prevailing Wage Determinations Website](http://www.dir.ca.gov/OPRL/DPreWageDetermination.htm) (<http://www.dir.ca.gov/OPRL/DPreWageDetermination.htm>). Travel and/or subsistence requirements for current or superseded determinations may be obtained by contacting the Office of the Director – Research Unit at (415) 703-4774.

Indicates an apprenticeable craft. The current apprentice wage rates are available on the [Prevailing Wage Apprentice Determinations Website](http://www.dir.ca.gov/OPRL/PWAppWage/PWAppWageStart.asp) (<http://www.dir.ca.gov/OPRL/PWAppWage/PWAppWageStart.asp>).

^a For classification within each group, see next page.

^b Includes an amount per hour worked for supplemental dues.

^c Any hours worked over 12 hours in a single workday are double (2) time.

^d Saturdays in the same work week may be worked at straight-time if job is shut down during work week due to inclement weather or similar Act of God, or a situation beyond the employer's control.

GENERAL PREVAILING WAGE DETERMINATION MADE BY THE DIRECTOR OF INDUSTRIAL RELATIONS
PURSUANT TO CALIFORNIA LABOR CODE PART 7, CHAPTER 1, ARTICLE 2, SECTIONS 1770, 1773 AND 1773.1
FOR COMMERCIAL BUILDING, HIGHWAY, HEAVY CONSTRUCTION AND DREDGING PROJECTS

Craft: Landfill Worker (Operating Engineer)

Determination:

SC-63-12-41-2023-2

Issue Date:

August 22, 2023

Expiration date of determination:

June 30, 2024** The rate to be paid for work performed after this date has been determined. If work will extend past this date, the new rate must be paid and should be incorporated in contracts entered into now. Contact the Office of the Director - Research Unit for specific rates at (415) 703-4774.

Localities:

All localities within Imperial, Inyo, Kern, Los Angeles, Mono, Orange, Riverside, San Bernardino, San Diego, San Luis Obispo, Santa Barbara, and Ventura Counties.

Wages and Employer Payments:

Classification (Journeyman)	Basic Hourly Rate	Health and Welfare ^a	Pension	Vacation and Holiday ^b	Hours	Total Hourly Rate ^c	Daily/Holiday Overtime Hourly Rate (1 ½ X) ^d	Sunday Overtime Hourly Rate (2 X)
Heavy Duty Repairman and/or Welder	\$37.05	\$6.25	\$9.65	\$0.71 ^e	8.0	\$53.66	\$65.225	\$83.750
Equipment Operator II	\$29.75	\$6.11	\$9.65	\$0.57 ^f	8.0	\$46.08	\$54.275	\$69.150
Equipment Operator III	\$30.75	\$6.13	\$9.65	\$0.59 ^g	8.0	\$47.12	\$55.775	\$71.150
PM Tech	\$26.40	\$6.05	\$9.65	\$0.51 ^h	8.0	\$42.61	\$49.250	\$62.450
Laborer/Spotter	\$19.60	\$5.92	\$4.07	\$0.38 ⁱ	8.0	\$29.97	\$33.470	\$43.270

Recognized holidays:

Holidays upon which the general prevailing hourly wage rate for Holiday work shall be paid, shall be all holidays in the collective bargaining agreement, applicable to the particular craft, classification, or type of worker employed on the project, which is on file with the Director of Industrial Relations. If the prevailing rate is not based on a collectively bargained rate, the holidays upon which the prevailing rate shall be paid shall be as provided in Section 6700 of the Government Code. You may obtain the holiday provisions for the current determinations on the [Director's General Prevailing Wage Determinations Website](http://www.dir.ca.gov/OPRL/DPreWageDetermination.htm) (http://www.dir.ca.gov/OPRL/DPreWageDetermination.htm). Holiday provisions for current or superseded determinations may be obtained by contacting the Office of the Director – Research Unit at (415) 703-4774.

Travel and/or subsistence payment:

In accordance with Labor Code Sections 1773.1 and 1773.9, contractors shall make travel and/or subsistence payments to each worker to execute the work. You may obtain the travel and/or subsistence provisions for the current determinations on the [Director's General Prevailing Wage Determinations Website](http://www.dir.ca.gov/OPRL/DPreWageDetermination.htm) (<http://www.dir.ca.gov/OPRL/DPreWageDetermination.htm>). Travel and/or subsistence requirements for current or superseded determinations may be obtained by contacting the Office of the Director – Research Unit at (415) 703-4774.

^a Includes amounts for Sick Leave and Health Insurance that apply to the first 173.33 hours worked per month.

^b This amount applies to the first 173.33 hours worked per month.

^c Computation is based on the first year of employment. This rate should be increased by any applicable vacation increase as stated in the other footnotes.

^d Rate applies to all hours worked in excess of forty (40) hours in a workweek or in excess of eight (8) hours in any one day. Rate also applies to sixth consecutive day of work. For any daily hours worked in excess of twelve (12) hours, the Sunday overtime rate would apply.

^e \$1.43 after 2 years of service; \$2.14 after 5 years of service.

^f \$1.14 after 2 years of service; \$1.72 after 5 years of service.

^g \$1.18 after 2 years of service; \$1.77 after 5 years of service.

^h \$1.02 after 2 years of service; \$1.52 after 5 years of service.

ⁱ \$0.75 after 2 years of service; \$1.13 after 5 years of service.

NOT FOR BID

GENERAL PREVAILING WAGE DETERMINATION MADE BY THE DIRECTOR OF INDUSTRIAL RELATIONS
PURSUANT TO CALIFORNIA LABOR CODE PART 7, CHAPTER 1, ARTICLE 2, SECTIONS 1770, 1773, AND 1773.1
FOR COMMERCIAL BUILDING, HIGHWAY, HEAVY CONSTRUCTION AND DREDGING PROJECTS

Craft: LANDSCAPE/IRRIGATION LABORER/TENDER#

Determination:

SC-102-X-14-2024-1

Issue Date:

February 22, 2024

Expiration date of determination:

July 31, 2024** The rate to be paid for work performed after this date has been determined. If work will extend past this date, the new rate must be paid and should be incorporated in contracts entered into now. Contact the Office of the Director - Research Unit for specific rates at (415) 703-4774.

Localities:

All localities within Imperial, Inyo, Kern, Los Angeles, Mono, Orange, Riverside, San Bernardino, San Luis Obispo, Santa Barbara, and Ventura Counties.

Wages and Employer Payments:

Classification	Basic Hourly Rate	Health and Welfare	Pension	Vacation and Holiday ^a	Training	Other	Hours	Total Hourly Rate	Daily Overtime Hourly Rate ^b (1 ½ X)	Saturday Overtime Hourly Rate ^{b,c} (1 ½ X)	Sunday/Holiday Overtime Hourly Rate (2 X)
Landscape/Irrigation Laborer	\$39.57	\$8.95	\$11.62	\$5.02	\$0.75	\$0.50	8.0	\$66.41	\$86.195	\$86.195	\$105.98
Landscape Hydro Seeder	\$40.67	\$8.95	\$11.62	\$5.02	\$0.75	\$0.50	8.0	\$67.51	\$87.845	\$87.845	\$108.18

Determination:

SC-102-X-14-2024-1A

Issue Date:

February 22, 2024

Expiration date of determination:

July 31, 2024* Effective until superseded by a new determination issued by the Director of Industrial Relations. Contact the Office of the Director – Research Unit at (415) 703-4774 for new rates after 10 days from the expiration date if no subsequent determination is issued.

Localities:

All localities within Imperial, Inyo, Kern, Los Angeles, Mono, Orange, Riverside, San Bernardino, San Luis Obispo, Santa Barbara, and Ventura Counties.

Wages and Employer Payments:

Classification	Basic Hourly Rate	Health and Welfare	Pension	Vacation and Holiday ^a	Training	Other	Hours	Total Hourly Rate	Daily Overtime Hourly Rate ^b (1 ½ X)	Saturday Overtime Hourly Rate ^{b,c} (1 ½ X)	Sunday/Holiday Overtime Hourly Rate (2 X)
Landscape/Irrigation Tender ^d	\$20.80	\$3.60	\$2.19	\$1.18	\$0.00	\$0.00	8.0	\$27.77	\$38.170	\$38.170	\$48.570

Recognized holidays:

Holidays upon which the general prevailing hourly wage rate for Holiday work shall be paid, shall be all holidays in the collective bargaining agreement, applicable to the particular craft, classification, or type of worker employed on the project, which is on file with the Director of Industrial Relations. If the prevailing rate is not based on a collectively bargained rate, the holidays upon which the prevailing rate shall be paid shall be as provided in Section 6700 of the Government Code. You may obtain the holiday provisions for the current determinations on the [Director's General Prevailing Wage Determinations Website](http://www.dir.ca.gov/OPRL/DPreWageDetermination.htm) (<http://www.dir.ca.gov/OPRL/DPreWageDetermination.htm>). Holiday provisions for current or superseded determinations may be obtained by contacting the Office of the Director – Research Unit at (415) 703-4774.

Travel and/or subsistence payment:

In accordance with Labor Code Sections 1773.1 and 1773.9, contractors shall make travel and/or subsistence payments to each worker to execute the work. You may obtain the travel and/or subsistence provisions for the current determinations on the [Director's General Prevailing Wage Determinations Website](http://www.dir.ca.gov/OPRL/DPreWageDetermination.htm) (<http://www.dir.ca.gov/OPRL/DPreWageDetermination.htm>). Travel and/or subsistence requirements for current or superseded determinations may be obtained by contacting the Office of the Director – Research Unit at (415) 703-4774.

Indicates an apprenticeable craft. The current apprentice wage rates are available on the [Prevailing Wage Apprentice Determinations Website](http://www.dir.ca.gov/OPRL/PWAppWage/PWAppWageStart.asp) (<http://www.dir.ca.gov/OPRL/PWAppWage/PWAppWageStart.asp>).

^a Includes an amount per hour worked for Supplemental Dues.

^b Rate applies to first 4 daily overtime hours and the first 12 hours on Saturday. All other time is paid at the Sunday and Holiday double-time rate.

^c Saturdays in the same work week may be worked at straight-time if adverse weather or jobsite ground conditions require that the job be shut down for one or more workdays during the regular workweek.

^d The first employee on the jobsite shall be a Landscape/Irrigation Laborer; the second employee on the jobsite must be an Apprentice or a Landscape/Irrigation Laborer; and the third and fourth employees may be Tenders. The fifth employee on the jobsite shall be a Landscape/Irrigation Laborer; the sixth employee must be an Apprentice or a Landscape/Irrigation Laborer; and the seventh and eighth employees may be Tenders. Thereafter, Tenders may be employed with Landscape/Irrigation Laborers in a 50/50 ratio on each jobsite. However, plant establishment may be performed exclusively by Landscape/Irrigation Tenders without the supervision of a Journeyman.

GENERAL PREVAILING WAGE DETERMINATION MADE BY THE DIRECTOR OF INDUSTRIAL RELATIONS
PURSUANT TO CALIFORNIA LABOR CODE PART 7, CHAPTER 1, ARTICLE 2, SECTIONS 1770, 1773 AND 1773.1

Craft: Landscape Maintenance Laborer

(Applies Only to Routine Landscape Maintenance Work, Not New Landscape Construction) ^a

Determination:

SC-LML-2024-1

Issue Date:

February 22, 2024

Expiration date of determination:

March 31, 2024* Effective until superseded by a new determination issued by the Director of Industrial Relations. Contact the Office of the Director – Research Unit (415) 703-4774 for the new rates after 10 days from the expiration date, if no subsequent determination is issued.

Wages and Employer Payments:

Locality	Basic Hourly Rate	Health and Welfare	Pension	Vacation	Holiday	Training	Hours	Total Hourly Rate	Overtime Hourly Rate (1 ½ X)
Imperial	\$16.00	\$0.00	\$0.00	\$0.115 ^b	\$0.17	\$0.00	8.0	\$16.285 ^c	\$24.285 ^c
Inyo, Mono and San Bernardino	\$16.00	\$0.00	\$0.00	\$0.30	\$0.17	\$0.00	8.0	\$16.47	\$24.47
Kern	\$16.00	\$0.00	\$0.00	\$0.16 ^d	\$0.17	\$0.00	8.0	\$16.33 ^c	\$24.33 ^c
	\$16.00	\$0.00	\$0.00	\$0.27 ^e	\$0.46	\$0.00	8.0	\$16.73 ^c	\$24.73 ^c
Los Angeles	\$16.00	\$0.89	\$0.00	\$0.115 ^f	\$0.14	\$0.00	8.0	\$17.145 ^c	\$25.145 ^c
Orange	\$16.00	\$0.00	\$0.00	\$0.11 ^g	\$0.11	\$0.00	8.0	\$16.22 ^c	\$24.22 ^c
Riverside	\$16.00	\$0.00	\$0.00	\$0.20 ^h	\$0.16	\$0.00	8.0	\$16.36 ^c	\$24.36 ^c
San Diego	\$16.00	\$0.00	\$0.00	\$0.22	\$0.115	\$0.00	8.0	\$16.335	\$24.335
	\$16.00	\$0.00	\$0.00	\$0.24	\$0.12	\$0.00	8.0	\$16.36	\$24.36
San Luis Obispo	\$16.00	\$0.00	\$0.00	\$0.15 ⁱ	\$0.15	\$0.00	8.0	\$16.30	\$24.30
	\$16.00	\$0.00	\$0.00	\$0.16 ^j	\$0.16	\$0.00	8.0	\$16.32	\$24.32
Santa Barbara	\$16.00	\$0.00	\$0.00	\$0.12 ^k	\$0.12	\$0.00	8.0	\$16.24 ^c	\$24.24 ^c
	\$16.00	\$0.00	\$0.00	\$0.13 ^l	\$0.13	\$0.00	8.0	\$16.26 ^c	\$24.26 ^c
Ventura	\$16.00	\$0.00	\$0.00	\$0.115	\$0.16	\$0.00	8.0	\$16.275	\$24.275
	\$16.00	\$2.97	\$0.00	\$0.19 ^m	\$0.26	\$0.00	8.0	\$19.42 ^c	\$27.42 ^c

NOTE:

If there are two rates, the first rate is for routine work, the second rate is for complex work.

Recognized holidays:

Holidays upon which the general prevailing hourly wage rate for Holiday work shall be paid, shall be all holidays in the collective bargaining agreement, applicable to the particular craft, classification, or type of worker employed on the project, which is on file with the Director of Industrial Relations. If the prevailing rate is not based on a collectively bargained rate, the holidays upon which the prevailing rate shall be paid shall be as provided in Section 6700 of the Government Code. You may obtain the holiday provisions for the current determinations on the [Director's General Prevailing Wage Determinations Website](http://www.dir.ca.gov/OPRL/DPreWageDetermination.htm) (<http://www.dir.ca.gov/OPRL/DPreWageDetermination.htm>). Holiday provisions for current or superseded determinations may be obtained by contacting the Office of the Director – Research Unit at (415) 703-4774.

Travel and/or subsistence payment:

In accordance with Labor Code Sections 1773.1 and 1773.9, contractors shall make travel and/or subsistence payments to each worker to execute the work. You may obtain the travel and/or subsistence provisions for the current determinations on the [Director's General Prevailing Wage Determinations Website](http://www.dir.ca.gov/OPRL/DPreWageDetermination.htm) (<http://www.dir.ca.gov/OPRL/DPreWageDetermination.htm>). Travel and/or subsistence requirements for current or superseded determinations may be obtained by contacting the Office of the Director – Research Unit at (415) 703-4774.

^a This determination does not apply to work of a landscape laborer employed on landscape construction (work incidental to construction or post-construction maintenance during the plant installation and establishment period). The following is a description of the landscape work cover under this determination:

ROUTINE – mowing, watering, pruning, trimming, weeding, spraying, occasional planting and replacement of plants and janitorial work incidental to such landscape maintenance.

COMPLEX – servicing of irrigation and sprinkler systems, repairing of equipment use in such landscape maintenance.

^b \$0.22 after 3 years of service.

^c Computation is based on the first years of employment. This rate should be increased by any applicable vacation increase as stated in other footnotes.

^d \$0.31 after 2 years of service.

^e \$0.54 after 2 years of service: \$0.81 after 3 years of service.

^f \$0.24 after 3 years of service: \$0.37 after 7 years of service.

^g \$0.22 after 4 years of service.

^h \$0.40 after 3 years of service.

ⁱ \$0.29 after 2 years of service.

^j \$0.31 after 2 years of service.

^k \$0.23 after 2 years of service.

^l \$0.27 after 2 years of service.

^m \$0.38 after 3 years of service.

GENERAL PREVAILING WAGE DETERMINATION MADE BY THE DIRECTOR OF INDUSTRIAL RELATIONS
PURSUANT TO CALIFORNIA LABOR CODE PART 7, CHAPTER 1, ARTICLE 2, SECTIONS 1770, 1773 AND 1773.1
FOR COMMERCIAL BUILDING, HIGHWAY, HEAVY CONSTRUCTION AND DREDGING PROJECTS

Craft: Landscape Operating Engineer[#]

Determination:

SC-63-12-33-2024-1

Issue Date:

February 22, 2024

Expiration date of determination:

October 31, 2024** The rate to be paid for work performed after this date has been determined. If work will extend past this date, the new rate must be paid and should be incorporated in contracts entered into now. Contact the Office of the Director - Research Unit for specific rates at (415) 703-4774.

Localities:

All localities within Imperial, Inyo, Kern, Los Angeles, Mono, Orange, Riverside, San Bernardino, San Diego, San Luis Obispo, Santa Barbara, and Ventura Counties.

Wages and Employer Payments:

Classification (Journeyman)	Basic Hourly Rate	Health and Welfare	Pension ^a	Vacation and Holiday ^b	Training	Other	Hours	Total Hourly Rate	Daily/ Saturday Overtime Hourly Rate ^c (1½ X)	Sunday Overtime Hourly Rate ^d (2X)	Holiday Overtime Hourly Rate ^d (3X)
Landscape Operating Engineer: Backhoe Operators; Skidsteer; Forklifts-Tree Planting Equipment (jobsite); HDR Welder-Landscape, Irrigation, Operating Engineers' Equipment; Mulching Tractors; Roller Operators; Rubber-tired & Track Earthmoving Equipment; Skiploader Operators; Trencher-31 horsepower and up	\$48.01	\$12.85	\$13.15	\$3.85	\$1.05	\$0.15	8.0	\$80.56	\$104.565	\$128.570	\$176.58

Recognized holidays:

Holidays upon which the general prevailing hourly wage rate for Holiday work shall be paid, shall be all holidays in the collective bargaining agreement, applicable to the particular craft, classification, or type of worker employed on the project, which is on file with the Director of Industrial Relations. If the prevailing rate is not based on a collectively bargained rate, the holidays upon which the prevailing rate shall be paid shall be as provided in Section 6700 of the Government Code. You may obtain the holiday provisions for the current determinations on the [Director's General Prevailing Wage Determinations Website](http://www.dir.ca.gov/OPRL/DPreWageDetermination.htm) (<http://www.dir.ca.gov/OPRL/DPreWageDetermination.htm>). Holiday provisions for current or superseded determinations may be obtained by contacting the Office of the Director – Research Unit at (415) 703-4774.

Travel and/or subsistence payment:

In accordance with Labor Code Sections 1773.1 and 1773.9, contractors shall make travel and/or subsistence payments to each worker to execute the work. You may obtain the travel and/or subsistence provisions for the current determinations on the [Director's General Prevailing Wage Determinations Website](http://www.dir.ca.gov/OPRL/DPreWageDetermination.htm) (<http://www.dir.ca.gov/OPRL/DPreWageDetermination.htm>). Travel and/or subsistence requirements for current or superseded determinations may be obtained by contacting the Office of the Director – Research Unit at (415) 703-4774.

Indicates an apprenticeable craft. The current apprentice wage rates are available on the [Prevailing Wage Apprentice Determinations Website](http://www.dir.ca.gov/OPRL/PWAppWage/PWAppWageStart.asp) (<http://www.dir.ca.gov/OPRL/PWAppWage/PWAppWageStart.asp>).

^a Includes an amount for the Defined Contribution Plan (Annuity).

^b Includes an amount per hour worked for supplemental dues.

^c Rate applies to the first four overtime hours daily and the first twelve hours on Saturday. Thereafter use the Sunday overtime rate.

^d All work performed on a Dewatering Operation on holidays and all other work on holidays except Labor Day and the 1st Saturday following the 1st Friday in the months of June and December is paid at Sunday rate.

NOT FOR BIDDING

GENERAL PREVAILING WAGE DETERMINATION MADE BY THE DIRECTOR OF INDUSTRIAL RELATIONS
PURSUANT TO CALIFORNIA LABOR CODE PART 7, CHAPTER 1, ARTICLE 2, SECTIONS 1770, 1773 AND 1773.1
FOR COMMERCIAL BUILDING, HIGHWAY, HEAVY CONSTRUCTION AND DREDGING PROJECTS

Craft: Light Fixture Maintenance

Determination:

SC-830-61-1-2024-1

Issue Date:

February 22, 2024

Expiration date of determination:

March 31, 2024* Effective until superseded by a new determination issued by the Director of Industrial Relations. Contact the Office of the Director – Research Unit at (415) 703-4774 for the new rates after 10 days from the expiration date, if no subsequent determination is issued.

Localities:

All localities within **Riverside** County. For other counties please contact the Office of the Director – Research Unit prior to Bid Advertisement at (415) 703-4774.

Wages and Employer Payments:

Classification (Journeyman)	Basic Hourly Rate	Health and Welfare	Pension	Vacation and Holiday	Training	Hours	Total Hourly Rate	Daily Overtime Hourly Rate (1½ X)	Saturday/Sunday Overtime Hourly Rate (1½ X)	Holiday Overtime Hourly Rate (2 X)
Lighting Maintenance Service Person	\$16.00	\$0.29	\$0.00	\$0.34	\$0.00	8.0	\$16.63	\$24.63	\$24.63	\$32.63

Determination:

SC-830-61-2-2024-1

Issue Date:

February 22, 2024

Expiration date of determination:

March 31, 2024* Effective until superseded by a new determination issued by the Director of Industrial Relations. Contact the Office of the Director – Research Unit at (415) 703-4774 for the new rates after 10 days from the expiration date, if no subsequent determination is issued.

Localities:

All localities within **San Bernardino** County. For other counties please contact the Office of the Director – Research Unit prior to Bid Advertisement at (415) 703-4774.

Wages and Employer Payments:

Classification	Basic Hourly Rate	Health and Welfare	Pension	Vacation and Holiday	Training	Hours	Total Hourly Rate	Daily Overtime Hourly Rate (1 ½ X)	Sunday/ Holiday Overtime Hourly Rate (1 ½ X)
Lighting Maintenance Service Person	\$16.00	\$2.43	\$0.39	\$0.00	\$0.50	8.0	\$19.32	\$27.32	\$27.32

Recognized holidays:

Holidays upon which the general prevailing hourly wage rate for Holiday work shall be paid, shall be all holidays in the collective bargaining agreement, applicable to the particular craft, classification, or type of worker employed on the project, which is on file with the Director of Industrial Relations. If the prevailing rate is not based on a collectively bargained rate, the holidays upon which the prevailing rate shall be paid shall be as provided in Section 6700 of the Government Code. You may obtain the holiday provisions for the current determinations on the [Director's General Prevailing Wage Determinations Website](http://www.dir.ca.gov/OPRL/DPreWageDetermination.htm) (http://www.dir.ca.gov/OPRL/DPreWageDetermination.htm). Holiday provisions for current or superseded determinations may be obtained by contacting the Office of the Director – Research Unit at (415) 703-4774.

Travel and/or subsistence payment:

In accordance with Labor Code Sections 1773.1 and 1773.9, contractors shall make travel and/or subsistence payments to each worker to execute the work. You may obtain the travel and/or subsistence provisions for the current determinations on the [Director's General Prevailing Wage Determinations Website](http://www.dir.ca.gov/OPRL/DPreWageDetermination.htm) (http://www.dir.ca.gov/OPRL/DPreWageDetermination.htm). Travel and/or subsistence requirements for current or superseded determinations may be obtained by contacting the Office of the Director – Research Unit at (415) 703-4774.

GENERAL PREVAILING WAGE DETERMINATION MADE BY THE DIRECTOR OF INDUSTRIAL RELATIONS
PURSUANT TO CALIFORNIA LABOR CODE PART 7, CHAPTER 1, ARTICLE 2, SECTIONS 1770, 1773 AND 1773.1
FOR COMMERCIAL BUILDING, HIGHWAY, HEAVY CONSTRUCTION AND DREDGING PROJECTS

Craft: Modular Furniture Installer (Carpenter)#

Determination:

SC-23-31-16-2024-1

Issue Date:

February 22, 2024

Expiration date of determination:

June 30, 2024** The rate to be paid for work performed after this date has been determined. If work will extend past this date, the new rate must be paid and should be incorporated in contracts entered into now. Contact the Office of the Director - Research Unit for specific rates at (415) 703-4774.

Localities:

All localities within Imperial, Inyo, Kern, Los Angeles, Mono, Orange, Riverside, San Bernardino, San Diego, San Luis Obispo, Santa Barbara, and Ventura Counties

Wages and Employer Payments:

Classification (Journeyman)	Basic Hourly Rate	Health and Welfare	Pension	Vacation and Holiday ^a	Training	Other	Hours	Total Hourly Rate	Daily Overtime Hourly Rate ^b (1 ½ X)	6 th Workday Overtime Hourly Rate ^b (1 ½ X)	7 th Workday/ Holiday Overtime Hourly Rate (2 X)
Modular Installer: Installer	\$22.00	\$6.21	\$2.50	\$3.10	\$0.10	\$0.03	8.0	\$33.94	\$44.94	\$44.94	\$55.94
Modular Installer: Lead Installer	\$24.00	\$6.21	\$2.50	\$3.10	\$0.10	\$0.03	8.0	\$35.94	\$47.94	\$47.94	\$59.94

Recognized holidays:

Holidays upon which the general prevailing hourly wage rate for Holiday work shall be paid, shall be all holidays in the collective bargaining agreement, applicable to the particular craft, classification, or type of worker employed on the project, which is on file with the Director of Industrial Relations. If the prevailing rate is not based on a collectively bargained rate, the holidays upon which the prevailing rate shall be paid shall be as provided in Section 6700 of the Government Code. You may obtain the holiday provisions for the current determinations on the [Director's General Prevailing Wage Determinations Website](http://www.dir.ca.gov/OPRL/DPreWageDetermination.htm) (http://www.dir.ca.gov/OPRL/DPreWageDetermination.htm). Holiday provisions for current or superseded determinations may be obtained by contacting the Office of the Director – Research Unit at (415) 703-4774.

Travel and/or subsistence payment:

In accordance with Labor Code Sections 1773.1 and 1773.9, contractors shall make travel and/or subsistence payments to each worker to execute the work. You may obtain the travel and/or subsistence provisions for the current determinations on the [Director's General Prevailing Wage Determinations Website](http://www.dir.ca.gov/OPRL/DPreWageDetermination.htm) (<http://www.dir.ca.gov/OPRL/DPreWageDetermination.htm>). Travel and/or subsistence requirements for current or superseded determinations may be obtained by contacting the Office of the Director – Research Unit at (415) 703-4774.

Indicates an apprenticeable craft. The current apprentice wage rates are available on the [Prevailing Wage Apprentice Determinations Website](http://www.dir.ca.gov/OPRL/PWAppWage/PWAppWageStart.asp) (<http://www.dir.ca.gov/OPRL/PWAppWage/PWAppWageStart.asp>).

^a Includes an amount for Supplemental Dues.

^b Rate applies to the first 4 daily overtime hours and first 12 hours worked on a sixth (6th) consecutive day. All other daily overtime is paid the 7th Workday/Holiday rate.

NOT FOR BID

GENERAL PREVAILING WAGE DETERMINATION MADE BY
 THE DIRECTOR OF INDUSTRIAL RELATIONS PURSUANT TO CALIFORNIA LABOR CODE
 PART 7, CHAPTER 1, ARTICLE 2, SECTIONS 1770, 1773 AND 1773.1
 FOR COMMERCIAL BUILDING, HIGHWAY, HEAVY CONSTRUCTION AND DREDGING PROJECTS

CRAFT: OPERATING ENGINEER#

Determination:

SC-23-63-2-2023-2

Issue Date:

August 22, 2023

Expiration date of determination:

June 30, 2024** The rate to be paid for work performed after this date has been determined. If work will extend past this date, the new rate must be paid and should be incorporated in contracts entered into now. Contact the Office of the Director - Research Unit for specific rates at (415) 703-4774.

Localities:

All localities within Imperial, Inyo, Kern, Los Angeles, Mono, Orange, Riverside, San Bernardino, San Luis Obispo, Santa Barbara and Ventura Counties.

Wages and total hourly rates (including employer payments):

Classification ^a (Journeyman)	Basic Hourly Rate	Hours	Total Hourly Rate	Daily Overtime Hourly Rate ^b (1½ x)	Saturday Overtime Hourly Rate ^c (1½ x)	Sunday/Holiday Overtime Hourly Rate (2 x)
Group 1	\$55.90	8	\$88.71	\$116.660	\$116.660	\$144.610
Group 2	\$56.68	8	\$89.49	\$117.830	\$117.830	\$146.170
Group 3	\$56.97	8	\$89.78	\$118.265	\$118.265	\$146.750
Group 4	\$58.46	8	\$91.27	\$120.500	\$120.500	\$149.730
Group 6	\$58.68	8	\$91.49	\$120.830	\$120.830	\$150.170
Group 8	\$58.79	8	\$91.60	\$120.995	\$120.995	\$150.390
Group 10	\$58.91	8	\$91.72	\$121.175	\$121.175	\$150.630
Group 12	\$59.08	8	\$91.89	\$121.430	\$121.430	\$150.970
Group 13	\$59.18	8	\$91.99	\$121.580	\$121.580	\$151.170
Group 14	\$59.21	8	\$92.02	\$121.625	\$121.625	\$151.230
Group 15	\$59.29	8	\$92.10	\$121.745	\$121.745	\$151.390
Group 16	\$59.41	8	\$92.22	\$121.925	\$121.925	\$151.630
Group 17	\$59.58	8	\$92.39	\$122.180	\$122.180	\$151.970
Group 18	\$59.68	8	\$92.49	\$122.330	\$122.330	\$152.170
Group 19	\$59.79	8	\$92.60	\$122.495	\$122.495	\$152.390
Group 20	\$59.91	8	\$92.72	\$122.675	\$122.675	\$152.630
Group 21	\$60.08	8	\$92.89	\$122.930	\$122.930	\$152.970
Group 22	\$60.18	8	\$92.99	\$123.080	\$123.080	\$153.170
Group 23	\$60.29	8	\$93.10	\$123.245	\$123.245	\$153.390
Group 24	\$60.41	8	\$93.22	\$123.425	\$123.425	\$153.630
Group 25	\$60.58	8	\$93.39	\$123.680	\$123.680	\$153.970

Employer Payments:

Type of Fund	Amount per Hour
Health and Welfare	\$12.85
Pension ^d	\$14.65
Vacation and Holiday ^e	\$3.85
Training	\$1.05
Other	\$0.41

Recognized holidays:

Holidays upon which the general prevailing hourly wage rate for Holiday work shall be paid, shall be all holidays in the collective bargaining agreement, applicable to the particular craft, classification, or type of worker employed on the project, which is on file with the Director of Industrial Relations. If the prevailing rate is not based on a collectively bargained rate, the holidays upon which the prevailing rate shall be paid shall be as provided in Section 6700 of the Government Code. You may obtain the holiday provisions for the current determinations on the [Director's General Prevailing Wage Determinations Website](http://www.dir.ca.gov/OPRL/DPreWageDetermination.htm) (<http://www.dir.ca.gov/OPRL/DPreWageDetermination.htm>). Holiday provisions for current or superseded determinations may be obtained by contacting the Office of the Director – Research Unit at (415) 703-4774.

Travel and/or subsistence payment:

In accordance with Labor Code Sections 1773.1 and 1773.9, contractors shall make travel and/or subsistence payments to each worker to execute the work. You may obtain the travel and/or subsistence provisions for the current determinations on the [Director's General Prevailing Wage Determinations Website](http://www.dir.ca.gov/OPRL/DPreWageDetermination.htm) (<http://www.dir.ca.gov/OPRL/DPreWageDetermination.htm>). Travel and/or subsistence requirements for current or superseded determinations may be obtained by contacting the Office of the Director – Research Unit at (415) 703-4774.

NOT FOR BIDDING

GENERAL PREVAILING WAGE DETERMINATION MADE BY
THE DIRECTOR OF INDUSTRIAL RELATIONS PURSUANT TO CALIFORNIA LABOR CODE
PART 7, CHAPTER 1, ARTICLE 2, SECTIONS 1770, 1773 AND 1773.1
FOR COMMERCIAL BUILDING, HIGHWAY, HEAVY CONSTRUCTION AND DREDGING PROJECTS

CRAFT: OPERATING ENGINEER (SPECIAL SHIFT) #

Determination:

SC-23-63-2-2023-2

Issue Date:

August 22, 2023

Expiration date of determination:

June 30, 2024** The rate to be paid for work performed after this date has been determined. If work will extend past this date, the new rate must be paid and should be incorporated in contracts entered into now. Contact the Office of the Director - Research Unit for specific rates at (415) 703-4774.

Localities:

All localities within Imperial, Inyo, Kern, Los Angeles, Mono, Orange, Riverside, San Bernardino, San Luis Obispo, Santa Barbara and Ventura Counties.

Wages and total hourly rates (including employer payments):

Classification ^a (Journeyman)	Basic Hourly Rate	Hours	Total Hourly Rate	Daily Overtime Hourly Rate ^b (1½ x)	Saturday Overtime Hourly Rate ^c (1½ x)	Sunday/Holiday Overtime Hourly Rate (2 x)
Group 1	\$56.90	8	\$89.71	\$118.160	\$118.160	\$146.610
Group 2	\$57.68	8	\$90.49	\$119.330	\$119.330	\$148.170
Group 3	\$57.97	8	\$90.78	\$119.765	\$119.765	\$148.750
Group 4	\$59.46	8	\$92.27	\$122.000	\$122.000	\$151.730
Group 6	\$59.68	8	\$92.49	\$122.330	\$122.330	\$152.170
Group 8	\$59.79	8	\$92.60	\$122.495	\$122.495	\$152.390
Group 10	\$59.91	8	\$92.72	\$122.675	\$122.675	\$152.630
Group 12	\$60.08	8	\$92.89	\$122.930	\$122.930	\$152.970
Group 13	\$60.18	8	\$92.99	\$123.080	\$123.080	\$153.170
Group 14	\$60.21	8	\$93.02	\$123.125	\$123.125	\$153.230
Group 15	\$60.29	8	\$93.10	\$123.245	\$123.245	\$153.390
Group 16	\$60.41	8	\$93.22	\$123.425	\$123.425	\$153.630
Group 17	\$60.58	8	\$93.39	\$123.680	\$123.680	\$153.970
Group 18	\$60.68	8	\$93.49	\$123.830	\$123.830	\$154.170
Group 19	\$60.79	8	\$93.60	\$123.995	\$123.995	\$154.390
Group 20	\$60.91	8	\$93.72	\$124.175	\$124.175	\$154.630
Group 21	\$61.08	8	\$93.89	\$124.430	\$124.430	\$154.970
Group 22	\$61.18	8	\$93.99	\$124.580	\$124.580	\$155.170
Group 23	\$61.29	8	\$94.10	\$124.745	\$124.745	\$155.390
Group 24	\$61.41	8	\$94.22	\$124.925	\$124.925	\$155.630
Group 25	\$61.58	8	\$94.39	\$125.180	\$125.180	\$155.970

Employer Payments:

Type of Fund	Amount per Hour
Health and Welfare	\$12.85
Pension ^d	\$14.65
Vacation and Holiday ^e	\$3.85
Training	\$1.05
Other	\$0.41

Recognized holidays:

Holidays upon which the general prevailing hourly wage rate for Holiday work shall be paid, shall be all holidays in the collective bargaining agreement, applicable to the particular craft, classification, or type of worker employed on the project, which is on file with the Director of Industrial Relations. If the prevailing rate is not based on a collectively bargained rate, the holidays upon which the prevailing rate shall be paid shall be as provided in Section 6700 of the Government Code. You may obtain the holiday provisions for the current determinations on the [Director's General Prevailing Wage Determinations Website](http://www.dir.ca.gov/OPRL/DPreWageDetermination.htm) (<http://www.dir.ca.gov/OPRL/DPreWageDetermination.htm>). Holiday provisions for current or superseded determinations may be obtained by contacting the Office of the Director – Research Unit at (415) 703-4774.

Travel and/or subsistence payment:

In accordance with Labor Code Sections 1773.1 and 1773.9, contractors shall make travel and/or subsistence payments to each worker to execute the work. You may obtain the travel and/or subsistence provisions for the current determinations on the [Director's General Prevailing Wage Determinations Website](http://www.dir.ca.gov/OPRL/DPreWageDetermination.htm) (<http://www.dir.ca.gov/OPRL/DPreWageDetermination.htm>). Travel and/or subsistence requirements for current or superseded determinations may be obtained by contacting the Office of the Director – Research Unit at (415) 703-4774.

NOT FOR BIDDING

GENERAL PREVAILING WAGE DETERMINATION MADE BY
THE DIRECTOR OF INDUSTRIAL RELATIONS PURSUANT TO CALIFORNIA LABOR CODE
PART 7, CHAPTER 1, ARTICLE 2, SECTIONS 1770, 1773 AND 1773.1
FOR COMMERCIAL BUILDING, HIGHWAY, HEAVY CONSTRUCTION AND DREDGING PROJECTS

CRAFT: OPERATING ENGINEER (MULTI-SHIFT)#

Determination:

SC-23-63-2-2023-2

Issue Date:

August 22, 2023

Expiration date of determination:

June 30, 2024** The rate to be paid for work performed after this date has been determined. If work will extend past this date, the new rate must be paid and should be incorporated in contracts entered into now. Contact the Office of the Director - Research Unit for specific rates at (415) 703-4774.

Localities:

All localities within Imperial, Inyo, Kern, Los Angeles, Mono, Orange, Riverside, San Bernardino, San Luis Obispo, Santa Barbara and Ventura Counties.

Wages and total hourly rates (including employer payments):

Classification ^a (Journeyman)	Basic Hourly Rate	Hours ^f	Total Hourly Rate	Daily Overtime Hourly Rate ^b (1½ x)	Saturday Overtime Hourly Rate ^c (1½ x)	Sunday/Holiday Overtime Hourly Rate (2 x)
Group 1	\$56.90	8	\$89.71	\$118.160	\$118.160	\$146.610
Group 2	\$57.68	8	\$90.49	\$119.330	\$119.330	\$148.170
Group 3	\$57.97	8	\$90.78	\$119.765	\$119.765	\$148.750
Group 4	\$59.46	8	\$92.27	\$122.000	\$122.000	\$151.730
Group 5	\$59.56	8	\$92.37	\$122.150	\$122.150	\$151.930
Group 6	\$59.68	8	\$92.49	\$122.330	\$122.330	\$152.170
Group 7	\$59.78	8	\$92.59	\$122.480	\$122.480	\$152.370
Group 8	\$59.79	8	\$92.60	\$122.495	\$122.495	\$152.390
Group 9	\$59.89	8	\$92.70	\$122.645	\$122.645	\$152.590
Group 10	\$59.91	8	\$92.72	\$122.675	\$122.675	\$152.630
Group 11	\$60.01	8	\$92.82	\$122.825	\$122.825	\$152.830
Group 12	\$60.08	8	\$92.89	\$122.930	\$122.930	\$152.970
Group 13	\$60.18	8	\$92.99	\$123.080	\$123.080	\$153.170
Group 14	\$60.21	8	\$93.02	\$123.125	\$123.125	\$153.230
Group 15	\$60.29	8	\$93.10	\$123.245	\$123.245	\$153.390
Group 16	\$60.41	8	\$93.22	\$123.425	\$123.425	\$153.630
Group 17	\$60.58	8	\$93.39	\$123.680	\$123.680	\$153.970
Group 18	\$60.68	8	\$93.49	\$123.830	\$123.830	\$154.170
Group 19	\$60.79	8	\$93.60	\$123.995	\$123.995	\$154.390
Group 20	\$60.91	8	\$93.72	\$124.175	\$124.175	\$154.630
Group 21	\$61.08	8	\$93.89	\$124.430	\$124.430	\$154.970
Group 22	\$61.18	8	\$93.99	\$124.580	\$124.580	\$155.170
Group 23	\$61.29	8	\$94.10	\$124.745	\$124.745	\$155.390
Group 24	\$61.41	8	\$94.22	\$124.925	\$124.925	\$155.630

Classification ^a (Journey person)	Basic Hourly Rate	Hours ^f	Total Hourly Rate	Daily Overtime Hourly Rate ^b (1½ x)	Saturday Overtime Hourly Rate ^c (1½ x)	Sunday/Holiday Overtime Hourly Rate (2 x)
Group 25	\$61.58	8	\$94.39	\$125.180	\$125.180	\$155.970

Employer Payments:

Type of Fund	Amount per Hour
Health and Welfare	\$12.85
Pension ^d	\$14.65
Vacation and Holiday ^e	\$3.85
Training	\$1.05
Other	\$0.41

Recognized holidays:

Holidays upon which the general prevailing hourly wage rate for Holiday work shall be paid, shall be all holidays in the collective bargaining agreement, applicable to the particular craft, classification, or type of worker employed on the project, which is on file with the Director of Industrial Relations. If the prevailing rate is not based on a collectively bargained rate, the holidays upon which the prevailing rate shall be paid shall be as provided in Section 6700 of the Government Code. You may obtain the holiday provisions for the current determinations on the [Director's General Prevailing Wage Determinations Website](http://www.dir.ca.gov/OPRL/DPreWageDetermination.htm) (<http://www.dir.ca.gov/OPRL/DPreWageDetermination.htm>). Holiday provisions for current or superseded determinations may be obtained by contacting the Office of the Director – Research Unit at (415) 703-4774.

Travel and/or subsistence payment:

In accordance with Labor Code Sections 1773.1 and 1773.9, contractors shall make travel and/or subsistence payments to each worker to execute the work. You may obtain the travel and/or subsistence provisions for the current determinations on the [Director's General Prevailing Wage Determinations Website](http://www.dir.ca.gov/OPRL/DPreWageDetermination.htm) (<http://www.dir.ca.gov/OPRL/DPreWageDetermination.htm>). Travel and/or subsistence requirements for current or superseded determinations may be obtained by contacting the Office of the Director – Research Unit at (415) 703-4774.

Classifications:

Group 1

Bargeman
Brakeman
Compressor Operator
Ditchwitch, with seat or similar type equipment
Elevator Operator - Inside
Engineer Oiler
Forklift Operator (includes loed, lull or similar types – under 5 tons)
Generator Operator
Generator, Pump or Compressor Plant Operator
Heavy Duty Repairman Helper
Inertial Profiler Operator
Pump Operator
Signalman
Switchman

Group 2

Asphalt-Rubber Plant Operator (Nurse Tank Operator)
Coil Tubing Rig Operator
Concrete Mixer Operator – Skip Type
Conveyor Operator
Fireman
Forklift Operator (includes loed, lull or similar types – over 5 tons)
Hydrostatic Pump Operator
Oiler Crusher (Asphalt or Concrete Plant)
Petromat Laydown Machine
PJU Side Dump Jack
Rotary Drill Helper (Oilfield)
Screening and Conveyor Machine Operator (or similar types)
Skiploader (Wheel type up to ¾ yd. without attachment)
Tar Pot Fireman
Temporary Heating Plant Operator
Trenching Machine Oiler

Group 3

Asphalt Rubber Blend Operator
Bobcat or similar type (Skid Steer, with all attachments)
Equipment Greaser (rack)
Ford Ferguson (with dragtype attachments)
Helicopter Radioman (ground)

Stationary Pipe Wrapping and Cleaning Machine Operator

Group 4

Asphalt Plant Fireman
Backhoe Operator (mini-max or similar type)
Boring Machine Operator
Boring System Electronic Tracking Locator
Boxman or Mixerman (asphalt or concrete)
Chip Spreading Machine Operator
Concrete Cleaning Decontamination Machine Operator
Concrete Pump Operator (small portable)
Drilling Machine Operator, Small Auger types (Texoma Super Economatic, or similar types – Hughes 100 or 200, or similar types – drilling depth of 30 maximum)
Equipment Greaser (grease truck)
Excavator Track/Rubber-Tired-with all attachments (Operating weight under 21,000 lbs)
Guard Rail Post Driver Operator
Highline Cableway Signalman
Hydra-Hammer-Aero Stomper
Hydraulic Casing Oscillator Operator – drilling depth of 30' maximum
Micro Tunneling Operator (above ground tunnel)
Power Concrete Curing Machine Operator
Power Concrete Saw Operator
Power – Driver Jumbo Form Setter Operator
Power Sweeper Operator
Rock Wheel Saw/Trencher
Roller Operator (compacting)
Screed Operator (asphalt or concrete)
Trenching Machine Operator (up to 6 ft.)
Vacuum or Muck Truck

Group 5 (for multi-shift rate, see Pages 5 and 6)

Equipment Greaser (Grease Truck/Multi-Shift)

Group 6

Articulating Material Hauler
Asphalt Plant Engineer
Batch Plant Operator
Bit Sharpener
Concrete Joint Machine Operator (canal and similar type)
Concrete Placer Operator
Concrete Planer Operator

Dandy Digger
Deck Engine Operator
Deck Engineer
Derrickman (oilfield type)
Drilling Machine Operator, Bucket or Auger types
(Calweld 100 bucket or similar types – Watson
1000 auger or similar types – Texoma 330, 500 or
600 auger or similar types – drilling depth of 45'
maximum)
Drilling Machine Operator (including water wells)
Forced Feed Loader
Hydraulic Casing Oscillator Operator – drilling depth
of 45' maximum
Hydro Seeder Machine Operator (straw, pulp or seed)
Jackson Track Maintainer, or similar type
Kalamazoo Switch Tamper, or similar type
Machine Tool Operator
Maginnis Internal Full Slab Vibrator
Mechanical Berm, Curb or Gutter (concrete or
asphalt)
Mechanical Finisher Operator (concrete, Clary-
Johnson-Bidwell or similar)
Micro Tunnel System Operator (below ground)
Pavement Breaker Operator
Railcar Mover
Road Oil Mixing Machine Operator
Roller Operator (asphalt or finish)
Rubber-Tired Earthmoving Equipment (single
engine, up to and including 25 yds. struck)
Self-Propelled Tar Pipelining Machine Operator
Skiploader Operator (crawler and wheel type, over
 $\frac{3}{4}$ yds. and up to and including $1\frac{1}{2}$ yds.)
Slip Form Pump Operator (power driven hydraulic
lifting device for concrete forms)
Tractor Operator – Bulldozer, Tamper-Scraper
(single engine, up to 100 H.P. flyweel and similar
types, up to and including D-5 and similar types)
Tugger Hoist Operator (1 drum)
Ultra High Pressure Waterjet Cutting Tool System
Operator
Vacuum Blasting Machine Operator
Volumetric Mixer Operator
Welder - General

Group 7 (for multi-shift rate, see Pages 5 and 6)

Welder - General (Multi-Shift)

Group 8

Asphalt or Concrete Spreading Operator (tamping or
finishing)
Asphalt Paving Machine Operator (barber greene or
similar type, one (1) Screedman)
Asphalt-Rubber Distributor Operator
Backhoe Operator (up to and including $\frac{3}{4}$ yds.)
small ford, case or similar types
Backhoe Operator (over $\frac{3}{4}$ yd. and up to 5 cu. yds.
M.R.C.)
Barrier Rail Mover (BTM Series 200 or similar types)
Cast in Place Pipe Laying Machine Operator
Cold Foamed Asphalt Recycler
Combination Mixer and Compressor Operator
(gunite work)
Compactor Operator – Self Propelled
Concrete Mixer Operator – Paving
Crushing Plant Operator
Drill Doctor
Drilling Machine Operator, Bucket or Auger types
(Calweld 150 bucket or similar types – Watson
1500, 2000, 2500 auger or similar types –
Texoma 700, 800 auger or similar types – drilling
depth of 60' maximum)
Elevating Grader Operator
Excavator Track/Rubber-Tired with all attachments
(Operating Weight 21,000 lbs – 100,000 lbs)
Global Positioning System/GPS (or Technician)
Grade Checker
Gradall Operator
Grouting Machine Operator
Heavy Duty Repairman/Pump Installer
Heavy Equipment Robotics Operator
Hydraulic Casing Oscillator Operator – drilling depth
of 60' maximum
Hydraulic Operated Grout Plant (excludes hand
loading)
Kalamazoo Ballast Regulator or similar type
Klemm Drill Operator or similar types
Kolman Belt Loader and similar type
Le Tourneau Blob Compactor or similar type
Lo Drill
Loader Operator (Athey, Euclid, Sierra and similar
types)
Master Environmental Maintenance Mechanic
Mobark Chipper or similar types
Ozzie Padder or similar types
P.C. 490 Slot Saw

Pneumatic Concrete Placing Machine Operator
(Hackley-Presswell or similar type)
Prentice 721E Hydro-Ax
Pumpcrete Gun Operator
Rock Drill or Similar Types (see Miscellaneous
Provision #4 for additional information regarding
this classification)
Rotary Drill Operator (excluding caison type)
Rubber-Tired Earth Moving Equipment Operator
(single engine, caterpillar, euclid, athey wagon,
and similar types with any and all attachments
over 25 yds. and up to and including 50 cu yds.
struck)
Rubber-Tired Earth Moving Equipment Operator
(multiple engine – up to and including 25 yds.
struck)
Rubber-Tired Scraper Operator (self-loading paddle
wheel type – John Deere, 1040 and similar single
unit)
Self-Propelled Curb and Gutter Machine Operator
Shuttle Buggy
Skiploader Operator (crawler and wheel type over 1
½ yds. up to and including 6 ½ yds.)
Soil Remediation Plant Operator (CMI, Envirotech or
Similar)
Soil Stabilizer and Reclaimer (WR-2400)
Somero SXP Laser Screed
Speed Swing Operator
Surface Heaters and Planer Operator
Tractor Compressor Drill Combination Operator
Tractor Operator (any type larger than D-5 – 100
flyweel H.P. and over, or similar – bulldozer,
tamper, scraper and push tractor, single engine)
Tractor Operator (boom attachments)
Traveling Pipe Wrapping, Cleaning and Bending
Machine Operator)
Trenching Machine Operator (over 6 ft. depth
capacity, manufacturer's rating)
Trenching Machine with Road Miner Attachment
(over 6ft. depth capacity, manufacturer's rating –
Oiler or Journeyman Trainee required)
Ultra High Pressure Waterjet Cutting Tool System
Mechanic
Water Pull (compaction)

Group 9 (for multi-shift rate, see Pages 5 and 6)
Heavy Duty Repairman (Multi-Shift)

Group 10

Backhoe Operator (over 5 cu. yds. M.R.C.)
Drilling Machine Operator, Bucket or Auger types
(Calweld 200 B bucket or similar types – Watson
3000 or 5000 auger or similar types – Texoma
900 auger or similar types – drilling depth of 105'
maximum)
Dual Drum Mixer
Dynamic Compactor LDC350 or similar types
Heavy Duty Repairman-Welder combination
Hydraulic Casing Oscillator Operator – drilling depth
of 105' maximum
Monorail Locomotive Operator (diesel, gas or
electric)
Motor Patrol – Blade Operator (single engine)
Multiple Engine Tractor Operator (euclid and similar
type – except quad 9 cat.)
Pneumatic Pipe Ramming Tool and similar types
Pre-stressed Wrapping Machine Operator (2
Operators required)
Rubber – Tired Earth Moving Equipment Operator
(single engine, over 50 yds. struck)
Rubber – Tired Earth Moving Equipment Operator
(multiple engine, euclid caterpillar and similar –
over 25 yds. and up to 50 yds. struck)
Tower Crane Repairman
Tractor Loader Operator (crawler and wheel-type
over 6 ½ yds.)
Unmanned Aircraft Systems (UAS Drones) Operator
(when used in conjunction with hoisting and
placing materials)
Welder – Certified
Woods Mixer Operator (and similar pugmill
equipment)

Group 11 (for multi-shift rate, see Pages 5 and 6)

Heavy Duty Repairman – Welder Combination
(Multi-Shift)
Welder – Certified (Multi-Shift)

Group 12

Auto Grader Operator
Automatic Slip Form Operator
Backhoe Operator (over 7 cu. yds. M.R.C.)
Drilling Machine Operator, Bucket or Auger types
(Calweld, auger 200 CA or similar types –
Watson, auger 6000 or similar types – hughes
super duty, auger 200 or similar types – drilling
depth of 175' maximum)

Excavator Track/Rubber Tired- with all attachments
(Operating Weight 100,000 lbs. – 200,000 lbs.)
Hoe Ram or similar with compressor
Hydraulic Casing Oscillator Operator – drilling depth
of 175' maximum
Mass Excavator Operator – less than 750 cu. yds.
Mechanical Finishing Machine Operator
Mobile Form Traveler Operator
Motor Patrol Operator (multi-engine)
Pipe Mobile Machine Operator
Rubber-Tired Earth Moving Equipment Operator
(multiple engine, euclid, caterpillar and similar
type, over 50 cu. yds. struck)
Rubber-Tired Self-Loading Scraper Operator
(paddle-wheel-auger type self-loading – (two (2)
or more units)

Group 13

Rubber-Tired Earth Moving Equipment Operator,
Operating Equipment with the Push-Pull System
(single engine, up to and including 25 yds. struck)

Group 14

Canal Liner Operator
Canal Trimmer Operator
Drilling Machine Operator, Bucket or Auger types
(Calweld, auger 200 CA or similar types –
watson, auger 6000 or similar types – hughes
super duty, auger 200 or similar types – drilling
depth of 300' maximum)
Remote Controlled Earth Moving Operator (\$1.00
per hour additional to base rate)
Wheel Excavator Operator (over 750 cu. yds. per
hour)

Group 15

Rubber-Tired Earth Moving Equipment Operator,
Operating Equipment with the Push-Pull System
(single engine, caterpillar, euclid, athey wagon,
and similar types with any and all attachments
over 25 and up to and including 50 cu. yds.
struck)
Rubber-Tired Earth Moving Equipment Operator,
Operating Equipment with the Push-Pull System
(multiple engine - up to and including 25 yds.
struck)

Group 16

Excavator Track/Rubber Tired – with all attachments
(Operating Weight exceeding 200,000 lbs.)

Rubber-Tired Earth Moving Equipment Operator,
Operating Equipment with the Push-Pull System
(single engine, over 50 yds. struck)
Rubber-Tired Earth Moving Equipment Operator,
Operating Equipment with the Push-Pull System
(multiple engine, euclid, caterpillar, and similar,
over 25 yds. and up to 50 yds. struck)

Group 17

Rubber-Tired Earth Moving Equipment Operator,
Operating Equipment with the Push-Pull System
(multiple engine, euclid, caterpillar, and similar
type, over 50 cu. yds. struck)
Tandem Tractor Operator (operating crawler type
tractors in tandem – Quad 9 and similar type)

Group 18

Rubber-Tired Earth Moving Equipment Operator,
Operating in Tandem (scrapers, belly dumps, and
similar types in any combination, excluding
compaction units - single engine, up to and
including 25 yds. struck)

Group 19

Rotex Concrete Belt Operator
Rubber-Tired Earth Moving Equipment Operator,
Operating in Tandem (scrapers, belly dumps, and
similar types in any combination, excluding
compaction units - single engine, caterpillar,
euclid, athey wagon, and similar types with any
and all attachments over 25 yds. and up to and
including 50 cu. yds. struck)
Rubber-Tired Earth Moving Equipment Operator,
Operating in Tandem (scrapers, belly dumps, and
similar types in any combination, excluding
compaction units - multiple engines, up to and
including 25 yds. struck)

Group 20

Rubber-Tired Earth Moving Equipment Operator,
Operating in Tandem (scrapers, belly dumps, and
similar types in any combination, excluding
compaction units - single engine, over 50 yds.
struck)
Rubber-Tired Earth Moving Equipment Operator,
Operating in Tandem (scrapers, belly dumps, and
similar types in any combination, excluding
compaction units - multiple engine, euclid,
caterpillar and similar, over 25 yds. and up to 50
yds. struck)

Group 21

Rubber-Tired Earth Moving Equipment Operator, Operating in Tandem (scrapers, belly dumps, and similar types in any combination, excluding compaction units - multiple engine, euclid, caterpillar and similar type, over 50 cu. yds. struck)

Group 22

Rubber-Tired Earth Moving Equipment Operator, Operating Equipment with the Tandem Push-Pull System (single engine, up to and including 25 yds. struck)

Group 23

Rubber-Tired Earth Moving Equipment Operator, Operating Equipment with the Tandem Push-Pull System (single engine, caterpillar, euclid, athey wagon, and similar types with any and all attachments over 25 yds. and up to and including 50 cu. yds. struck)

Rubber-Tired Earth Moving Equipment Operator, Operating Equipment with the Tandem Push-Pull System (multiple engine, up to and including 25 yds. struck)

Group 24

Rubber-Tired Earth Moving Equipment Operator, Operating Equipment with the Tandem Push-Pull System (single engine, over 50 yds. Struck)
Rubber-Tired Earth Moving Equipment Operator, Operating Equipment with the Tandem Push-Pull System (multiple engine, euclid, caterpillar and similar, over 25 yds. and up to 50 yds. struck)

Group 25

Concrete Pump Operator-Truck Mounted Pedestal Concrete Pump Operator
Rubber-Tired Earth Moving Equipment Operator, Operating Equipment with the Tandem Push-Pull System (multiple engine, euclid, caterpillar and similar over 50 cu. yds struck)

MISCELLANEOUS PROVISIONS:

1. Operators on hoists with three drums shall receive fifty cents (50¢) per hour additional pay to the regular rate of pay. The additional pay shall be added to the regular rate and become the base rate for the entire shift.
2. All heavy duty repairman and heavy duty combination shall receive one dollar (\$1.00) per hour tool allowance in addition to their regular rate of pay and this shall become their base rate of pay.
3. Employees required to suit up and work in a hazardous material environment, shall receive Two Dollars (\$2.00) per hour in addition to their regular rate of pay, and that rate shall become the basic hourly rate of pay.
4. A review of rock drilling is currently pending. The minimum acceptable rate of pay for this classification or type of work on public works projects is Laborer and Related Classifications/Group 5 (Driller) as published in the Director's General Prevailing Wage Determinations. However, the published rate for the craft/classification of Operating Engineer/Group 8 (Rock Drill or Similar Types) may be used by contractors to perform rock drilling on public works projects.

Indicates an apprenticeable craft. The current apprentice wage rates are available on the [Prevailing Wage Apprentice Determinations Website](http://www.dir.ca.gov/OPRL/PWAppWage/PWAppWageStart.asp) (<http://www.dir.ca.gov/OPRL/PWAppWage/PWAppWageStart.asp>).

^a For classifications within each group, see Pages 7 through 11.

^b Rate applies to the first 4 overtime hours. All other daily overtime is paid at the Sunday rate.

^c Rate applies to the first 12 hours worked. All other time is paid at the Sunday rate.

^d Includes an amount for Annuity.

^e Includes an amount withheld for supplemental dues.

^f The Third Shift shall work 6.5 hours, exclusive of meal period, for which 8 hours straight-time shall be paid at the non-shift rate, Monday through Friday.

GENERAL PREVAILING WAGE DETERMINATION MADE BY THE DIRECTOR OF INDUSTRIAL RELATIONS
PURSUANT TO CALIFORNIA LABOR CODE PART 7, CHAPTER 1, ARTICLE 2, SECTIONS 1770, 1773 AND 1773.1
FOR COMMERCIAL BUILDING, HIGHWAY, HEAVY CONSTRUCTION AND DREDGING PROJECTS

Craft: Parking and Highway Improvement (Striping, Slurry and Seal Coat Operations-Laborer)#

Determination:

SC-23-102-6-2023-2

Issue Date:

August 22, 2023

Expiration date of determination:

June 30, 2024** The rate to be paid for work performed after this date has been determined. If work will extend past this date, the new rate must be paid and should be incorporated in contracts entered into now. Contact the Office of the Director - Research Unit for specific rates at (415) 703-4774.

Localities:

All localities within Imperial, Inyo, Kern, Los Angeles, Mono, Orange, Riverside, San Bernardino, San Diego, San Luis Obispo, Santa Barbara and Ventura Counties.

Wages and Employer Payments:

Classification ^a (Journey person)	Basic Hourly Rate	Health and Welfare	Pension	Vacation/ Holiday ^b	Training	Other	Hours ^c	Total Hourly Rate	Daily Overtime Hourly Rate (1 ½ X)	6 th & 7 th Day Overtime Hourly Rate ^d (1½ x)	Holiday Overtime Hourly Rate (2 X)
Group 1	\$44.10	\$8.95	\$8.57	\$5.26	\$1.42	\$0.56	8.0	\$68.86	\$90.910	\$90.910	\$112.96
Group 2	\$45.40	\$8.95	\$8.57	\$5.26	\$1.42	\$0.56	8.0	\$70.16	\$92.860	\$92.860	\$115.56
Group 3	\$47.41	\$8.95	\$8.57	\$5.26	\$1.42	\$0.56	8.0	\$72.17	\$95.875	\$95.875	\$119.58
Group 4	\$49.15	\$8.95	\$8.57	\$5.26	\$1.42	\$0.56	8.0	\$73.91	\$98.485	\$98.485	\$123.06

Recognized holidays:

Holidays upon which the general prevailing hourly wage rate for Holiday work shall be paid, shall be all holidays in the collective bargaining agreement, applicable to the particular craft, classification, or type of worker employed on the project, which is on file with the Director of Industrial Relations. If the prevailing rate is not based on a collectively bargained rate, the holidays upon which the prevailing rate shall be paid shall be as provided in Section 6700 of the Government Code. You may obtain the holiday provisions for the current determinations on the [Director's General Prevailing Wage Determinations Website](http://www.dir.ca.gov/OPRL/DPreWageDetermination.htm) (<http://www.dir.ca.gov/OPRL/DPreWageDetermination.htm>). Holiday provisions for current or superseded determinations may be obtained by contacting the Office of the Director – Research Unit at (415) 703-4774.

Travel and/or subsistence payment:

In accordance with Labor Code Sections 1773.1 and 1773.9, contractors shall make travel and/or subsistence payments to each worker to execute the work. You may obtain the travel and/or subsistence provisions for the current determinations on the [Director's General Prevailing Wage Determinations Website](http://www.dir.ca.gov/OPRL/DPreWageDetermination.htm) (<http://www.dir.ca.gov/OPRL/DPreWageDetermination.htm>). Travel and/or subsistence requirements for current or superseded determinations may be obtained by contacting the Office of the Director – Research Unit at (415) 703-4774.

CLASSIFICATION GROUPS:

Group 1

Protective coating, Pavement sealing (repairs and filling of cracks by any method to parking lots, game courts and playgrounds, and tracks, whether indoor or outdoor)
Truck Mounted Attenuator
Automatous Truck Mounted Attenuator
Installation of carstops
Traffic Control Person & Serviceman; including work of installing and protecting utility covers, traffic delineating devices, posting of no parking and notifications for public convenience
Asphalt Repair
Equipment Repair Technician
Truncated Dome Assitant
Decorative Asphalt Surfacing Applicator Assistant

Group 2

Traffic Surface Abrasive Blaster
Pot Tender
Traffic Control Person/Certified Traffic Control Person
Repairing and filling of cracks and surface cleaning on streets, highways, and airports by any means, and other work not directly connected with the application of slurry seal
Slurry Seal Squeegeeman (finisher)
Bob Cat/Skid Steer
Seal Roller
Forklift

Group 3

Traffic Delineating Device Applicator
Traffic Protective System Installer
Pavement Marking Applicator

Slurry Seal Applicator Operator (Line Driver- including self-contained distribution units, aggregate spreader truck)
Shuttleman (loader/slurry machine operations) operation of all related machinery and equipment; handling of related materials
Truncated Dome Technician
Decorative Asphalt Surfacing Applicator

Group 4

Traffic Striping Applicator
Slurry Seal Mixer Operator
Power Broom Sweeper (operation of all related trucks, machinery and equipment; Handling of related materials)

Indicates an apprenticeable craft. The current apprentice wage rates are available on the [Prevailing Wage Apprentice Determinations Website](http://www.dir.ca.gov/OPRL/PWAppWage/PWAppWageStart.asp) (<http://www.dir.ca.gov/OPRL/PWAppWage/PWAppWageStart.asp>).

^a For classifications within each group, see Page 2.

^b Includes an amount per hour worked for Supplemental Dues.

^c Straight-time hours: 8 consecutive hours per day. 40 hours over 5 consecutive days, Monday through Sunday shall constitute a week's work at straight time.

^d The sixth consecutive day in the same work week may be worked at straight-time if job is shut down during work week due to inclement weather.

GENERAL PREVAILING WAGE DETERMINATION MADE BY
 THE DIRECTOR OF INDUSTRIAL RELATIONS PURSUANT TO CALIFORNIA LABOR CODE
 PART 7, CHAPTER 1, ARTICLE 2, SECTIONS 1770, 1773 AND 1773.1
 FOR COMMERCIAL BUILDING, HIGHWAY, HEAVY CONSTRUCTION AND DREDGING PROJECTS

CRAFT: #TEAMSTER (APPLIES ONLY TO WORK ON THE CONSTRUCTION SITE)

Determination:

SC-23-261-2-2023-1

Issue Date:

August 22, 2023

Expiration date of determination:

June 30, 2024** The rate to be paid for work performed after this date has been determined. If work will extend past this date, the new rate must be paid and should be incorporated in contracts entered into now. Contact the Office of the Director – Research Unit for specific rates at (415) 703-4774.

Localities:

All localities within Imperial, Inyo, Kern, Los Angeles, Mono, Orange, Riverside, San Bernardino, San Luis Obispo, Santa Barbara and Ventura Counties.

Wages and total hourly rates (including employer payments):

Classification ^a (Journey person)	Basic Hourly Rate	Hours	Total Hourly Rate	Daily Overtime Hourly Rate ^b (1½ x)	Saturday Overtime Hourly Rate ^b (1½ x)	Sunday/Holiday Overtime Hourly Rate (2 x)
Group I	\$38.19	8	\$71.88	\$90.975	\$90.975	\$110.07
Group II	\$38.34	8	\$72.03	\$91.20	\$91.20	\$110.37
Group III	\$38.47	8	\$72.16	\$91.395	\$91.395	\$110.63
Group IV	\$38.66	8	\$72.35	\$91.68	\$91.68	\$111.01
Group V	\$38.69	8	\$72.38	\$91.725	\$91.725	\$111.07
Group VI	\$38.72	8	\$72.41	\$91.77	\$91.77	\$111.13
Group VII	\$38.97	8	\$72.66	\$92.145	\$92.145	\$111.63
Group VIII	\$39.22	8	\$72.91	\$92.52	\$92.52	\$112.13
Group IX	\$39.42	8	\$73.11	\$92.82	\$92.82	\$112.53
Group X	\$39.72	8	\$73.41	\$93.27	\$93.27	\$113.13
Group XI	\$40.22	8	\$73.91	\$94.02	\$94.02	\$114.13

Employer Payments:

Type of Fund	Amount per Hour
Health and Welfare	\$20.12
Pension	\$8.00
Vacation and Holiday ^c	\$3.15
Training	\$1.92
Other	\$0.50

Wages and total hourly rates (including employer payments):

Classification ^d (Subjourneyman)	Basic Hourly Rate	Hours	Total Hourly Rate	Daily Overtime Hourly Rate ^b (1½ x)	Saturday Overtime Hourly Rate ^b (1½x)	Sunday/Holiday Overtime Hourly Rate (2 x)
0-2000 hours	\$24.40	8	\$56.94	\$69.14	\$69.14	\$81.34
2001-4000 hours	\$26.40	8	\$59.19	\$72.39	\$72.39	\$85.59
4001-6000 hours	\$28.40	8	\$61.44	\$75.64	\$75.64	\$89.84

Over 6000 hours and thereafter at journeyman rates.

Employer Payments:

Type of Fund	Amount per Hour
Health and Welfare	\$20.12
Pension	\$8.00
Vacation and Holiday ^c	\$2.00 (\$2.25 for 2001-4000 hours; \$2.50 for 4001-6000 hours)
Training	\$1.92
Other	\$0.50

Recognized holidays:

Holidays upon which the general prevailing hourly wage rate for Holiday work shall be paid, shall be all holidays in the collective bargaining agreement, applicable to the particular craft, classification, or type of worker employed on the project, which is on file with the Director of Industrial Relations. If the prevailing rate is not based on a collectively bargained rate, the holidays upon which the prevailing rate shall be paid shall be as provided in Section 6700 of the Government Code. You may obtain the holiday provisions for the current determinations on the [Director's General Prevailing Wage Determinations Website](http://www.dir.ca.gov/OPRL/DPreWageDetermination.htm) (<http://www.dir.ca.gov/OPRL/DPreWageDetermination.htm>). Holiday provisions for current or superseded determinations may be obtained by contacting the Office of the Director – Research Unit at (415) 703-4774.

Travel and/or subsistence payment:

In accordance with Labor Code Sections 1773.1 and 1773.9, contractors shall make travel and/or subsistence payments to each worker to execute the work. You may obtain the travel and/or subsistence provisions for the current determinations on the [Director's General Prevailing Wage Determinations Website](http://www.dir.ca.gov/OPRL/DPreWageDetermination.htm) (<http://www.dir.ca.gov/OPRL/DPreWageDetermination.htm>). Travel and/or subsistence requirements for current or superseded determinations may be obtained by contacting the Office of the Director – Research Unit at (415) 703-4774.

GENERAL PREVAILING WAGE DETERMINATION MADE BY
THE DIRECTOR OF INDUSTRIAL RELATIONS PURSUANT TO CALIFORNIA LABOR CODE
PART 7, CHAPTER 1, ARTICLE 2, SECTIONS 1770, 1773 AND 1773.1
FOR COMMERCIAL BUILDING, HIGHWAY, HEAVY CONSTRUCTION AND DREDGING PROJECTS

**CRAFT: #TEAMSTER (SPECIAL SHIFT)
(APPLIES ONLY TO WORK ON THE CONSTRUCTION SITE)**

Determination:

SC-23-261-2-2023-1

Issue Date:

August 22, 2023

Expiration date of determination:

June 30, 2024** The rate to be paid for work performed after this date has been determined. If work will extend past this date, the new rate must be paid and should be incorporated in contracts entered into now. Contact the Office of the Director – Research Unit for specific rates at (415) 703-4774.

Localities:

All localities within Imperial, Inyo, Kern, Los Angeles, Mono, Orange, Riverside, San Bernardino, San Luis Obispo, Santa Barbara and Ventura Counties.

Wages and total hourly rates (including employer payments):

Classification ^a (Journey person)	Basic Hourly Rate	Hours	Total Hourly Rate	Daily Overtime Hourly Rate ^b (1½ x)	Saturday Overtime Hourly Rate ^b (1½ x)	Sunday/Holiday Overtime Hourly Rate (2 x)
Group I	\$39.19	8	\$72.88	\$92.475	\$92.475	\$112.07
Group II	\$39.34	8	\$73.03	\$92.70	\$92.70	\$112.37
Group III	\$39.47	8	\$73.16	\$92.895	\$92.895	\$112.63
Group IV	\$39.66	8	\$73.35	\$93.18	\$93.18	\$113.01
Group V	\$39.69	8	\$73.38	\$93.225	\$93.225	\$113.07
Group VI	\$39.72	8	\$73.41	\$93.27	\$93.27	\$113.13
Group VII	\$39.97	8	\$73.66	\$93.645	\$93.645	\$113.63
Group VIII	\$40.22	8	\$73.91	\$94.02	\$94.02	\$114.13
Group IX	\$40.42	8	\$74.11	\$94.32	\$94.32	\$114.53
Group X	\$40.72	8	\$74.41	\$94.77	\$94.77	\$115.13
Group XI	\$41.22	8	\$74.91	\$95.52	\$95.52	\$116.13

Employer Payments:

Type of Fund	Amount per Hour
Health and Welfare	\$20.12
Pension	\$8.00
Vacation and Holiday ^c	\$3.15
Training	\$1.92
Other	\$0.50

Wages and total hourly rates (including employer payments):

Classification ^d (Subjourneyman)	Basic Hourly Rate	Hours	Total Hourly Rate	Daily Overtime Hourly Rate ^b (1½ x)	Saturday Overtime Hourly Rate ^b (1½x)	Sunday/Holiday Overtime Hourly Rate (2 x)
0-2000 hours	\$24.40	8	\$56.94	\$69.14	\$69.14	\$81.34
2001-4000 hours	\$26.40	8	\$59.19	\$72.39	\$72.39	\$85.59
4001-6000 hours	\$28.40	8	\$61.44	\$75.64	\$75.64	\$89.84

Over 6000 hours and thereafter at journeyman rates.

Employer Payments:

Type of Fund	Amount per Hour
Health and Welfare	\$20.12
Pension	\$8.00
Vacation and Holiday ^c	\$2.00 (\$2.25 for 2001-4000 hours; \$2.50 for 4001-6000 hours)
Training	\$1.92
Other	\$0.50

Recognized holidays:

Holidays upon which the general prevailing hourly wage rate for Holiday work shall be paid, shall be all holidays in the collective bargaining agreement, applicable to the particular craft, classification, or type of worker employed on the project, which is on file with the Director of Industrial Relations. If the prevailing rate is not based on a collectively bargained rate, the holidays upon which the prevailing rate shall be paid shall be as provided in Section 6700 of the Government Code. You may obtain the holiday provisions for the current determinations on the [Director's General Prevailing Wage Determinations Website](http://www.dir.ca.gov/OPRL/DPreWageDetermination.htm) (<http://www.dir.ca.gov/OPRL/DPreWageDetermination.htm>). Holiday provisions for current or superseded determinations may be obtained by contacting the Office of the Director – Research Unit at (415) 703-4774.

Travel and/or subsistence payment:

In accordance with Labor Code Sections 1773.1 and 1773.9, contractors shall make travel and/or subsistence payments to each worker to execute the work. You may obtain the travel and/or subsistence provisions for the current determinations on the [Director's General Prevailing Wage Determinations Website](http://www.dir.ca.gov/OPRL/DPreWageDetermination.htm) (<http://www.dir.ca.gov/OPRL/DPreWageDetermination.htm>). Travel and/or subsistence requirements for current or superseded determinations may be obtained by contacting the Office of the Director – Research Unit at (415) 703-4774.

GENERAL PREVAILING WAGE DETERMINATION MADE BY
THE DIRECTOR OF INDUSTRIAL RELATIONS PURSUANT TO CALIFORNIA LABOR CODE
PART 7, CHAPTER 1, ARTICLE 2, SECTIONS 1770, 1773 AND 1773.1
FOR COMMERCIAL BUILDING, HIGHWAY, HEAVY CONSTRUCTION AND DREDGING PROJECTS

**CRAFT: #TEAMSTER (SECOND SHIFT)
(APPLIES ONLY TO WORK ON THE CONSTRUCTION SITE)**

Determination:

SC-23-261-2-2023-1

Issue Date:

August 22, 2023

Expiration date of determination:

June 30, 2024** The rate to be paid for work performed after this date has been determined. If work will extend past this date, the new rate must be paid and should be incorporated in contracts entered into now. Contact the Office of the Director – Research Unit for specific rates at (415) 703-4774.

Localities:

All localities within Imperial, Inyo, Kern, Los Angeles, Mono, Orange, Riverside, San Bernardino, San Luis Obispo, Santa Barbara and Ventura Counties.

Wages and total hourly rates (including employer payments):

Classification ^a (Journey person)	Basic Hourly Rate	Hours ^e	Total Hourly Rate	Daily Overtime Hourly Rate ^b (1½ x)	Saturday Overtime Hourly Rate ^b (1½ x)	Sunday/Holiday Overtime Hourly Rate (2 x)
Group I	\$40.19	8	\$73.88	\$93.975	\$93.975	\$114.07
Group II	\$40.34	8	\$74.03	\$94.20	\$94.20	\$114.37
Group III	\$40.47	8	\$74.16	\$94.395	\$94.395	\$114.63
Group IV	\$40.66	8	\$74.35	\$94.68	\$94.68	\$115.01
Group V	\$40.69	8	\$74.38	\$94.725	\$94.725	\$115.07
Group VI	\$40.72	8	\$74.41	\$94.77	\$94.77	\$115.13
Group VII	\$40.97	8	\$74.66	\$95.145	\$95.145	\$115.63
Group VIII	\$41.22	8	\$74.91	\$95.52	\$95.52	\$116.13
Group IX	\$41.42	8	\$75.11	\$95.82	\$95.82	\$116.53
Group X	\$41.72	8	\$75.41	\$96.27	\$96.27	\$117.13
Group XI	\$42.22	8	\$75.91	\$97.02	\$97.02	\$118.13

Employer Payments:

Type of Fund	Amount per Hour
Health and Welfare	\$20.12
Pension	\$8.00
Vacation and Holiday ^c	\$3.15
Training	\$1.92
Other	\$0.50

Wages and total hourly rates (including employer payments):

Classification ^d (Subjourneyman)	Basic Hourly Rate	Hours	Total Hourly Rate	Daily Overtime Hourly Rate ^b (1½ x)	Saturday Overtime Hourly Rate ^b (1½x)	Sunday/Holiday Overtime Hourly Rate (2 x)
0-2000 hours	\$24.40	8	\$56.94	\$69.14	\$69.14	\$81.34
2001-4000 hours	\$26.40	8	\$59.19	\$72.39	\$72.39	\$85.59
4001-6000 hours	\$28.40	8	\$61.44	\$75.64	\$75.64	\$89.84

Over 6000 hours and thereafter at journeyman rates.

Employer Payments:

Type of Fund	Amount per Hour
Health and Welfare	\$20.12
Pension	\$8.00
Vacation and Holiday ^c	\$2.00 (\$2.25 for 2001-4000 hours; \$2.50 for 4001-6000 hours)
Training	\$1.92
Other	\$0.50

Recognized holidays:

Holidays upon which the general prevailing hourly wage rate for Holiday work shall be paid, shall be all holidays in the collective bargaining agreement, applicable to the particular craft, classification, or type of worker employed on the project, which is on file with the Director of Industrial Relations. If the prevailing rate is not based on a collectively bargained rate, the holidays upon which the prevailing rate shall be paid shall be as provided in Section 6700 of the Government Code. You may obtain the holiday provisions for the current determinations on the [Director's General Prevailing Wage Determinations Website](http://www.dir.ca.gov/OPRL/DPreWageDetermination.htm) (<http://www.dir.ca.gov/OPRL/DPreWageDetermination.htm>). Holiday provisions for current or superseded determinations may be obtained by contacting the Office of the Director – Research Unit at (415) 703-4774.

Travel and/or subsistence payment:

In accordance with Labor Code Sections 1773.1 and 1773.9, contractors shall make travel and/or subsistence payments to each worker to execute the work. You may obtain the travel and/or subsistence provisions for the current determinations on the [Director's General Prevailing Wage Determinations Website](http://www.dir.ca.gov/OPRL/DPreWageDetermination.htm) (<http://www.dir.ca.gov/OPRL/DPreWageDetermination.htm>). Travel and/or subsistence requirements for current or superseded determinations may be obtained by contacting the Office of the Director – Research Unit at (415) 703-4774.

Classifications:

Group I Warehouseman and Teamster	Side Dump Trucks Flow Boy Dump Trucks
Group II Driver of Vehicle or Combination of Vehicles - 2 axles Traffic Control Pilot Car, excluding moving heavy equipment permit load Truck Mounted Power Broom	Group VII A Frame, Swedish Crane or Similar Forklift Driver Ross Carrier Driver
Group III Driver of Vehicle or Combination of Vehicles - 3 axles Bootman Cement Mason Distribution Truck Fuel Truck Driver Water Truck - 2 axles Dump Truck of less than 16 yards water level Erosion Control Driver	Group VIII Dump Truck of 25 yds to 49 yards water level Truck Repairman Water Pull Single Engine Welder
Group IV Driver of Transit Mix Truck-Under 3 yds Dumpcrete Truck Less than 6½ yards water level Truck Repairman Helper	Group IX Truck Repairman Welder Low Bed Driver, 9 axles or over
Group V Water Truck 3 or more axles Warehouseman Clerk Slurry Truck Driver	Group X Working Truck Driver Truck Greaser and Tireman - \$0.50 additional for Tireman Pipeline and Utility Working Truck Driver, including Winch Truck and Plastic Fusion, limited to Pipeline and Utility Work Dump Truck and Articulating - 50 yards or more water level Water Pull Single Engine with attachment
Group VI Driver of Transit Mix Truck - 3 yds or more Dumpcrete Truck 6½ yds water level and over Driver of Vehicle or Combination of Vehicles - 4 or more axles Driver of Oil Spreader Truck Dump Truck 16 yds to 25 yds water level	Group XI Water Pull Twin Engine Water Pull Twin Engine with attachments Winch Truck Driver - \$0.25 additional when operating a Winch or similar special attachment

Indicates an apprenticeable craft. The current apprentice wage rates are available on the [Prevailing Wage Apprentice Determinations Website](http://www.dir.ca.gov/OPRL/PWAppWage/PWAppWageStart.asp) (<http://www.dir.ca.gov/OPRL/PWAppWage/PWAppWageStart.asp>).

^a For classifications within each group, see Page 7.

^b Rate applies to the first 4 daily overtime hours on weekdays and the first 12 hours on Saturday. All other overtime is paid at the Sunday/Holiday double-time rate.

^c Includes an amount for Supplemental Dues.

^d Subjourneymen may be employed at a ratio of one subjourneyman for every five journeymen.

^e The third shift shall work 6.5 hours, exclusive of meal period, for which 8-hours straight time shall be paid at the non-shift rate, Monday through Friday.

GENERAL PREVAILING WAGE DETERMINATION MADE BY THE DIRECTOR OF INDUSTRIAL RELATIONS
PURSUANT TO CALIFORNIA LABOR CODE PART 7, CHAPTER 1, ARTICLE 2, SECTIONS 1770, 1773 AND 1773.1
FOR COMMERCIAL BUILDING, HIGHWAY, HEAVY CONSTRUCTION AND DREDGING PROJECTS

Craft: TREE MAINTENANCE (LABORER) ¹

(APPLIES ONLY TO ROUTINE TREE MAINTENANCE WORK, NOT CONSTRUCTION AND/OR LANDSCAPE CONSTRUCTION) ²

Determination:

SC-102-X-20-2023-1

Issue Date:

August 22, 2023

Expiration date of determination:

June 30, 2024** The rate to be paid for work performed after this date has been determined. If work will extend past this date, the new rate must be paid and should be incorporated in contracts entered into now. Contact the Office of the Director - Research Unit for specific rates at (415) 703-4774.

Localities:

All localities within Imperial, Inyo, Kern, Los Angeles, Mono, Orange, Riverside, San Bernardino, San Diego, San Luis Obispo, Santa Barbara and Ventura Counties.

Wages and Employer Payments:

Classification ^a (Journey person)	Basic Hourly Rate	Health and Welfare	Pension	Vacation and Holiday	Training	Other	Hours	Total Hourly Rate	Daily Overtime Hourly Rate ^b (1 ½ X)	Sunday/Holiday Overtime Hourly Rate (2 X)
Senior Tree Trimmer	\$25.19	\$3.50	\$2.26	\$2.47	\$0.00	\$0.30	8.0	\$33.72	\$46.315	\$58.91
Tree Trimmer	\$23.19	\$3.50	\$2.26	\$2.27	\$0.00	\$0.30	8.0	\$31.52	\$43.115	\$54.71
Groundperson	\$21.55	\$3.50	\$2.26	\$2.12	\$0.00	\$0.30	8.0	\$29.73	\$40.505	\$51.28

Recognized holidays:

Holidays upon which the general prevailing hourly wage rate for Holiday work shall be paid, shall be all holidays in the collective bargaining agreement, applicable to the particular craft, classification, or type of worker employed on the project, which is on file with the Director of Industrial Relations. If the prevailing rate is not based on a collectively bargained rate, the holidays upon which the prevailing rate shall be paid shall be as provided in Section 6700 of the Government Code. You may obtain the holiday provisions for the current determinations on the [Director's General Prevailing Wage Determinations Website](http://www.dir.ca.gov/OPRL/DPreWageDetermination.htm) (http://www.dir.ca.gov/OPRL/DPreWageDetermination.htm). Holiday provisions for current or superseded determinations may be obtained by contacting the Office of the Director – Research Unit at (415) 703-4774.

Travel and/or subsistence payment:

In accordance with Labor Code Sections 1773.1 and 1773.9, contractors shall make travel and/or subsistence payments to each worker to execute the work. You may obtain the travel and/or subsistence provisions for the current determinations on the [Director's General Prevailing Wage Determinations Website](http://www.dir.ca.gov/OPRL/DPreWageDetermination.htm) (<http://www.dir.ca.gov/OPRL/DPreWageDetermination.htm>). Travel and/or subsistence requirements for current or superseded determinations may be obtained by contacting the Office of the Director – Research Unit at (415) 703-4774.

¹ This determination does not apply to the work of a landscape laborer employed on landscape construction (work incidental to construction or post-construction maintenance during the plant installation and establishment period) or to tree trimming work involving line clearance.

² This determination does not apply to the work of a landscape laborer employed on landscape construction (work incidental to construction or post-construction maintenance during the plant installation and establishment period) or to tree trimming work involving line clearance.

^a There shall be at least one Senior Tree Trimmer on crews of three or more.

^b Monday thru Saturday shall constitute a workweek. Rate applies to first 4 overtime hours Monday thru Saturday, and all time worked in excess of forty (40) hours per workweek. All other time is paid at the Sunday and Holiday double-time rate.

NOT FOR BIDD

GENERAL PREVAILING WAGE DETERMINATION MADE BY THE DIRECTOR OF INDUSTRIAL RELATIONS
PURSUANT TO CALIFORNIA LABOR CODE PART 7, CHAPTER 1, ARTICLE 2, SECTIONS 1770, 1773 AND 1773.1
FOR COMMERCIAL BUILDING, HIGHWAY, HEAVY CONSTRUCTION AND DREDGING PROJECTS

CRAFT: TUNNEL WORKER (LABORER)

Determination:

SC-23-102-12-2023-1

Issue Date:

August 22, 2023

Expiration date of determination:

June 30, 2024** The rate to be paid for work performed after this date has been determined. If work will extend past this date, the new rate must be paid and should be incorporated in contracts entered into now. Contact the Office of the Director - Research Unit for specific rates at (415) 703-4774.

Localities:

All localities within Imperial, Inyo, Kern, Los Angeles, Mono, Orange, Riverside, San Bernardino, San Luis Obispo, Santa Barbara, and Ventura Counties.

Wages and Employer Payments:

Classification ^a (Journey person)	Basic Hourly Rate	Health and Welfare	Pension	Vacation/ Holiday ^b	Training	Other	Hours	Total Hourly Rate	Daily Overtime Hourly Rate ^c (1½ X)	Saturday Overtime Hourly Rate ^c (1½ X)	Sunday/ Holiday Overtime Hourly Rate (2 X)
Group I	\$48.03	\$8.95	\$11.62	\$5.02	\$0.75	\$0.67	8	\$75.040	\$99.055	\$99.055	\$123.070
Group II	\$48.35	\$8.95	\$11.62	\$5.02	\$0.75	\$0.67	8	\$75.360	\$99.535	\$99.535	\$123.710
Group III	\$48.81	\$8.95	\$11.62	\$5.02	\$0.75	\$0.67	8	\$75.820	\$100.225	\$100.225	\$124.630
Group IV ^d	\$49.50	\$8.95	\$11.62	\$5.02	\$0.75	\$0.67	8	\$76.510	\$101.260	\$101.260	\$126.010
Group V	\$50.35	\$8.95	\$11.62	\$5.02	\$0.75	\$0.67	8	\$77.360	\$102.535	\$102.535	\$127.710

Recognized holidays:

Holidays upon which the general prevailing hourly wage rate for Holiday work shall be paid, shall be all holidays in the collective bargaining agreement, applicable to the particular craft, classification, or type of worker employed on the project, which is on file with the Director of Industrial Relations. If the prevailing rate is not based on a collectively bargained rate, the holidays upon which the prevailing rate shall be paid shall be as provided in Section 6700 of the Government Code. You may obtain the holiday provisions for the current determinations on the [Director's General Prevailing Wage Determinations Website](http://www.dir.ca.gov/OPRL/DPreWageDetermination.htm) (http://www.dir.ca.gov/OPRL/DPreWageDetermination.htm). Holiday provisions for current or superseded determinations may be obtained by contacting the Office of the Director – Research Unit at (415) 703-4774.

Travel and/or subsistence payment:

In accordance with Labor Code Sections 1773.1 and 1773.9, contractors shall make travel and/or subsistence payments to each worker to execute the work. You may obtain the travel and/or subsistence provisions for the current determinations on the [Director's General Prevailing Wage Determinations Website](http://www.dir.ca.gov/OPRL/DPreWageDetermination.htm) (<http://www.dir.ca.gov/OPRL/DPreWageDetermination.htm>). Travel and/or subsistence requirements for current or superseded determinations may be obtained by contacting the Office of the Director – Research Unit at (415) 703-4774.

Classifications:

Group I

Batch Plant Laborer
Bottom Lander
Changehouseman
Dumpman
Outside Dumpman
Loading and Unloading Agitator Cars
Nipper
Pot Tender using mastic or other materials
Rollover Dumpman
Shotcrete Man (helper)
Subsurface Laborer (non-miner)
Swamper/Brakemen (Brakeman and Switchman on tunnel work)
Tool Man
Top Lander
Tunnel Materials Handling Man

Group II

Chemical Grout Jetman
Chucktender, Cabetender
Concrete crew-include Rodders and Spreaders
Grout Mixerman
Grout Pumpman
Operating of Troweling and/or Grouting Machines
Vibratorman, Jack Hammer Pneumatic Tools (except driller)

Group III

Blaster, Driller, Powderman
Bull Gang Mucker, Trackman
Cherry Pickerman
Grout Gunman
Jackleg Miner
Jumbo Man
Kemper and other Pneumatic Concrete Placer Operator

Micro-Tunneling, Micro-Tunneling Systems
Nozzleman
Powderman-Primer House
Primer Man
Sandblaster
Segment Erector
Steel Form Raiser and Setter
Timberman, Retimberman, wood or steel
Tunnel Concrete Finisher

Group IV

Shaft and Raise Work^d
Diamond Driller
HDPE Membrane Vapor Barrier Welder
Miner - Tunnel (hand or machine)

Group V

Welder, certified as required

^a For classifications within each group, see Page 2.

^b Includes an amount per hour worked for supplemental dues.

^c All work performed over 12 hours in a single work day shall be paid for at double time (2x).

^d The classification “Shaft and Raise Work” shall be applicable to all work from the entrance to the shaft or raise and including surge chambers. This classification shall apply to all work involving surge chambers up to ground level.

GENERAL PREVAILING WAGE DETERMINATION MADE BY
 THE DIRECTOR OF INDUSTRIAL RELATIONS PURSUANT TO CALIFORNIA LABOR CODE
 PART 7, CHAPTER 1, ARTICLE 2, SECTIONS 1770, 1773 AND 1773.1
 FOR COMMERCIAL BUILDING, HIGHWAY, HEAVY CONSTRUCTION AND DREDGING PROJECTS

CRAFT: TUNNEL (OPERATING ENGINEER) #

Determination:

SC-23-63-2-2023-2C

Issue Date:

August 22, 2023

Expiration date of determination:

June 30, 2024** The rate to be paid for work performed after this date has been determined. If work will extend past this date, the new rate must be paid and should be incorporated in contracts entered into now. Contact the Office of the Director - Research Unit for specific rates at (415) 703-4774.

Localities:

All localities within Imperial, Inyo, Kern, Los Angeles, Mono, Orange, Riverside, San Bernardino, San Luis Obispo, Santa Barbara and Ventura Counties.

Wages and total hourly rates (including employer payments):

Classification ^a (Journeyman)	Basic Hourly Rate	Hours	Total Hourly Rate	Daily Overtime Hourly Rate ^b (1½ x)	Saturday Overtime Hourly Rate ^c (1½ x)	Sunday/Holiday Overtime Hourly Rate (2 x)
Group 1	\$57.75	8	\$90.56	\$119.435	\$119.435	\$148.310
Group 2	\$58.53	8	\$91.34	\$120.605	\$120.605	\$149.870
Group 3	\$58.82	8	\$91.63	\$121.040	\$121.040	\$150.450
Group 4	\$58.96	8	\$91.77	\$121.250	\$121.250	\$150.730
Group 5	\$59.18	8	\$91.99	\$121.580	\$121.580	\$151.170
Group 6	\$59.29	8	\$92.10	\$121.745	\$121.745	\$151.390
Group 7	\$59.41	8	\$92.22	\$121.925	\$121.925	\$151.630
Group 8	\$60.76	8	\$93.57	\$123.950	\$123.950	\$154.330
Group 9	\$59.71	8	\$92.52	\$122.375	\$122.375	\$152.230

Employer Payments:

Type of Fund	Amount per Hour
Health and Welfare	\$12.85
Pension ^d	\$14.65
Vacation and Holiday ^e	\$3.85
Training	\$1.05
Other	\$0.41

GENERAL PREVAILING WAGE DETERMINATION MADE BY
THE DIRECTOR OF INDUSTRIAL RELATIONS PURSUANT TO CALIFORNIA LABOR CODE
PART 7, CHAPTER 1, ARTICLE 2, SECTIONS 1770, 1773 AND 1773.1
FOR COMMERCIAL BUILDING, HIGHWAY, HEAVY CONSTRUCTION AND DREDGING PROJECTS

CRAFT: TUNNEL (OPERATING ENGINEER) (MULTI-SHIFT) #

Determination:

SC-23-63-2-2023-2C

Issue Date:

August 22, 2023

Expiration date of determination:

June 30, 2024** The rate to be paid for work performed after this date has been determined. If work will extend past this date, the new rate must be paid and should be incorporated in contracts entered into now. Contact the Office of the Director - Research Unit for specific rates at (415) 703-4774.

Localities:

All localities within Imperial, Inyo, Kern, Los Angeles, Mono, Orange, Riverside, San Bernardino, San Luis Obispo, Santa Barbara and Ventura Counties.

Wages and total hourly rates (including employer payments):

Classification ^a (Journeyman)	Basic Hourly Rate	Hours	Total Hourly Rate	Daily Overtime Hourly Rate ^b (1½ x)	Saturday Overtime Hourly Rate ^c (1½ x)	Sunday/Holiday Overtime Hourly Rate (2 x)
Group 1	\$57.75	7.5	\$90.56	\$119.435	\$119.435	\$148.310
Group 2	\$58.53	7.5	\$91.34	\$120.605	\$120.605	\$149.870
Group 3	\$58.82	7.5	\$91.63	\$121.040	\$121.040	\$150.450
Group 4	\$58.96	7.5	\$91.77	\$121.250	\$121.250	\$150.730
Group 5	\$59.18	7.5	\$91.99	\$121.580	\$121.580	\$151.170
Group 6	\$59.29	7.5	\$92.10	\$121.745	\$121.745	\$151.390
Group 7	\$59.41	7.5	\$92.22	\$121.925	\$121.925	\$151.630
Group 8	\$60.76	7.5	\$93.57	\$123.950	\$123.950	\$154.330
Group 9	\$59.71	7.5	\$92.52	\$122.375	\$122.375	\$152.230

Employer Payments:

Type of Fund	Amount per Hour
Health and Welfare	\$12.85
Pension ^d	\$14.65
Vacation and Holiday ^e	\$3.85
Training	\$1.05
Other	\$0.41

Recognized holidays:

Holidays upon which the general prevailing hourly wage rate for Holiday work shall be paid, shall be all holidays in the collective bargaining agreement, applicable to the particular craft, classification, or type of worker employed on the project, which is on file with the Director of Industrial Relations. If the prevailing rate is not based on a collectively bargained rate, the holidays upon which the prevailing rate shall be paid shall be as provided in Section 6700 of the Government Code. You may obtain the holiday provisions for the current determinations on the [Director's General Prevailing Wage Determinations Website](http://www.dir.ca.gov/OPRL/DPreWageDetermination.htm) (<http://www.dir.ca.gov/OPRL/DPreWageDetermination.htm>). Holiday provisions for current or superseded determinations may be obtained by contacting the Office of the Director – Research Unit at (415) 703-4774.

Travel and/or subsistence payment:

In accordance with Labor Code Sections 1773.1 and 1773.9, contractors shall make travel and/or subsistence payments to each worker to execute the work. You may obtain the travel and/or subsistence provisions for the current determinations on the [Director's General Prevailing Wage Determinations Website](http://www.dir.ca.gov/OPRL/DPreWageDetermination.htm) (<http://www.dir.ca.gov/OPRL/DPreWageDetermination.htm>). Travel and/or subsistence requirements for current or superseded determinations may be obtained by contacting the Office of the Director – Research Unit at (415) 703-4774.

Classifications:

Group 1

Heavy Duty Repairman Helper

Group 2

Skiploader (wheel type up to ¾ yd. without attachment)

Group 3

Chainman
Power-Driver Jumbo Form Setter Operator

Group 4

Dinkey Locomotive or Motorman (up to and including 10 tons)
Rodman

Group 5

Bit Sharpener
Equipment Greaser (Grease Truck)
Instrumentman
Slip Form Pump Operator (power driven hydraulic lifting device for concrete forms)
Tugger Hoist Operator (1 drum)
Tunnel Locomotive Operator (over 10 and up to and including 30 tons)
Welder-General

Group 6

Backhoe Operator (up and including ¾ yd.) Small Ford, Case or similar types
Drill Doctor
Grouting Machine Operator
Heading Shield Operator
Heavy Duty Repairman
Jumbo Pipe Carrier
Loader Operator (Athey, Euclid, Sierra and similar types)
Mucking Machine Operator (1/4 yd rubber tired, rail or track type)
Pneumatic Concrete Placing Machine Operator (Hackley-Presswell or similar type)
Pneumatic Heading Shield (Tunnel)
Pumpcrete Gun Operator
Tractor Compressor Drill Combination Operator
Tugger Hoist Operator (2 drum)
Tunnel Locomotive Operator (over 30 tons)

Group 7

Heavy Duty Repairman-Welder Combination

Group 8

Party Chief

Group 9

Tunnel Mole Boring Machine Operator

MISCELLANEOUS PROVISIONS:

1. Operators on hoists with three drums shall receive fifty cents (50¢) per hour additional pay to the regular rate of pay. The additional pay shall be added to the regular rate and become the base rate for the entire shift.
2. All heavy duty repairman and heavy duty combination shall receive one dollar (\$1.00) per hour tool allowance in addition to their regular rate of pay and this shall become their base rate of pay.
3. Employees required to suit up and work in a hazardous material environment, shall receive Two Dollars (\$2.00) per hour in addition to their regular rate of pay, and that rate shall become the basic hourly rate of pay.

Indicates an apprenticeable craft. The current apprentice wage rates are available on the [Prevailing Wage Apprentice Determinations Website](http://www.dir.ca.gov/OPRL/PWAppWage/PWAppWageStart.asp) (<http://www.dir.ca.gov/OPRL/PWAppWage/PWAppWageStart.asp>).

^a For classifications within each group, see Page 3.

^b Rate applies to the first 4 overtime hours. All other daily overtime is paid at the Sunday rate.

^c Rate applies to the first 12 hours worked. All other time is paid at the Sunday rate.

^d Includes an amount for Annuity.

^e Includes an amount withheld for supplemental dues.

NOT FOR BID

SECTION 8

PROSECUTION AND PROGRESS

8-1.08–8-1.09 RESERVED

8-1.10 LIQUIDATED DAMAGES

8-1.10A General

The Department specifies liquidated damages (Pub Cont Code § 10226). Liquidated damages, if any, accrue starting on the 1st day after the expiration of the working days through the day of Contract acceptance except as specified in sections 8-1.10B and 8-1.10C.

The Department withholds liquidated damages before the accrual date if the anticipated liquidated damages may exceed the value of the remaining work.

Liquidated damages for all work except plant establishment or permanent erosion control establishment are as shown in the following table:

Liquidated Damages		Liquidated damages per day
Total bid		
From over	To	
\$0	\$60,000	\$1,400
\$60,000	\$200,000	\$2,900
\$200,000	\$500,000	\$3,200
\$500,000	\$1,000,000	\$3,500
\$1,000,000	\$2,000,000	\$4,000
\$2,000,000	\$5,000,000	\$4,800
\$5,000,000	\$10,000,000	\$6,800
\$10,000,000	\$20,000,000	\$10,000
\$20,000,000	\$50,000,000	\$13,500
\$50,000,000	\$100,000,000	\$19,200
\$100,000,000	\$250,000,000	\$25,300

If all work except plant establishment or permanent erosion control establishment is complete and the total number of working days have expired, liquidated damages are \$950 per day.

8-1.10B Failure to Complete Work Parts within Specified Times

The Department may deduct specified damages from payments for each day needed to complete a work part in excess of the time specified for completing the work part.

Damages for untimely completion of work parts may not be equal to the daily amount specified as liquidated damages for the project as a whole, but the Department does not simultaneously assess damages for untimely completion of work parts and for the whole work.

Damages accrue starting the 1st day after a work part exceeds the specified time through the day the specified work part is complete.

8-1.10C Failure to Complete Work Parts by Specified Dates

The Department may deduct specified damages from payments for each day needed to complete a work part in excess of the specified completion date for the work part.

Damages for untimely completion of a work part may not be equal to the daily amount specified as liquidated damages for the project as a whole, but the Department does not simultaneously assess damages for untimely completion of a work part and the whole work.

Damages accrue starting the 1st day after an unmet completion date through the day the work part is complete.

8-1.10D Reserved

8-1.11–8-1.12 RESERVED

8-1.13 CONTRACTOR'S CONTROL TERMINATION

The Department may terminate your control of the work for failure to do any of the following (Pub Cont Code § 10253):

Bidder: _____

PROPOSAL

**TO THE BOARD OF SUPERVISORS
OF SAN BERNARDINO COUNTY
STATE OF CALIFORNIA**

For Construction On

**GUARDRAIL REPLACEMENT PROJECT AT DEVORE AREA
Various**

**LENGTH: Various
WORK ORDER: TX1799
AREA: Devore
ROAD NO.: 199950 060**

NOTICE: BIDDERS MUST OBTAIN BIDDING DOCUMENTS AND PREPARE THEIR BIDS ON FORMS OBTAINED DIRECTLY FROM THE SAN BERNARDINO COUNTY DEPARTMENT OF PUBLIC WORKS OR FROM THE SAN BERNARDINO COUNTY ELECTRONIC PROCUREMENT NETWORK (ePRO) <https://epro.sbcounty.gov/bsol/>. BIDS PREPARED ON FORMS OBTAINED FROM OTHER SOURCES WILL BE DEEMED NON-RESPONSIVE. BIDDERS MUST BE LISTED ON THE OFFICIAL PLAN HOLDERS LIST AT THE TIME BIDS ARE PUBLICLY OPENED. BIDS RECEIVED FROM BIDDERS WHO ARE NOT LISTED ON THE OFFICIAL PLAN HOLDERS LIST WILL NOT BE ACCEPTED.

The undersigned, as bidder, declares that the only persons or parties interested in this proposal as principals are those named herein, that this proposal is made without collusion with any other person, firm, or corporation; that bidder has carefully examined the location of the proposed work, the proposed form of contract, and the plans and specifications therein referred to; and bidder proposes and agrees if this proposal is accepted, that bidder will contract with the San Bernardino County, in the form of the copy of the contract to provide all necessary machinery, tools, apparatus and other means of construction, and to do all work and furnish all the materials specified in the contract, in the manner and in the time therein prescribed, and according to the requirements of the Engineer as therein set forth, and that bidder will take in full payment therefore the following prices, to with:

PROPOSAL CHECKLIST AND ASSEMBLY SEQUENCE

IMPORTANT

Failure to Properly Complete Bid Package May Result in Rejection of Bid

1

Proposal – Assemble all pages in same numbering sequence as original.

- Replacement Bid Sheets from Addendum are substituted in sequence, if applicable.
- Unit Prices are entered for all bid items (or Alternate bid items).
- Corrections or changes to the bid document are initialed.
- Subcontractors, if any, are listed
- Public Contract Code Section 10285.1 Statement is executed
- Public Contract Code Section 10162 Questionnaire is completed
- Noncollusion Declaration is executed and submitted with bid.
- Bidder Information is completed and correct.
- Proposal is complete and signed by authorized company representative.

2

Addendums, if any, are acknowledged. (Normally sent by facsimile and mail)

- "Bidder's Certification" (Just the Certification page) are executed and attached.

3

Bidder's Security.

- 10% of Bid Amount in Cash, Cashier's Check, Certified Check or Bidder's Bond.
- If Bidder's Bond, surety signature is notarized.
- If Bidder's Bond, surety power of attorney is attached.

4

ePRO.

- Registered as a Vendor in the ePro System prior to date and time to receive bid.
- Bid submitted through ePro, the original Bid Security must be submitted in a separate sealed envelope labeled "Bid Bond" with the title of the work and name of bidder marked on outside of envelope to the Department of Public Works, Front Reception. Must be received on or before the time set for the opening of bids.
- For bid submission through ePro, scan and attach to your quote the Fully Executed Proposal Documents (pages P-1 thru P-20).
- Sign and date the "Acknowledgement ePro Process".
- For bid submission through ePro, scan and attach to your quote the fully executed Certification page for ALL Addendums.

5

REGISTERED WITH THE DEPARTMENT OF INDUSTRIAL RELATIONS (DIR) (SENATE BILL 854) AND CALIFORNIA AIR RESOURCES BOARD (CARB IN-USE OFF-ROAD DIESEL-FUEL

Bidder: _____

FLEETS REGULATION COMPLIANCE CERTIFICATION.

DIR Registration Number and CARB Certificate of Compliance Number identified for Bidder and all subcontractors.

ACKNOWLEDGEMENT OF ePro PROCESS

Bidder is registered as a vendor with San Bernardino County Electronic Procurement Network (ePro) prior to date and time to receive bids.

Bidder has logged-in to the ePro system with the correct commodity code and downloaded the official bid documents through the ePro system prior to the date and time to receive bids.

If bidder submits a proposal via ePro, the proposal was uploaded in ePro while logged-in to the ePro system under the bidder's account.

Bidder confirmed it is listed on the "Official Plan Holders List" by checking on ePro or by calling the County representative at (909) 387-7920 to confirm bidder is on the "Official Plan Holders List" prior to the date and time bids are publicly opened.

Bidder to submit in person bidder's security and/or proposal in a sealed envelope prior to the proposal opening date and time.

**For system-related issues and technical assistance with ePro, please contact vendor support at ePro.Vendors@buyspeed.com or at (855) 800-5046. For questions involving ePro, such as user accounts, commodity codes, and/or status or placement on the Official Plan Holders List, please contact the Purchasing Department at (909) 387-2060.*

BIDDER'S CERTIFICATION:

By my signature hereunder, I acknowledge I fully understand the above requirements, which I have considered in my preparation of the proposal. I also understand that failure to comply with the above requirements will result in the rejection of bid.

Bidder's Signature

Date

Bidder: _____

Project: **D022 Guardrail Replacement
at Various Locations**

W.O.#: **TX1799**

Limits: **Devore Area**

Item No.	Approx. Quant.	Meas. Unit	Item Description	Unit Price	Total
1	75,000	F.A.	Supplemental Work at Force Account (Unforeseen Utility Conflict and Subgrade Stabilization)	\$ 1.00	\$ 75,000.00
2	1	L.S.	Water Pollution Control Program	\$	\$
3	1	L.S.	Mobilization	\$	\$
4	1	L.S.	Traffic Control System	\$	\$
5	4	EA.	Portable Changeable Message Sign	\$	\$
6	2,186	L.F.	Remove Guard Railing	\$	\$
7	1,304	L.F.	Remove Asphalt Concrete Dike	\$	\$
8	332	L.F.	Remove Concrete Curb	\$	\$
9	60	L.F.	Remove Concrete Barrier (Type K)	\$	\$
10	279	L.F.	Remove Barrier Railing	\$	\$
11	1	L.S.	Clearing and Grubbing	\$	\$
12	1	L.S.	Finishing Roadway	\$	\$
13	844	L.F.	Place Asphalt Concrete Dike (Type C)	\$	\$
14	1,142	L.F.	Place Asphalt Concrete Dike (Type F)	\$	\$
15	1,578	S.Y.	Minor Concrete (Vegetation Control)	\$	\$
16	125	EA.	Guard Railing Delineator (Type E)	\$	\$
17	24	EA.	Object Marker - Type P(CA)(OM-3L or OM-3R)	\$	\$
18	3,438	L.F.	Midwest Guard Railing (Steel Post)	\$	\$
19	250	L.F.	Midwest Guard Railing (Special)	\$	\$
20	20	L.F.	Concrete Barrier Transition	\$	\$
21	80	L.F.	Barricade	\$	\$
22	7	EA.	Transition Railing (Type WB-31)	\$	\$
23	1	E.A.	End Anchor Assembly (Type SFT)	\$	\$
24	24	E.A.	In-Line Terminal System	\$	\$
25	5,656	L.F.	Paint 6" wide Traffic Stripe (2-Coat)	\$	\$
26	1	L.S.	Fire Plan	\$	\$

PROJECT TOTAL: \$

Bids are to be submitted for the entire work. The amount of the bid for comparison purposes will be the total of all items.

The bidder shall set forth for each unit basis item of work a unit price and a total for the item, and for each lump sum item a total for the item, all in clearly legible figures in the respective spaces provided for this purpose. In the case of unit basis items, the amount set forth under the "Total" column shall be the extension of the unit price bid on the basis of the estimated quantity for the item.

In case of discrepancy between the unit price and the total set forth for a unit basis item, the unit price shall prevail, however, if the amount set forth as a unit price is ambiguous, unintelligible or uncertain for any cause, or is omitted, then the amount set forth in the "Total" column for the item shall prevail and shall be divided by the estimated quantity for the item and the price thus obtained, rounded to the next lower penny, shall be the unit price.

If this proposal shall be accepted, the contract shall be signed by the successful bidder and returned **within 10 days**, and the contract bonds, copy of insurance policies, and Certificates of Insurance, with documents to verify any self-insurance coverage shall be provided **within 10 days**, not including Saturdays, Sundays and legal holidays, after the bidder has received the contract for execution. Should the undersigned fail to contract as aforesaid, the Board of Supervisors may, at its option, determine that the bidder has abandoned the contract, and, thereupon, this proposal and the acceptance thereof shall be null and void, and the forfeiture of such security accompanying this proposal shall operate and the same may be the property of the San Bernardino County.

NOT FOR BIDDING

NOTE: THIS FORM MUST BE COMPLETED, SIGNED AND RETURNED WITH THE PROPOSAL

BIDDER _____

The bidder shall complete the following information as required by the Subletting and Subcontracting Fair Practices Act, Public Contract Code section 4100 et seq.

Note: Subcontractors must be licensed and registered with the DIR (with limited exceptions from this requirement for bid purposes only under Labor Code section 1771.1(a)) at the time of the bid opening.

Information marked with ** is required. (Make additional copies of this form if needed)

SUBCONTRACTORS LIST

Name: ** _____ Fed. ID: _____ Item(s) #: ** _____

Business Location: ** _____ % (s): _____

Telephone: () _____ Amount: \$ _____

License #: ** _____ Description of Work: ** _____

DIR Registration #: ** _____ CARB Certificate of Compliance No.: _____

Name: ** _____ Fed. ID: _____ Item(s) #: ** _____

Business Location: ** _____ % (s): _____

Telephone: () _____ Amount: \$ _____

License #: ** _____ Description of Work: ** _____

DIR Registration #: ** _____ CARB Certificate of Compliance No.: _____

Name: ** _____ Fed. ID: _____ Item(s) #: ** _____

Business Location: ** _____ % (s): _____

Telephone: () _____ Amount: \$ _____

License #: ** _____ Description of Work: ** _____

DIR Registration #: ** _____ CARB Certificate of Compliance No.: _____

Name: ** _____ Fed. ID: _____ Item(s) #: ** _____

Business Location: ** _____ % (s): _____

Telephone: () _____ Amount: \$ _____

License #: ** _____ Description of Work: ** _____

DIR Registration #: ** _____ CARB Certificate of Compliance No.: _____

NOTE: THIS FORM MUST BE COMPLETED, SIGNED AND RETURNED WITH THE PROPOSAL

PUBLIC CONTRACT CODE SECTION 10232 STATEMENT

In accordance with Public Contract Code section 10232, the Contractor hereby states, under penalty of perjury, that no more than one final unappealable finding of contempt of court by a federal court has been issued against the Contractor within the immediately preceding two year period because of the Contractor's failure to comply with an order of a federal court which orders the Contractor to comply with an order of the National Labor Relations Board.

PUBLIC CONTRACT CODE SECTION 10285.1 STATEMENT

In accordance with Public Contract Code section 10285.1, the bidder hereby declares under penalty of perjury that the bidder

has Check One has not

been convicted within the preceding three years of any offenses referred to in that section, including any charge of fraud, bribery, collusion, conspiracy, or any other act in violation of any state or federal antitrust law in connection with the bidding upon, award of, or performance of, any public works contract, as defined in Public Contract Code section 1101, with any public entity, as defined in Public Contract Code section 1100, including the Regents of the University of California or the Trustees of the California State University. The term "bidder" is understood to include any partner, member, officer, director, responsible managing officer, or responsible managing employee thereof, as referred to in Section 10285.1.

Note: The bidder must place a check mark after "has" or "has not" in one of the blank spaces provided.

The above Statements are part of the Proposal. Signing this Proposal on the signature portion thereof shall also constitute signature of these Statements.

Bidders are cautioned that making a false certification may subject the certifier to criminal prosecution.

PUBLIC CONTRACT CODE
SECTIONS 9204, 20104, 20104.2, 20104.4, 20104.6, AND 20104.50
RESOLUTION OF CONSTRUCTION CLAIMS AND PROMPT PAYMENT

9204

(a) The Legislature finds and declares that it is in the best interests of the state and its citizens to ensure that all construction business performed on a public works project in the state that is complete and not in dispute is paid in full and in a timely manner.

(b) Notwithstanding any other law, including, but not limited to, Article 7.1 (commencing with Section 10240) of Chapter 1 of Part 2, Chapter 10 (commencing with Section 19100) of Part 2, and Article 1.5 (commencing with Section 20104) of Chapter 1 of Part 3, this section shall apply to any claim by a contractor in connection with a public works project.

(c) For purposes of this section:

(1) "Claim" means a separate demand by a contractor sent by registered mail or certified mail with return receipt requested, for one or more of the following:

(A) A time extension, including, without limitation, for relief from damages or penalties for delay assessed by a public entity under a contract for a public works project.

(B) Payment by the public entity of money or damages arising from work done by, or on behalf of, the contractor pursuant to the contract for a public works project and payment for which is not otherwise expressly provided or to which the claimant is not otherwise entitled.

(C) Payment of an amount that is disputed by the public entity.

(2) "Contractor" means any type of contractor within the meaning of Chapter 9 (commencing with Section 7000) of Division 3 of the Business and Professions Code who has entered into a direct contract with a public entity for a public works project.

(3) (A) "Public entity" means, without limitation, except as provided in subparagraph (B), a state agency, department, office, division, bureau, board, or commission, the California State University, the University of California, a city, including a charter city, county, including a charter county, city and county, including a charter city and county, district, special district, public authority, political subdivision, public corporation, or nonprofit transit corporation wholly owned by a public agency and formed to carry out the purposes of the public agency.

(B) "Public entity" shall not include the following:

(i) The Department of Water Resources as to any project under the jurisdiction of that department.

(ii) The Department of Transportation as to any project under the jurisdiction of that department.

(iii) The Department of Parks and Recreation as to any project under the jurisdiction of that department.

(iv) The Department of Corrections and Rehabilitation with respect to any project under its jurisdiction pursuant to Chapter 11 (commencing with Section 7000) of Title 7 of Part 3 of the Penal Code.

(v) The Military Department as to any project under the jurisdiction of that department.

(vi) The Department of General Services as to all other projects.

(vii) The High-Speed Rail Authority.

(4) "Public works project" means the erection, construction, alteration, repair, or improvement of any public structure, building, road, or other public improvement of any kind.

(5) "Subcontractor" means any type of contractor within the meaning of Chapter 9 (commencing with Section 7000) of Division 3 of the Business and Professions Code who either is in direct contract with a contractor or is a lower tier subcontractor.

(d) (1) (A) Upon receipt of a claim pursuant to this section, the public entity to which the claim applies shall conduct a reasonable review of the claim and, within a period not to exceed 45 days, shall provide the claimant a written statement identifying what portion of the claim is disputed and what portion is undisputed. Upon receipt of a claim, a public entity and a contractor may, by mutual agreement, extend the time period provided in this subdivision.

(B) The claimant shall furnish reasonable documentation to support the claim.

(C) If the public entity needs approval from its governing body to provide the claimant a written statement identifying the disputed portion and the undisputed portion of the claim, and the governing body does not meet within the 45 days or within the mutually agreed to extension of time following receipt of a claim sent by registered mail or certified mail, return receipt requested, the public entity shall have up to three days following the next duly publicly noticed meeting of the governing body after the 45-day period, or extension, expires to provide the claimant a written statement identifying the disputed portion and the undisputed portion.

(D) Any payment due on an undisputed portion of the claim shall be processed and made within 60 days after the public entity issues its written statement. If the public entity fails to issue a written statement, paragraph (3) shall apply.

(2) (A) If the claimant disputes the public entity's written response, or if the public entity fails to respond to a claim issued pursuant to this section within the time prescribed, the claimant may demand in writing an informal conference to meet and confer for settlement of the issues in dispute. Upon receipt of a demand in writing sent by registered mail or certified mail, return receipt requested, the public entity shall schedule a meet and confer conference within 30 days for settlement of the dispute.

(B) Within 10 business days following the conclusion of the meet and confer conference, if the claim or any portion of the claim remains in dispute, the public entity shall provide the claimant a written statement identifying the portion of the claim that remains in dispute and the portion that is undisputed. Any payment due on an undisputed portion of the claim shall be processed and made within 60 days after the public entity issues its written statement. Any disputed portion of the claim, as identified by the contractor in writing, shall be submitted to nonbinding mediation, with the public entity and the claimant sharing the associated costs equally. The public entity and claimant shall mutually agree to a mediator within 10 business days after the

disputed portion of the claim has been identified in writing. If the parties cannot agree upon a mediator, each party shall select a mediator and those mediators shall select a qualified neutral third party to mediate with regard to the disputed portion of the claim. Each party shall bear the fees and costs charged by its respective mediator in connection with the selection of the neutral mediator. If mediation is unsuccessful, the parts of the claim remaining in dispute shall be subject to applicable procedures outside this section.

(C) For purposes of this section, mediation includes any nonbinding process, including, but not limited to, neutral evaluation or a dispute review board, in which an independent third party or board assists the parties in dispute resolution through negotiation or by issuance of an evaluation. Any mediation utilized shall conform to the timeframes in this section.

(D) Unless otherwise agreed to by the public entity and the contractor in writing, the mediation conducted pursuant to this section shall excuse any further obligation under Section 20104.4 to mediate after litigation has been commenced.

(E) This section does not preclude a public entity from requiring arbitration of disputes under private arbitration or the Public Works Contract Arbitration Program, if mediation under this section does not resolve the parties' dispute.

(3) Failure by the public entity to respond to a claim from a contractor within the time periods described in this subdivision or to otherwise meet the time requirements of this section shall result in the claim being deemed rejected in its entirety. A claim that is denied by reason of the public entity's failure to have responded to a claim, or its failure to otherwise meet the time requirements of this section, shall not constitute an adverse finding with regard to the merits of the claim or the responsibility or qualifications of the claimant.

(4) Amounts not paid in a timely manner as required by this section shall bear interest at 7 percent per annum.

(5) If a subcontractor or a lower tier subcontractor lacks legal standing to assert a claim against a public entity because privity of contract does not exist, the contractor may present to the public entity a claim on behalf of a subcontractor or lower tier subcontractor. A subcontractor may request in writing, either on his or her own behalf or on behalf of a lower tier subcontractor, that the contractor present a claim for work which was performed by the subcontractor or by a lower tier subcontractor on behalf of the subcontractor. The subcontractor requesting that the claim be presented to the public entity shall furnish reasonable documentation to support the claim. Within 45 days of receipt of this written request, the contractor shall notify the subcontractor in writing as to whether the contractor presented the claim to the public entity and, if the original contractor did not present the claim, provide the subcontractor with a statement of the reasons for not having done so.

(e) The text of this section or a summary of it shall be set forth in the plans or specifications for any public works project that may give rise to a claim under this section.

(f) A waiver of the rights granted by this section is void and contrary to public policy, provided, however, that (1) upon receipt of a claim, the parties may mutually agree to waive, in writing, mediation and proceed directly to the commencement of a civil action or binding arbitration, as applicable; and (2) a public entity may prescribe reasonable change order, claim, and dispute resolution procedures and requirements in addition to the provisions of this section, so long as the contractual provisions do not conflict with or otherwise impair the timeframes and procedures set forth in this section.

(g) This section applies to contracts entered into on or after January 1, 2017.

(h) Nothing in this section shall impose liability upon a public entity that makes loans or grants available through a competitive application process, for the failure of an awardee to meet its contractual obligations.

(i) This section shall remain in effect only until January 1, 2020, and as of that date is repealed, unless a later enacted statute, that is enacted before January 1, 2020, deletes or extends that date.

20104.

(a)(1) This article applies to all public works claims of three hundred seventy-five thousand dollars (\$375,000) or less which arise between a contractor and a local agency.

(2) This article shall not apply to any claims resulting from a contract between a contractor and a public agency when the public agency has elected to resolve any disputes pursuant to Article 7.1 (commencing with Section 10240) of Chapter 1 of Part 2.

(b)(1) "Public work" means "public works contract" as defined in Section 1101 but does not include any work or improvement contracted for by the state or the Regents of the University of California.

(2) "Claim" means a separate demand by the contractor for (A) a time extension, (B) payment of money or damages arising from work done by, or on behalf of, the contractor pursuant to the contract for a public work and payment of which is not otherwise expressly provided for or the claimant is not otherwise entitled to, or (C) an amount the payment of which is disputed by the local agency.

(c) The provisions of this article or a summary thereof shall be set forth in the plans or specifications for any work which may give rise to a claim under this article.

(d) This article applies only to contracts entered into on or after January 1, 1991.

20104.2 For any claim subject to this article, the following requirements apply:

(a) The claim shall be in writing and include the documents necessary to substantiate the claim. Claims must be filed on or before the date of final payment. Nothing in this subdivision is intended to extend the time limit or supersede notice requirements otherwise provided by contract for the filing of claims.

(b)(1) For claims of less than fifty thousand dollars (\$50,000), the local agency shall respond in writing to any written claim within 45 days of receipt of the claim, or may request, in writing, within 30 days of receipt of the claim, any additional documentation supporting the claim or relating to defenses to the claim the local agency may have against the claimant.

(2) If additional information is thereafter required, it shall be requested and provided pursuant to this subdivision, upon mutual agreement of the local agency and the claimant.

(3) The local agency's written response to the claim, as further documented, shall be submitted to the claimant within 15 days after receipt of the further documentation or within a period of time no greater than that taken by the claimant in producing the additional information, whichever is greater.

(c)(1) For claims of over fifty thousand dollars (\$50,000) and less than or equal to three hundred seventy-five thousand dollars (\$375,000), the local agency shall respond in writing to all written claims within 60 days of receipt of the claim, or may request, in writing, within 30 days of receipt of the claim, any additional documentation supporting the claim or relating to defenses to the claim the local agency may have against the claimant.

(2) If additional information is thereafter required, it shall be requested and provided pursuant to this subdivision, upon mutual agreement of the local agency and the claimant.

(3) The local agency's written response to the claim, as further documented, shall be submitted to the claimant within 30 days after receipt of the further documentation, or within a period of time no greater than that taken by the claimant in producing the additional information or requested documentation, whichever is greater.

(d) If the claimant disputes the local agency's written response, or the local agency fails to respond within the time prescribed, the claimant may so notify the local agency, in writing, either within 15 days of receipt of the local agency's response or within 15 days of the local agency's failure to respond within the time prescribed, respectively, and demand an informal conference to meet and confer for settlement of the issues in dispute. Upon a demand, the local agency shall schedule a meet and confer conference within 30 days for settlement of the dispute.

(e) Following the meet and confer conference, if the claim or any portion remains in dispute, the claimant may file a claim as provided in Chapter 1 (commencing with Section 900) and Chapter 2 (commencing with Section 910) of Part 3 of Division 3.6 of Title 1 of the Government Code. For purposes of those provisions, the running of the period of time within which a claim must be filed shall be tolled from the time the claimant submits his or her written claim pursuant to subdivision (a) until the time that claim is denied as a result of the meet and confer process, including any period of time utilized by the meet and confer process.

(f) This article does not apply to tort claims and nothing in this article is intended nor shall be construed to change the time periods for filing tort claims or actions specified by Chapter 1 (commencing with Section 900) and Chapter 2 (commencing with Section 910) of Part 3 of Division 3.6 of Title 1 of the Government Code.

20104.4 The following procedures are established for all civil actions filed to resolve claims subject to this article:

(a) Within 60 days, but no earlier than 30 days, following the filing or responsive pleadings, the court shall submit the matter to nonbinding mediation unless waived by mutual stipulation of both parties. The mediation process shall provide for the selection within 15 days by both parties of a disinterested third person as mediator, shall be commenced within 30 days of the submittal, and shall be concluded within 15 days from the commencement of the mediation unless a time requirement is extended upon a good cause showing to the court or by

stipulation of both parties. If the parties fail to select a mediator within the 15-day period, any party may petition the court to appoint the mediator.

(b)(1) If the matter remains in dispute, the case shall be submitted to judicial arbitration pursuant to Chapter 2.5 (commencing with Section 1141.10) of Title 3 of Part 3 of the Code of Civil Procedure, notwithstanding Section 1141.11 of that code. The Civil Discovery Act (Title 4 (commencing with Section 2016.10) of Part 4 of the Code of Civil Procedure) shall apply to any proceeding brought under this subdivision consistent with the rules pertaining to judicial arbitration.

(2) Notwithstanding any other provision of law, upon stipulation of the parties, arbitrators appointed for purposes of this article shall be experienced in construction law, and, upon stipulation of the parties, mediators and arbitrators shall be paid necessary and reasonable hourly rates of pay not to exceed their customary rate, and such fees and expenses shall be paid equally by the parties, except in the case of arbitration where the arbitrator, for good cause, determines a different division. In no event shall these fees or expenses be paid by state or county funds.

(3) In addition to Chapter 2.5 (commencing with Section 1141.10) of Title 3 of Part 3 of the Code of Civil Procedure, any party who after receiving an arbitration award requests a trial de novo but does not obtain a more favorable judgment shall, in addition to payment of costs and fees under that chapter, pay the attorney's fees of the other party arising out of the trial de novo.

(c) The court may, upon request by any party, order any witnesses to participate in the mediation or arbitration process.

20104.6

(a) No local agency shall fail to pay money as to any portion of a claim which is undisputed except as otherwise provided in the contract.

(b) In any suit filed under Section 20104.4, the local agency shall pay interest at the legal rate on any arbitration award or judgment. The interest shall begin to accrue on the date the suit is filed in a court of law.

ARTICLE 1.7

Modification, Performance, Payment

20104.50

(a) (1) It is the intent of the Legislature in enacting this section to require all local governments to pay their contractors on time so that these contractors can meet their own obligations. In requiring prompt payment by all local governments, the Legislature hereby finds and declares that the prompt payment of outstanding receipts is not merely a municipal affair, but is, instead, a matter of statewide concern.

(2) It is the intent of the Legislature in enacting this article to fully occupy the field of public policy relating to the prompt payment of local governments' outstanding receipts. The Legislature finds and declares that all government officials, including those in local government, must set a standard of prompt payment that any business in the private sector which may contract for services should look towards for guidance.

(b) Any local agency which fails to make any progress payment within 30 days after receipt of an undisputed and properly submitted payment request from a contractor on a construction contract shall pay interest to the contractor equivalent to the legal rate set forth in subdivision (a) of Section 685.010 of the Code of Civil Procedure.

(c) Upon receipt of a payment request, each local agency shall act in accordance with both of the following:

(1) Each payment request shall be reviewed by the local agency as soon as practicable after receipt for the purpose of determining that the payment request is a proper payment request.

(2) Any payment request determined not to be a proper payment request suitable for payment shall be returned to the contractor as soon as practicable, but not later than seven days, after receipt. A request returned pursuant to this paragraph shall be accompanied by a document setting forth in writing the reasons why the payment request is not proper.

(d) The number of days available to a local agency to make a payment without incurring interest pursuant to this section shall be reduced by the number of days by which a local agency exceeds the seven-day return requirement set forth in paragraph (2) of subdivision (c).

(e) For purposes of this article:

(1) A "local agency" includes, but is not limited to, a city, including a charter city, a county, and a city and county, and is any public entity subject to this part.

(2) A "progress payment" includes all payments due contractors, except that portion of the final payment designated by the contract as retention earnings.

(3) A payment request shall be considered properly executed if funds are available for payment of the payment request, and payment is not delayed due to an audit inquiry by the financial officer of the local agency.

(f) Each local agency shall require that this article, or a summary thereof, be set forth in the terms of any contract subject to this article.

NOTE: THIS FORM MUST BE COMPLETED, SIGNED AND RETURNED WITH THE PROPOSAL

**NONCOLLUSION DECLARATION
TO BE EXECUTED BY BIDDER AND SUBMITTED WITH BID**

(Public Contract Code section 7106)

The undersigned declares:

I am the _____ [title] of _____ [name of the bidder], the party making the foregoing bid.

The bid is not made in the interest of, or on behalf of, any undisclosed person, partnership, company, association, organization, or corporation. The bid is genuine and not collusive or sham. The bidder has not directly or indirectly induced or solicited any other bidder to put in a false or sham bid. The bidder has not directly or indirectly colluded, conspired, connived, or agreed with any bidder or anyone else to put in a sham bid, or to refrain from bidding. The bidder has not in any manner, directly or indirectly, sought by agreement, communication, or conference with anyone to fix the bid price of the bidder or any other bidder, or to fix any overhead, profit, or cost element of the bid price, or of that of any other bidder. All statements contained in the bid are true. The bidder has not, directly or indirectly, submitted his or her bid price or any breakdown thereof, or the contents thereof, or divulged information or data relative thereto, to any corporation, partnership, company, association, organization, bid depository, or to any member or agent thereof, to effectuate a collusive or sham bid, and has not paid, and will not pay, any person or entity for such purpose.

Any person executing this declaration on behalf of a bidder that is a corporation, partnership, joint venture, limited liability company, limited liability partnership, or any other entity, hereby represents that he or she has full power to execute, and does execute, this declaration on behalf of the bidder.

I declare under penalty of perjury under the laws of the State of California that the foregoing is true and correct and that this declaration is executed on

_____ [date], at _____ [city], _____ [state].

Print Name

Signature - REQUIRED

NOTE: The above Noncollusion Declaration is part of the Bid, and failure to include the Noncollusion Declaration with the Bid will result in the Bid being found nonresponsive.

Bidders are reminded that this declaration must be signed under penalty of perjury.

If the bid proposal is submitted through ePro the undersigned acknowledges that its electronic signature is legally binding.

**IRAN CONTRACTING ACT OF 2010
(Public Contract Code section 2200 et seq.)**

(Applicable only to Contracts of One Million Dollars (\$1,000,000) or More):

In accordance with Public Contract Code section 2204 (a), the bidder certifies that at the time the bid is submitted or the contract is renewed, that bidder is not identified on a list created pursuant to subdivision (b) of Public Contract Code section 2203 as a person engaging in investment activities in Iran described in subdivision (a) of Public Contract Code section 2202.5, or as a person described in subdivision (b) of Public Contract Code section 2202.5, as applicable. A state agency shall submit the certification information to the Department of General Services.

RUSSIAN SANCTION/EXECUTIVE ORDER N-6-22 (Applicable for all Contracts of five million dollars (\$5,000,000) or more utilizing State funding.): On March 4, 2022, Governor Gavin Newsom issued Executive Order N-6-22 (the EO) regarding Economic Sanctions against Russia and Russian entities and individuals. "Economic Sanctions" refers to sanctions imposed by the U.S. government in response to Russia's actions in Ukraine (<https://home.treasury.gov/policy-issues/financial-sanctions/sanctions-programs-and-country-information/ukraine-russia-related-sanctions>), as well as any sanctions imposed under state law (<https://www.dgs.ca.gov/OLS/Ukraine-Russia>). The EO directs state agencies and their contractors (including by agreement or receipt of a grant) to terminate contracts with, and to refrain from entering any new contracts with, individuals or entities that are determined to be a target of Economic Sanctions. Accordingly, should it be determined that Contractor is a target of Economic Sanctions or is conducting prohibited transactions with sanctioned individuals or entities, that shall be grounds for termination of this agreement. Contractor shall be provided advance written notice of such termination, allowing Contractor at least 30 calendar days to provide a written response. Termination shall be at the sole discretion of the County.

NOTE: The above Certification is part of the Proposal. Signing this Proposal on the signature portion thereof shall also constitute signature of this Certification.

Bidders are cautioned that making a false certification may subject bidder to civil penalties, termination of existing contract, and ineligibility to bid on a contract for a period of three (3) years in accordance with Public Contract Code section 2205.